

ProteCol™ MicroFlow Meter



Optimum and accurate flow rates

- Simple, accurate design based on proven SGE syringe technology
- Universal principle does not require calibration for different solvents
- Two versions cover the flow rate range for LC columns ranging from microbore to nanobore
 - Choose 0.2-10 $\mu\text{L}/\text{min}$ meter for columns 300 μm ID and below
 - Choose 2.5-100 $\mu\text{L}/\text{min}$ meter for columns 300 μm ID and above
- Essential tool for checking and establishing optimum flow rate
- Enables documentation of actual experimental conditions for notebooks or publication
- Valuable tool for troubleshooting when retention times fluctuate

The new ProteCol MicroFlow Meter is a fast, simple and reliable way to accurately measure flow rates in Capillary LC and for other low flow applications. The direct measurement of flow provides definitive confirmation of the actual flow rate through the column and is the perfect LC system companion whether pumps require flow splitters or deliver low flow directly.

Accurate, stable flow rates are the key to reproducible retention times, and using the optimum flow rate for a column is very important to achieving the best possible performance.

Whether conducting research or doing routine analysis, good lab practice requires documentation of flow rates for your records or for publication.

| ID (mm) | Typical Flow Rate Range ($\mu\text{L}/\text{min}$) |
|---------|--|
| 1 | 47 [30-70] |
| 0.5 | 12 [8-18] |
| 0.3 | 4.2 [3-6.4] |
| 0.15 | 1.1 [0.75-1.6] |
| 0.075 | 0.27 [0.2-.04] |

The ProteCol MicroFlow Meter is available in two configurations, optimized for flow rates in the range of 0.2 - 10µl/min and 2.5 - 100µl/min. Based on proven SGE syringe technology, the microflow meter is accurate and simple to use as follows:

1. Ensure that the stainless steel outlet tube is fully filled before opening the Air Inlet Valve ⑥. The hydrostatic pressure is needed to avoid liquid rising into the air inlet valve.
2. Open and close the Air Inlet Valve ⑥ within one second to introduce a bubble into the flow chamber. At very low flows (<0.5µL/min), it could take up to 30 seconds for the air bubble to reach the top of the graduation on the tube.
3. Time the bubble's progress between the graduated marks printed on the Graduated Flow Chamber ⑦ with a stop watch.

Calculate the flow rate using the formula:

$$\text{Flowrate } (\mu\text{L}/\text{min}) = \frac{\text{swept volume } (\mu\text{L})}{\text{time (sec)}} [60]$$

Parts List:

- ProteCol MicroFlow Meter
- PEEK Ferrule 1/16" ID pkt 5
- Adapter tube 1/16" to 1/32"
- Adapter tube 1/16" to fused silica
- Power supply 12V (uses 110/240V)
- Adhesive strip
- Stainless Steel Outlet Tube 1/16" x 1/32 x 140mm

- ① Double sided tape
- ② Capillary LC tubing
- ③ Capillary to 1/16" adapter or 1/32" to 1/16" adapter
- ④ Nut
- ⑤ Double sided ferrule
- ⑥ Air Inlet Valve
- ⑦ Graduated Flow Chamber
- ⑧ Stainless Steel Outlet Tubing
- ⑨ Nut
- ⑩ Double sided ferrule

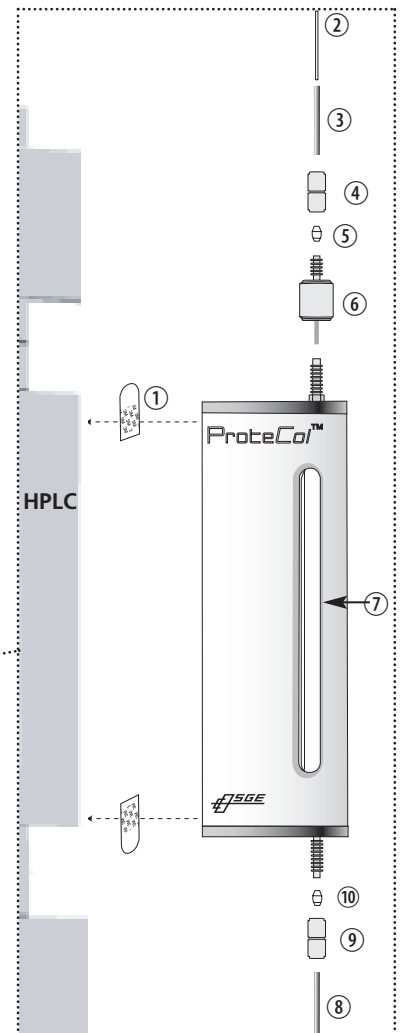
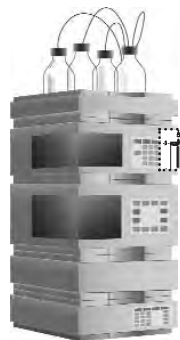

For a full listing of all ProteCol products, specifications and part numbers, please see the ProteCol Ordering Information data sheet.

To talk with a technical expert, email support@sge.com.

View the ProteCol MicroFlow Meter specifications and purchase online.

SGE International Pty. Ltd.
 Toll Free: 1800 800 167
 Tel: +61 (0) 3 9837 4200
 Fax: +61 (0) 3 9874 5672
 email: support@sge.com

SGE Incorporated (USA)
 Toll Free: 800 945 6154
 Tel: +1 512 837 7190
 Fax: +1 512 836 9159
 email: usa@sge.com

SGE China Service Centre
 Tel: +86 (10) 6588 8666
 Fax: +86 (10) 6588 6577

SGE Europe Ltd. (UK)
 Tel: +44 (0) 1908 568 844
 Fax: +44 (0) 1908 566 790
 email: uk@sge.com

SGE Deutschland GmbH
 Tel: +49 (0) 6151 860486
 Fax: +49 (0) 6151 860489
 email: germany@sge.com

SGE Japan Inc.
 Tel: +81 (45) 222 2885
 Fax: +81 (45) 222 2887
 email: japan@sge.com

SGE Europe Ltd. (France)
 Tel: +33 (0) 1 6929 8090
 Fax: +33 (0) 1 6929 0925
 email: france@sge.com

SGE (Italia) Srl.
 Tel: +39 06 4429 0206
 Fax: +39 06 4429 0724
 email: sge.italia@tin.it

SGE India
 Tel: +91 (022) 471 5896
 Fax: +91 (022) 471 6592
 email: sgeindia@vsnl.com



www.sge.com

©Copyright 2004 SGE International Pty. Ltd.
 All rights reserved. PD-0247-H Rev 00 04/04

