

TEST METHODS FOR TOTAL CHLORINE IN NEW AND USED PETROLEUM
PRODUCTS (FIELD TEST KIT METHODS)

1.0 SCOPE AND APPLICATION

1.1 The method may be used to determine if a new or used petroleum product meets or exceeds requirements for total halogen measured as chloride. An analysis of the chlorine content of petroleum products is often required prior to their use as a fuel. The method is specifically designed for used oils permitting onsite testing at remote locations by nontechnical personnel to avoid the delays for laboratory testing.

1.2 In these field test methods, the entire analytical sequence, including sampling, sample pretreatment, chemical reactions, extraction, and quantification, are combined in a single kit using predispensed and encapsulated reagents. The overall objective is to provide a simple, easy to use procedure, permitting nontechnical personnel to perform a test with analytical accuracy outside of a laboratory environment in under 10 minutes. One of the kits is preset at 1,000 $\mu\text{g/g}$ total chlorine to meet regulatory requirements for used oils. The other kits provide quantitative results over a range of 750 to 7,000 $\mu\text{g/g}$ and 300 to 4,000 $\mu\text{g/g}$.

2.0 SUMMARY OF METHOD

2.1 The oil sample (around 0.4 g by volume) is dispersed in a solvent and reacted with a mixture of metallic sodium catalyzed with naphthalene and diglyme at ambient temperature. This process converts all organic halogens to their respective sodium halides. All halides in the treated mixture, including those present prior to the reaction, are then extracted into an aqueous buffer, which is then titrated with mercuric nitrate using diphenyl carbazone as the indicator. The end point of the titration is the formation of the blue-violet mercury diphenylcarbazone complex. Bromide and iodide are titrated and reported as chloride.

2.2 Reagent quantities are preset in the fixed end point kit (Method A) so that the color of the solution at the end of the titration indicates whether the sample is above 1,000 $\mu\text{g/g}$ chlorine (yellow) or below 1,000 $\mu\text{g/g}$ chlorine (blue).

2.3 The first quantitative kit (Method B) involves a reverse titration of a fixed volume of mercuric nitrate with the extracted sample such that the end point is denoted by a change from blue to yellow in the titration vessel over the range of the kit (750 to 7,000 $\mu\text{g/g}$). The final calculation is based on the assumption that the oil has a specific gravity of 0.9 g/cm^3 .

2.4 The second quantitative kit (Method C) involves a titration of the extracted sample with mercuric nitrate by means of a 1-mL microburette such that the end point is denoted by a change from pale yellow to red-violet over the range of the kit (300 to 4,000 $\mu\text{g/g}$). The concentration of chlorine in the original oil is then read from a scale on the microburette.

NOTE: Warning--All reagents are encapsulated or contained within ampoules. Strict adherence to the operational procedures included with the kits as well as accepted safety procedures (safety glasses and gloves) should be observed.

NOTE: Warning--When crushing the glass ampoules, press firmly in the center of the ampoule once. Never attempt to recrush broken glass because the glass may come through the plastic and cut fingers.

NOTE: Warning--In case of accidental breakage onto skin or clothing, wash with large amounts of water. All the ampoules are poisonous and should not be taken internally.

NOTE: Warning--The gray ampoules contain metallic sodium. Metallic sodium is a flammable water-reactive solid.

NOTE: Warning--Do not ship kits on passenger aircraft. Dispose of used kits properly.

NOTE: Caution--When the sodium ampoule in either kit is crushed, oils that contain more than 25% water will cause the sample to turn clear to light gray. Under these circumstances, the results may be biased excessively low and should be disregarded.

3.0 INTERFERENCES

3.1 Free water, as a second phase, should be removed. However, this second phase can be analyzed separately for chloride content if desired.

METHOD A

FIXED END POINT TEST KIT METHOD

4.0A APPARATUS AND MATERIALS

4.1A The CLOR-D-TECT 1000¹ is a complete self-contained kit. It includes: a sampling tube to withdraw a fixed sample volume for analysis; a polyethylene test tube #1 into which the sample is introduced for dilution and reaction with metallic sodium; and a polyethylene tube #2 containing a buffered aqueous extractant, the mercuric nitrate titrant, and diphenyl carbazone indicator. Included are instructions to conduct the test and a color chart to aid in determining the end point.

5.0A REAGENTS

5.1A Purity of reagents. Reagent-grade chemicals shall be used in all tests. Unless otherwise indicated, it is intended that all reagents shall conform to the specifications of the Committee on Analytical Reagents of the American Chemical Society, where such specifications are available. Other grades may be used, provided it is first ascertained that the reagent is of sufficiently high purity to permit its use without lessening the accuracy of the determination.

5.2A All necessary reagents are contained within the kit.

5.3A The kit should be examined upon opening to see that all of the components are present and that all the ampoules (4) are in place and not leaking. The liquid in Tube #2 (yellow cap) should be approximately 1/2 in. above the 5-mL line and the tube should not be leaking. The ampoules are not supposed to be completely full.

6.0A SAMPLE COLLECTION, PRESERVATION, AND HANDLING

6.1A All samples must be collected using a sampling plan that addresses the considerations discussed in Chapter Nine.

6.2A Because the collected sample will be analyzed for total halogens, it should be kept headspace free and refrigerated prior to preparation and analysis to minimize volatilization losses of organic halogens. Because waste oils may contain toxic and/or carcinogenic substances, appropriate field and laboratory safety procedures should be followed.

7.0A PROCEDURE

7.1A Preparation. Open analysis carton, remove contents, mount plastic test tubes in the provided holder. Remove syringe and glass sampling capillary from foil pouch.

¹Available from Dexsil Corporation, One Hamden Park Drive, Hamden, CT 06517.

NOTE: Perform the test in a warm, dry area with adequate light. In cold weather, a truck cab is sufficient. If a warm area is not available, Step 7.3A should be performed while warming Tube #1 in palm of hand.

7.2A Sample introduction. Remove white cap from Tube #1. Using the plastic syringe, slowly draw the oil up the capillary tube until it reaches the flexible adapter tube. Wipe excess oil from the tube with the provided tissue, keeping capillary vertical. Position capillary tube into Tube #1, and detach adapter tubing, allowing capillary to drop to the bottom of the tube. Replace white cap on tube. Crush the capillary by squeezing the test tube several times, being careful not to break the glass reagent ampoules.

7.3A Reaction. Break the lower (colorless) capsule containing the clear diluent solvent by squeezing the sides of the test tube. Mix thoroughly by shaking the tube vigorously for 30 seconds. Crush the upper grey ampoule containing metallic sodium, again by squeezing the sides of the test tube. Shake vigorously for 20 seconds. Allow reaction to proceed for 60 seconds, shaking intermittently several times while timing with a watch.

NOTE: Caution--Always crush the clear ampoule in each tube first. Otherwise, stop the test and start over using another complete kit. False (low) results may occur and allow a contaminated sample to pass without detection if clear ampoule is not crushed first.

7.4A Extraction. Remove caps from both tubes. Pour the clear buffered extraction solution from Tube #2 into Tube #1. Replace the white cap on Tube #1, and shake vigorously for 10 seconds. Vent tube by partially unscrewing the dispenser cap. Close cap securely, and shake for an additional 10 seconds. Vent again, tighten cap, and stand tube upside down on white cap. Allow phases to separate for 2 minutes.

7.5A Analysis. Put filtration funnel into Tube #2. Position Tube #1 over funnel and open nozzle on dispenser cap. Squeeze the sides of Tube #1 to dispense the clear aqueous lower phase through the filter into Tube #2 to the 5 mL line on Tube #2. Remove the filter funnel. Replace the yellow cap on Tube #2 and close the nozzle on the dispenser cap. Break the colorless lower capsule containing mercuric nitrate solution by squeezing the sides of the tube, and shake for 10 seconds. Then break the upper colored ampoule containing the diphenylcarbazone indicator, and shake for 10 seconds. Observe color immediately.

7.6A Interpretation of results

7.6.1A Because all reagent levels are preset, calculations are not required. A blue solution in Tube #2 indicates a chlorine content in the original oil of less than 1,000 $\mu\text{g/g}$, and a yellow color indicates that the chlorine concentration is greater than 1,000 $\mu\text{g/g}$. Refer to the color chart enclosed with the kit in interpreting the titration end point.

7.6.2A Report the results as < or > 1,000 $\mu\text{g/g}$ chlorine in the oil sample.

8.0A QUALITY CONTROL

8.1A Refer to Chapter One for specific quality control procedures.

8.2A Each sample should be tested two times. If the results do not agree, then a third test must be performed. Report the results of the two that agree.

9.0A METHOD PERFORMANCE

9.1A No formal statement is made about either the precision or bias of the overall test kit method for determining chlorine in used oil because the result merely states whether there is conformance to the criteria for success specified in the procedure, (i.e., a blue or yellow color in the final solution). In a collaborative study, eight laboratories analyzed four used crankcase oils and three fuel oil blends with crankcase in duplicate using the test kit. Of the resulting 56 data points, 3 resulted in incorrect classification of the oil's chlorine content (Table 1). A data point represents one duplicate analysis of a sample. There were no disagreements within a laboratory on any duplicate determinations.

TABLE 1.
PRECISION AND BIAS INFORMATION FOR METHOD A-
FIXED END POINT TEST KIT METHOD

Expected concentration, µg/g	Expected results, µg/g	Percent correct ^a	Percent agreement ^b	
			Within	Between
320	< 1,000	100	100	100
480	< 1,000	100	100	100
920	< 1,000	100	100	100
1,498	> 1,000	87	100	87
1,527	> 1,000	75	100	75
3,029	> 1,000	100	100	100
3,045	> 1,000	100	100	100

^aPercent correct--percent correctly identified as above or below 1,000 µg/g.

^bPercent agreement--percent agreement within or between laboratories.

METHOD 9077, METHOD A
 FIXED END POINT TEST KIT METHOD

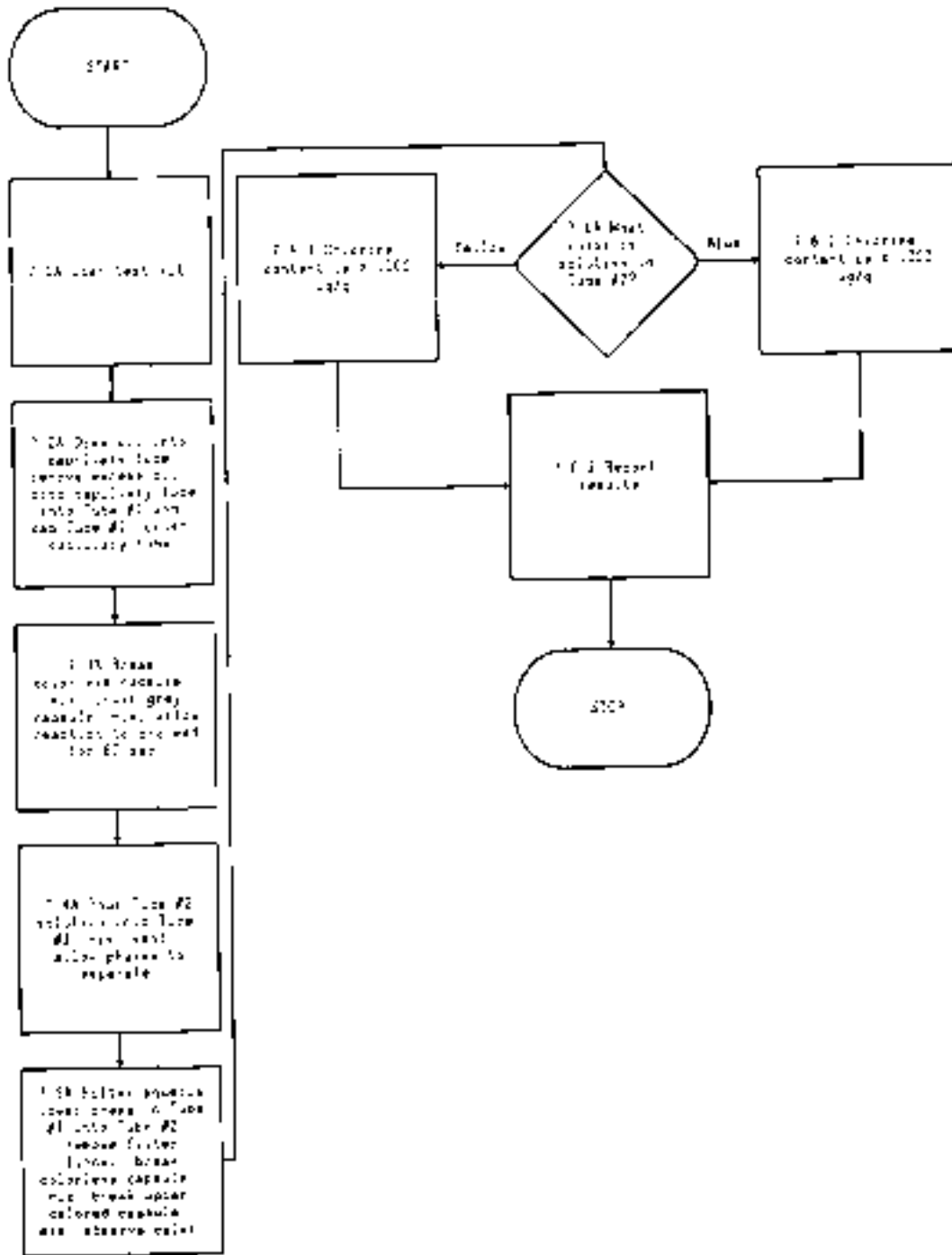

METHOD B

REVERSE TITRATION QUANTITATIVE END POINT TEST KIT METHOD

4.0B APPARATUS AND MATERIALS

4.1B QuantiClor² kit components (see Figure 1).

4.1.1B Plastic reaction bottle: 1 oz, with flip-top dropper cap and a crushable glass ampoule containing sodium.

4.1.2B Plastic buffer bottle: contains 9.5 mL of aqueous buffer solution.

4.1.3B Titration vial: contains buffer bottle and indicator-impregnated paper.

4.1.4B Glass vial: contains 2.0 mL of solvents.

4.1.5B Micropipet and plunger, 0.25 mL.

4.1.6B Activated carbon filtering column.

4.1.7B Titret and valve assembly.

4.2B The reagents needed for the test are packaged in disposable containers.

4.3B The procedure utilizes a Titret. Titrets[®] are hand-held, disposable cells for titrimetric analysis. A Titret is an evacuated glass ampoule (13 mm diameter) that contains an exact amount of a standardized liquid titrant. A flexible valve assembly is attached to the tip of the ampoule. Titrets[®] employ the principle of reverse titration; that is, small doses of sample are added to the titrant to the appearance of the end point color. The color change indicates that the equivalency point has been reached. The flow of the sample into the Titret may be controlled by using an accessory called a Titrettor[™].

5.0B REAGENTS

5.1B The crushable glass ampoule, which is inside the reaction bottle, contains 85 mg of metallic sodium in a light oil dispersion.

5.2B The buffer bottle contains 0.44 g of $\text{NaH}_2\text{PO}_4 \cdot 2\text{H}_2\text{O}$ and 0.32 mL of HNO_3 in distilled water.

5.3B The glass vial contains 770 mg Stoddard Solvent (CAS No. 8052-41-3), 260 mg toluene, 260 mg butyl ether, 260 mg diglyme, 130 mg naphthalene, and 70 mg demulsifier.

²Quanti-Chlor Kit, Titrets[®], and Titrettor[™] are manufactured by Chemetrics, Inc., Calverton, VA 22016. U.S. Patent No. 4,332,769.

5.4B The Titret contains 1.12 mg mercuric nitrate in distilled water.

5.5B The indicator-impregnated paper contains approximately 0.3 mg of diphenylcarbazone and 0.2 mg of brilliant yellow.

6.0B SAMPLE COLLECTION, PRESERVATION, AND HANDLING

See Section 6.0A of Method A.

7.0B PROCEDURE

7.1B Shake the glass vial and pour its contents into the reaction bottle.

7.2B Fill the micropipet with a well-shaken oil sample by pulling the plunger until its top edge is even with the top edge of the micropipet. Wipe off the excess oil and transfer the sample into the reaction bottle (see Figure 2.1).

7.3B Gently squeeze most of the air out of the reaction bottle (see Figure 2.2). Cap the bottle securely, and shake vigorously for 30 seconds.

7.4B Crush the sodium ampoule by pressing against the outside wall of the reaction bottle (see Figure 2.3).

CAUTION: Samples containing a high percentage of water will generate heat and gas, causing the reaction bottle walls to expand. To release the gas, briefly loosen the cap.

7.5B Shake the reaction bottle vigorously for 30 seconds.

7.6B Wait 1 minute. Shake the reaction bottle occasionally during this time.

7.7B Remove the buffer bottle from the titration vial, and slowly pour its contents into the reaction bottle (see Figure 2.4).

7.8B Cap the reaction bottle and shake gently for a few seconds. As soon as the foam subsides, release the gas by loosening the cap. Tighten the cap, and shake vigorously for 30 seconds. As before, release any gas that has formed, then turn the reaction bottle upside down (see Figure 2.5).

7.9B Wait 1 minute.

7.10B While holding the filtering column in a vertical position, remove the plug. Gently tap the column to settle the carbon particles.

7.11B Keeping the reaction bottle upside down, insert the flip top into the end of the filtering column and position the column over the titration vial (see Figure 2.6). Slowly squeeze the lower aqueous layer out of the reaction bottle and into the filtering column. Keep squeezing until the first drop of oil is squeezed out.

NOTE: Caution--The aqueous layer should flow through the filtering column into the titration vial in about 1 minute. In rare cases, it may be necessary to gently tap the column to begin the flow. The indicator paper should remain in the titration vial.

7.12B Cap the titration vial and shake it vigorously for 10 seconds.

7.13B Slide the flexible end of the valve assembly over the tapered tip of the Titret so that it fits snugly (see Figure 3.1).

7.14B Lift (see Figure 3.2) the control bar and insert the assembled Titret into the Titrettor™.

7.15B Hold the Titrettor™ with the sample pipe in the sample, and press the control bar to snap the pre-scored tip of the Titret (see Figure 3.3).

NOTE: Caution--Because the Titret is sealed under vacuum, the fluid inside may be agitated when the tip snaps.

7.16B With the tip of the sample pipe in the sample, briefly press the control bar to pull in a SMALL amount of sample (see Figure 3.3). The contents of the Titret will turn purple.

CAUTION: During the titration, there will be some undissolved powder inside the Titret. This does not interfere with the accuracy of the test.

7.17B Wait 30 seconds.

7.18B Gently press the control bar again to allow another SMALL amount of the sample to be drawn into the Titret.

CAUTION: Do not press the control bar unless the sample pipe is immersed in the sample. This prevents air from being drawn into the Titret.

7.19B After each addition, rock the entire assembly to mix the contents of the Titret. Watch for a color change from purple to very pale yellow.

7.20B Repeat Steps 7.18B and 7.19B until the color change occurs.

CAUTION: The end point color change (from purple to pale yellow) actually goes through an intermediate gray color. During this intermediate stage, extra caution should be taken to bring in SMALL amounts of sample and to mix the Titret contents well.

7.21B When the color of the liquid in the Titret changes to PALE YELLOW, remove the Titret from the Titrettor™. Hold the Titret in a vertical position and carefully read the test result on the scale opposite the liquid level.

7.22B Calculation

7.22.1B To obtain results in micrograms per gram total chlorine, multiply scale units on the Titret by 1.3 and then subtract 200.

8.0B QUALITY CONTROL

8.1B Refer to Chapter One for specific quality control procedures.

8.2B Each sample should be tested two times. If the results do not agree to within 10%, expressed as the relative percent difference of the results, a third test must be performed. Report the results of the two that agree.

9.0B METHOD PERFORMANCE

9.1B These data are based on 49 data points obtained by seven laboratories who each analyzed four used crankcase oils and three fuel oil blends with crankcase in duplicate. A data point represents one duplicate analysis of a sample. There were no outlier data points or laboratories.

9.2B Precision. The precision of the method as determined by the statistical examination of interlaboratory test results is as follows:

Repeatability - The difference between successive results obtained by the same operator with the same apparatus under constant operating conditions on identical test material would exceed, in the long run, in the normal and correct operation of the test method, the following values only in 1 case in 20 (see Table 2):

$$\textit{Repeatability} = 0.31 x^*$$

*where x is the average of two results in $\mu\text{g/g}$.

Reproducibility - The difference between two single and independent results obtained by different operators working in different laboratories on identical test material would exceed, in the long run, the following values only in 1 case in 20:

$$\textit{Reproducibility} = 0.60 x^*$$

*where x is the average value of two results in $\mu\text{g/g}$.

9.3B Bias. The bias of this test method varies with concentration, as shown in Table 3:

$$\text{Bias} = \text{Amount found} - \text{Amount expected}$$

TABLE 2.
REPEATABILITY AND REPRODUCIBILITY FOR CHLORINE IN USED
OILS BY THE QUANTITATIVE END POINT TEST KIT METHOD

Average value, $\mu\text{g/g}$	Repeatability, $\mu\text{g/g}$	Reproducibility, $\mu\text{g/g}$
1,000	310	600
1,500	465	900
2,000	620	1,200
2,500	775	1,500
3,000	930	1,800

TABLE 3.
RECOVERY AND BIAS DATA FOR CHLORINE IN USED OILS BY THE
QUANTITATIVE END POINT TEST KIT METHOD

Amount expected $\mu\text{g/g}$	Amount found, $\mu\text{g/g}$	Bias, $\mu\text{g/g}$	Percent bias
320 (< 750) ^a	776	+16	+3
480 (< 750) ^a	782	+32	+4
920	1,020	+100	+11
1,498	1,129	-369	-25
1,527	1,434	-93	-6
3,029	1,853	-1,176	-39
3,045	2,380	-665	-22

^a The lower limit of the kit is 750 $\mu\text{g/g}$.

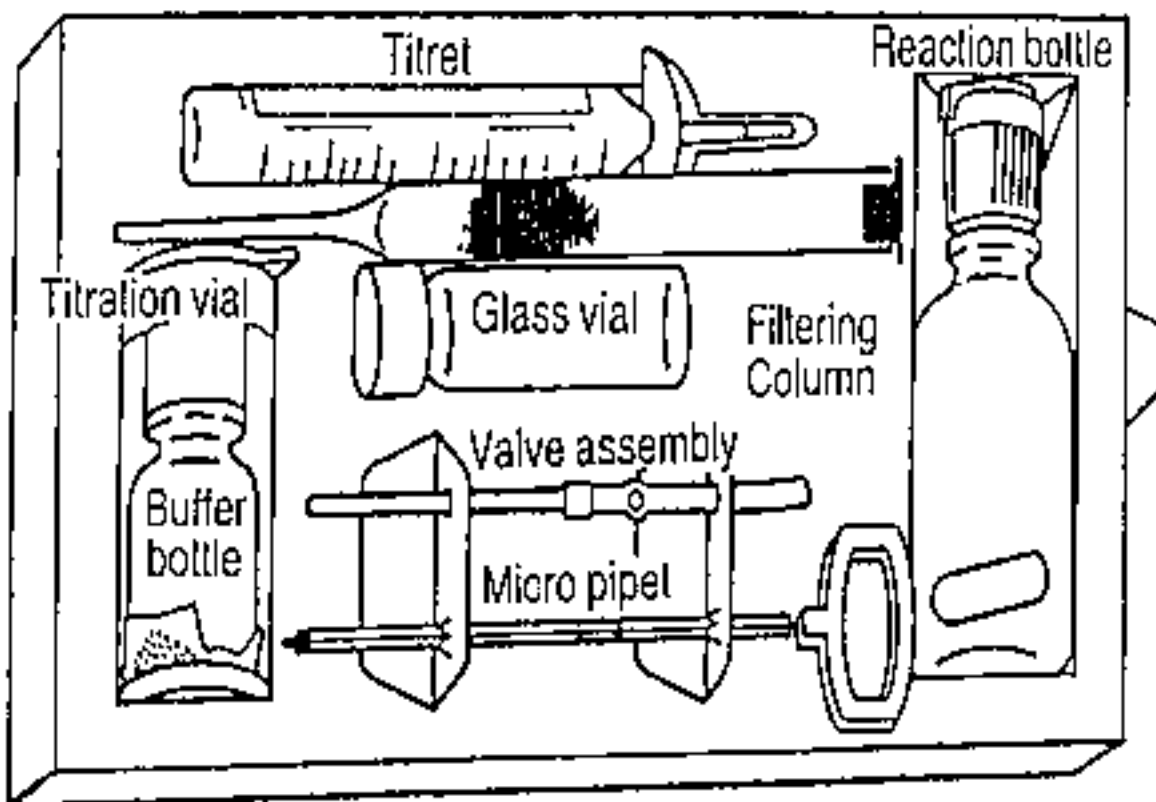

Figure 1. Components of CHEMetrics Total Chlorine in Waste Oil Test Kit (Cat. No. K2610).

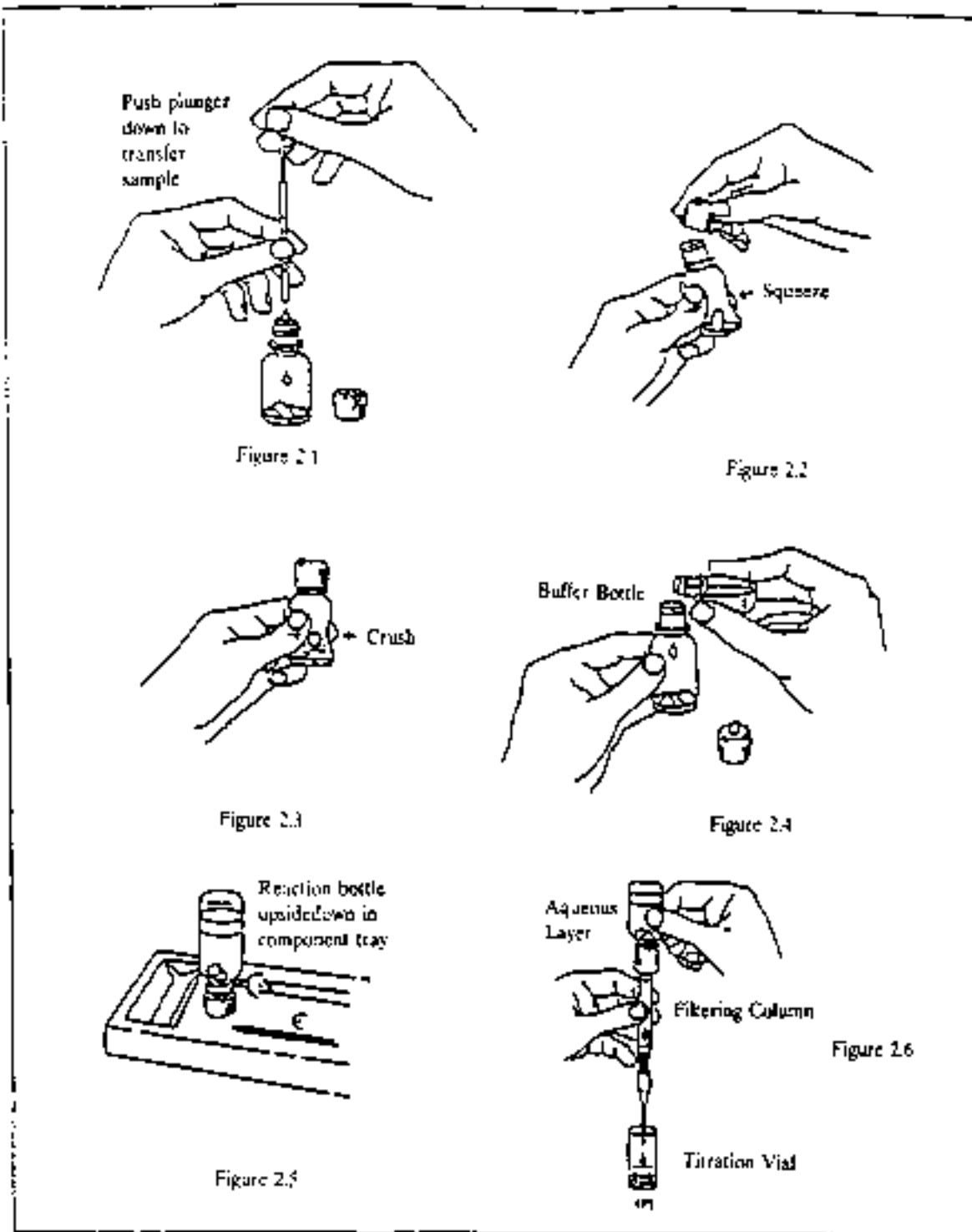
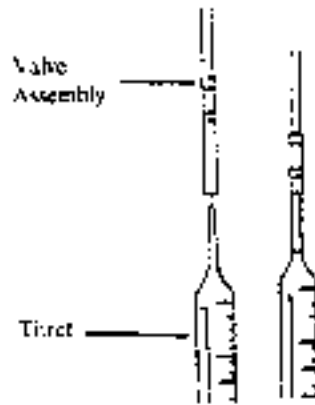

Figure 2. Reaction-Extraction Procedure.

Attaching the Valve Assembly

Figure 3.1



Snapping the Tip

Figure 3.2

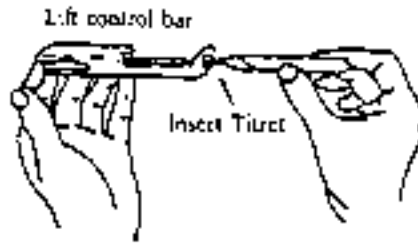

Performing the Analysis

Figure 3.3

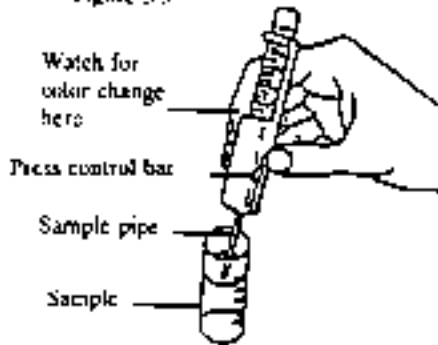

Reading the Result

Figure 3.4

Read scale units when color changes permanently

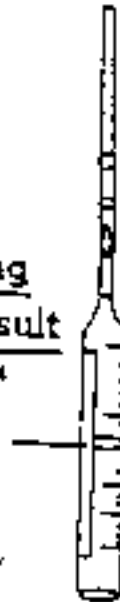
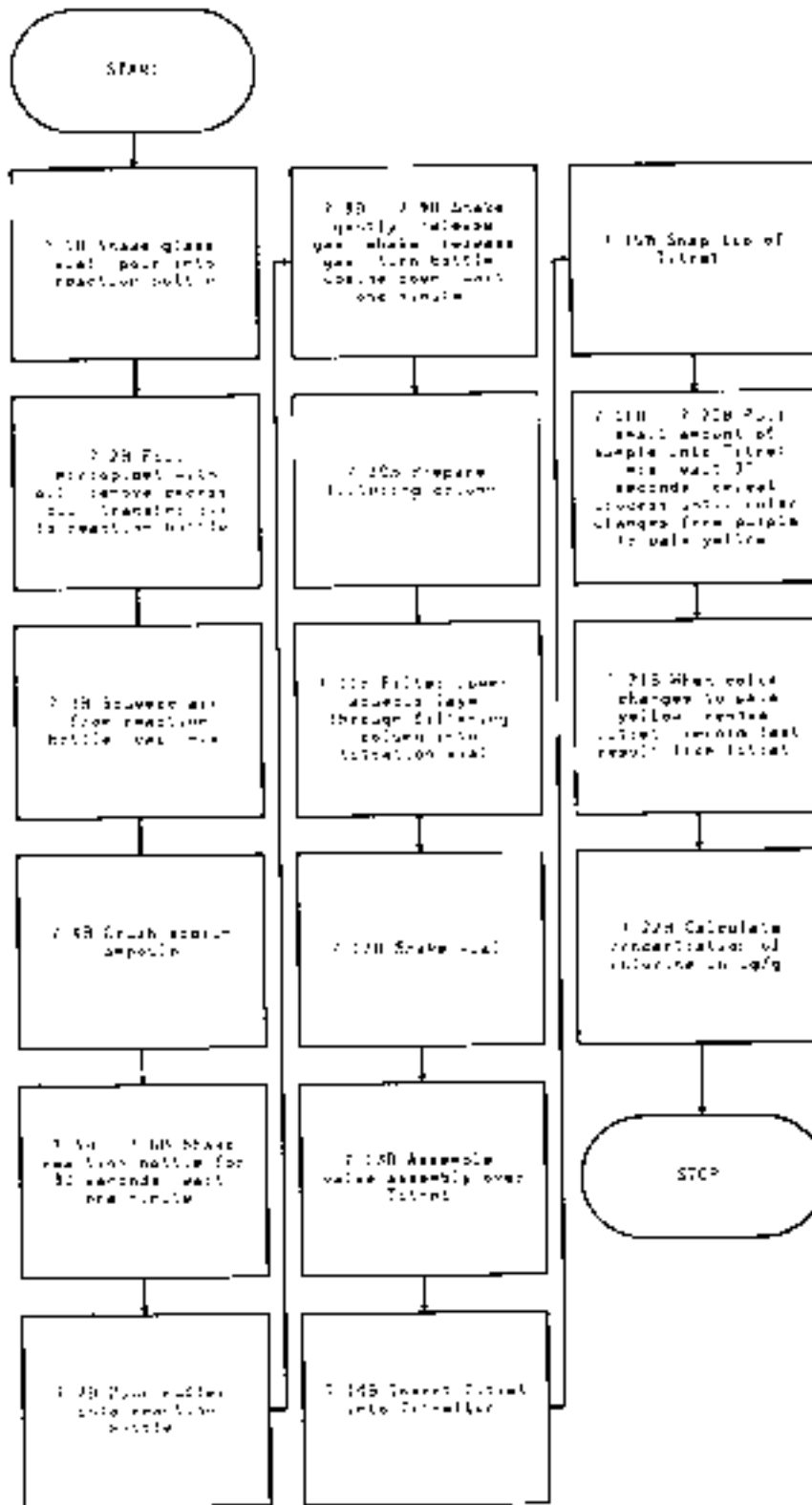

Figure 3. Titration Procedure

METHOD 9077, METHOD B
 REVERSE TITRATION QUANTITATIVE END POINT TEST KIT METHOD



METHOD C

DIRECT TITRATION QUANTITAVE END POINT TEST KIT METHOD

4.0C APPARATUS AND MATERIALS

4.1C The CHLOR-D-TECT Q4000³ is a complete self-contained kit. It includes: a sampling syringe to withdraw a fixed sample volume for analysis; a polyethylene test tube #1 into which the sample is introduced for dilution and reaction with metallic sodium; a polyethylene tube #2 containing a buffered aqueous extractant and the diphenylcarbazone indicator; a microburette containing the mercuric nitrate titrant; and a plastic filtration funnel. Also included are instructions to conduct the test.

5.0C REAGENTS

5.1C All necessary reagents are contained within the kit. The diluent solvent containing the catalyst, the metallic sodium, and the diphenylcarbazone are separately glass-encapsulated in the precise quantity required for analysis. A predispensed volume of buffer is contained in the second polyethylene tube. Mercuric nitrate titrant is also supplied in a sealed titration burette.

5.2C The kit should be examined upon opening to see that all of the components are present and that all ampoules (3) are in place and not leaking. The liquid in Tube #2 (clear cap) should be approximately 1/2 in. above the 5-mL line and the tube should not be leaking. The ampoules are not supposed to be completely full.

6.0C SAMPLE COLLECTION, PRESERVATION, AND HANDLING

6.1C See Section 6.0A of Method A.

7.0C PROCEDURE

7.1C Preparation. Open analysis carton, remove contents, mount plastic test tubes in the provided holder.

NOTE: Perform the test in a warm, dry area with adequate light. In cold weather, a truck cab is sufficient. If a warm area is not available, Step 7.3C should be performed while warming Tube #1 in palm of hand.

7.2C Sample introduction. Unscrew the white dispenser cap from Tube #1. Slide the plunger in the empty syringe a few times to make certain that it slides easily. Place the top of the syringe in the oil sample to be tested, and pull back on the plunger until it reaches the stop and cannot be pulled further. Remove the syringe from the sample container, and wipe any excess oil from the outside of the syringe with the enclosed tissue. Place the tip of the syringe in Tube #1, and dispense the oil sample by depressing the plunger. Replace the white cap on the tube.

³Available from Dexsil Corporation, One Hamden Park Drive, Hamden, CT 06517.

7.3C Reaction. Break the lower (colorless) capsule containing the clear diluent solvent by squeezing the sides of the test tube. Mix thoroughly by shaking the tube vigorously for 30 seconds. Crush the upper grey ampoule containing metallic sodium, again by squeezing the sides of the test tube. Shake vigorously for 20 seconds. Allow reaction to proceed for 60 seconds, shaking intermittently several times while timing with a watch.

CAUTION: Always crush the clear ampoule in each tube first. Otherwise, stop the test and start over using another complete kit. False (low) results may occur and allow a contaminated sample to pass without detection if clear ampoule is not crushed first.

7.4C Extraction. Remove caps from both tubes. Pour the clear buffered extraction solution from Tube #2 into Tube #1. Replace the white cap on Tube #1, and shake vigorously for 10 seconds. Vent tube by partially unscrewing the dispenser cap. Close cap securely, and shake for an additional 10 seconds. Vent again, tighten cap, and stand tube upside down on white cap. Allow phases to separate for 2 minutes.

NOTE: Tip Tube #2 to an angle of only about 45°. This will prevent the holder from sliding out.

7.5C Analysis. Put filtration funnel into Tube #2. Position Tube #1 over funnel and open nozzle on dispenser cap. Squeeze the sides of Tube #1 to dispense the clear aqueous lower phase through the filter into Tube #2 to the 5-mL line on Tube #2. Remove the filter funnel, and close the nozzle on the dispenser cap. Place the plunger rod in the titration burette and press until it clicks into place. Break off (do not pull off) the tip on the titration burette. Insert the burette into Tube #2, and tighten the cap. Break the colored ampoule, and shake gently for 10 seconds. Dispense titrant dropwise by pushing down on burette rod in small increments. Shake the tube gently to mix titrant with solution in Tube #2 after each increment. Continue adding titrant until solution turns from yellow to red-violet. An intermediate pink color may develop in the solution, but should be disregarded. Continue titrating until a true red-violet color is realized. The chlorine concentration of the original oil sample is read directly off the titrating burette at the tip of the black plunger. Record this result immediately as the red-violet color will fade with time.

8.0C QUALITY CONTROL

8.1C Refer to Chapter One for specific quality control procedures.

8.2C Each sample should be tested two times. If the results do not agree to within 10%, expressed as the relative percent difference of the results, a third test must be performed. Report the results of the two that agree.

9.0C METHOD PERFORMANCE

9.1C These data are based on 96 data points obtained by 12 laboratories who each analyzed six used crankcase oils and two fuel oil blends with crankcase in duplicate. A data point represents one duplicate analysis of a sample.

9.2C Precision. The precision of the method as determined by the statistical examination of interlaboratory test results is as follows:

Repeatability - The difference between successive results obtained by the same operator with the same apparatus under constant operating conditions on identical test material would exceed, in the long run, in the normal and correct operation of the test method, the following values only in 1 case in 20 (see Table 4):

$$\text{Repeatability} = 0.175 x^*$$

*where x is the average of two results in $\mu\text{g/g}$.

Reproducibility - The difference between two single and independent results obtained by different operators working in different laboratories on identical test material would exceed, in the long run, the following values only in 1 case in 20:

$$\text{Reproducibility} = 0.331 x^*$$

*where x is the average value of two results in $\mu\text{g/g}$.

9.3C Bias. The bias of this test method varies with concentration, as shown in Table 5:

$$\text{Bias} = \text{Amount found} - \text{Amount expected}$$

10.0 REFERENCE

1. Gaskill, A.; Estes, E.D.; Hardison, D.L.; and Myers, L.E. Validation of Methods for Determining Chlorine in Used Oils and Oil Fuels. Prepared for U.S. Environmental Protection Agency, Office of Solid Waste. EPA Contract No. 68-01-7075, wA 80. July 1988.

TABLE 4.
 REPEATABILITY AND REPRODUCIBILITY FOR CHLORINE IN USED
 OILS BY THE QUANTITATIVE END POINT TEST KIT METHOD

Average value, μg/g	Repeatability, μg/g	Reproducibility, μg/g
500	88	166
1,000	175	331
1,500	263	497
2,000	350	662
2,500	438	828
3,000	525	993
4,000	700	1,324

TABLE 5.
 RECOVERY AND BIAS DATA FOR CHLORINE IN USED OILS BY THE
 QUANTITATIVE END POINT TEST KIT METHOD

Amount expected, μg/g	Amount found, μg/g	Bias, μg/g	Percent bias
664	695	31	+5
964	906	-58	-6
1,230	1,116	-114	-9
1,445	1,255	-190	-13
2,014	1,618	-396	-20
2,913	2,119	-794	-27
3,812	2,776	-1,036	-27
4,190	3,211	-979	-23

METHOD 9077, METHOD C
 DIRECT TITRATION QUANTITATIVE END POINT TEST KIT METHOD

