

METHOD 9022

TOTAL ORGANIC HALIDES (TOX) BY NEUTRON ACTIVATION ANALYSIS

1.0 SCOPE AND APPLICATION

1.1 Method 9022 determines Total Organic Halides (TOX) in aqueous samples. The method uses a carbon adsorption procedure identical to that of Method 9020 (TOX analysis using a microcoulometric-titration detector), irradiation by neutron bombardment, and then detection using a gamma-ray detector.

1.2 Method 9022 detects all organic halides containing chlorine, bromine, and iodine that are adsorbed by granular activated carbon under the conditions of the method. Each halogen can be quantitated independently.

1.3 Method 9022 is restricted to use by, or under the supervision of, analysts experienced in the operation of neutron activation analysis and familiar with spectral interferences.

1.4 This method, which may be used in place of Method 9020, has the advantage of determining the individual concentrations of the halogens chlorine, bromine, and iodine in addition to TOX.

2.0 SUMMARY OF METHOD

2.1 A sample of water that has been protected against the loss of volatiles by the elimination of headspace in the sampling container, and that is free of undissolved solids, is passed through a column containing 40 mg of granular activated carbon (GAC). The column is washed to remove any trapped inorganic halides. The GAC sample is exposed to thermal neutron bombardment, creating a radioactive isotope. Gamma-ray emission, which is unique to each halogen, is counted. The areas of the resulting peaks are directly proportional to the concentrations of the halogens.

3.0 INTERFERENCES

3.1 Method interferences may be caused by contaminants, reagents, glassware, and other sample processing hardware. All these materials must be routinely demonstrated to be free from interferences under the conditions of the analysis by running method blanks.

3.1.1 Glassware must be scrupulously cleaned. Clean all glassware as soon as possible after use by treating with chromatic cleaning solution. This should be followed by detergent washing in hot water. Rinse with tap water and distilled water and drain dry; glassware which is not volumetric should, in addition, be heated in a muffle furnace at

400°C for 15 to 30 min. Volumetric ware should not be heated in a muffle furnace. Glassware should be sealed and stored in a clean environment after drying and cooling to prevent any accumulation of dust or other contaminants.

3.1.2 The use of high-purity reagents and gases helps to minimize interference problems.

3.2 Purity of the activated carbon must be verified before use. Only carbon samples that register less than 2,000 ng Cl⁻/40 mg GAC should be used. The stock of activated carbon should be stored in its granular form in a glass container with a Teflon seal. Exposure to the air must be minimized, especially during and after milling and sieving the activated carbon. No more than a 2-wk supply should be prepared in advance. Protect carbon at all times from all sources of halogenated organic vapors. Store prepared carbon and packed columns in glass containers with Teflon seals.

4.0 APPARATUS AND MATERIALS

4.1 Adsorption system (a general schematic of the adsorption system is shown in Figure 1):

4.1.1 **Adsorption module** with pressurized sample and nitrate-wash reservoirs.

4.1.2 **Adsorption columns:** Pyrex, 5-cm long x 6-mm O.D. x 2-mm I.D.

4.1.3 **Granular activated carbon (GAC):** Filtrasorb-400, Calgon-APC or equivalent, ground or milled, and screened to a 100/200 mesh range. Upon combustion of 40 mg of GAC, the apparent halide background should be 1000 ng Cl⁻ equivalent or less.

4.1.4 **Cerafelt** (available from Johns-Manville) or equivalent: Form this material into plugs using a 2-mm-I.D. stainless steel borer with ejection rod to hold 40 mg of GAC in the adsorption columns.

CAUTION: Do not touch this material with your fingers. Oily residue will contaminate carbon.

4.1.5 **Column holders.**

4.1.6 **Volumetric flasks:** 100-mL, 50-mL.

4.2 Containers suitable for containment of samples and standards during irradiation (e.g., 1/5-dram polyethylene snap-cap vial).

4.3 Sample introduction system and a reactor generating a thermal neutron flux capable of achieving enough halogen activity for counting purposes (e.g., a reactor having a neutron flux of 5×10^{12} neutrons/cm²/sec).

4.4 A gamma-ray detector and data-handling system capable of resolving the halogen peaks from potential interferences and background.

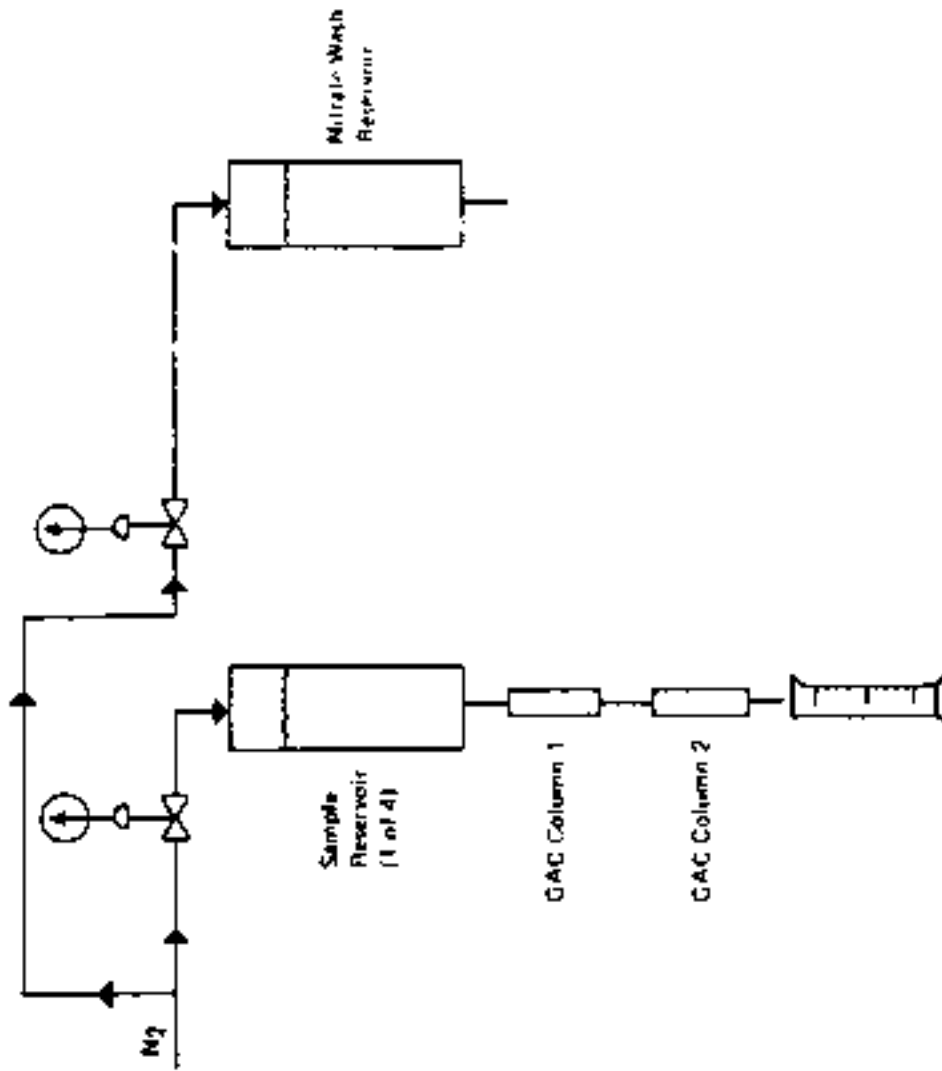

Figure 1 Schematic diagram of air sorption system.

5.0 REAGENTS

5.1 Prepurified nitrogen.

5.2 ASTM Type II water (ASTM D1193): Water should be monitored for impurities.

5.3 Nitrate-wash solution (5,000 mg NO₃⁻/L): Prepare a nitrate-wash solution by transferring approximately 8.2 g of potassium nitrate (KNO₃) into a 1-liter volumetric flask and diluting to volume with Type II water.

5.4 Acetone and nanograde hexane (50% v/v mixture).

5.5 Sodium sulfite, 0.1 M (ACS reagent grade, 12.6 g/L).

5.6 Concentrated nitric acid (HNO₃): Reagent grade.

5.7 Standards: 25-ug Cl, 2.5-ug Br, and 2.5-ug I.

5.8 Radioactive standards to be used for calibrating gamma-ray detection systems.

5.9 Trichlorophenol solution, stock (1 uL = 10 ug Cl⁻): Prepare a stock solution by accurately weighing accurately 1.856 g of trichlorophenol into a 100-mL volumetric flask. Dilute to volume with methanol.

5.10 Trichlorophenol standard, adsorption efficiency (100 ug Cl⁻/liter): Prepare an adsorption-efficiency standard by injecting 10 uL of stock solution into 1 liter of Type II water.

6.0 SAMPLE COLLECTION, PRESERVATION, AND HANDLING

6.1 All samples must have been collected using a sampling plan that addresses the considerations discussed in Chapter Nine of this manual.

6.2 All samples should be collected in bottles with Teflon septa (e.g., Pierce #12722 or equivalent) and be protected from light. If this is not possible, use amber glass, 250-mL, fitted with Teflon-lined caps. Foil may be substituted for Teflon if the sample is not corrosive. Samples must be protected against loss of volatiles by eliminating headspace in the container. Containers must be washed and muffled at 400°C before use, to minimize contamination.

6.3 All glassware must be dried prior to use according to the method discussed in Paragraph 3.1.1.

7.0 PROCEDURE

7.1 Sample preparation:

7.1.1 Special care should be taken in handling the sample in order to minimize the loss of volatile organohalides. The adsorption procedure should be performed simultaneously on the front and back columns.

7.1.2 Reduce residual chlorine by adding sulfite (1 mL of 0.1 M sulfite per liter of sample). Sulfite should be added at the time of sampling if the analysis is meant to determine the TOX concentration at the time of sampling. It should be recognized that TOX may increase on storage of the sample. Samples should be stored at 4°C without headspace.

7.1.3 Samples containing undissolved solids should be centrifuged and decanted.

7.1.4 Adjust the pH of the sample to approximately 2 with concentrated HNO₃ just prior to adding the sample to the reservoir.

7.2 Calibration:

7.2.1 Check the adsorption efficiency of each newly prepared batch of carbon by analyzing 100 mL of the adsorption efficiency standard, in duplicate, along with duplicates of the blank standard. The net recovery should be within 5% of the standard value.

7.2.2 Nitrate-wash blanks (method blanks): Establish the repeatability of the method background each day by first analyzing several nitrate-wash blanks. Monitor this background by spacing nitrate-wash blanks between each group of eight analysis determinations. The nitrate-wash blank values are obtained on single columns packed with 40 mg of activated carbon. Wash with the nitrate solution, as instructed for sample analysis, and then analyze the carbon.

7.2.3 Prior to each day's operation, calibrate the instrument using radioactive standards (e.g., cobalt-60 and radium-226 sources). The instrument is calibrated such that gamma rays from the standards fall within one channel of their true energies. A 100-sec blank is then counted to verify that no stray radioactive sources are within sensing distance of the detector. As data are obtained throughout the day, peak locations in the standards are monitored to ensure there is no electronic drift of the instrument. If drift is noted, the system must be recalibrated.

7.3 Adsorption procedure:

7.3.1 Connect in series two columns, each containing 40 mg of 100/200-mesh activated carbon.

7.3.2 Fill the sample reservoir and pass a metered amount of sample through the activated-carbon columns at a rate of approximately 3 mL/min.

NOTE: 100 mL of sample is the preferred volume for concentrations of TOX between 5 and 500 ug/L, 50 mL for 501 to 1000 ug/L, and 25 mL for 1,001 to 2,000 ug/L.

7.3.3 Wash the columns-in-series with at least 2 mL of the 5,000-mg/L nitrate solution at a rate of approximately 2 mL/min to displace inorganic chloride ions.

7.4 Activation:

7.4.1 After the quartz collection tube with the GAC is removed from the extraction unit, the GAC and cerafelt pads are extruded, using the packing rod, into a prewashed plastic container (e.g., 1/5-dram polyethylene snap-cap vial). The vial has been prewashed to remove inorganic and organic chlorine by a soak in distilled water, followed by storage in a glass jar containing 50% v/v acetone and hexane. After extrusion, the vial is removed by forceps and air-dried to remove residual water, acetone, and hexane. After extrusion, the vial is snapped shut, the hinge removed with a scalpel blade, the cap heat-sealed to the vial with an electric soldering gun reserved for that purpose, and a single-digit number placed on the vial with a marker pen.

7.4.2 Samples plus a similar vial containing 25 ug Cl, 2.5 ug Br, and 2.5 ug I standards are then introduced into the reactor, generally by placing them together in a 5-dram polyethylene vial and inserting them into a pneumatic-tube transfer "rabbit" for neutron irradiation. Irradiation is typically for a 15-min period at a thermal neutron irradiation flux of 5×10^{12} neutrons/cm²/sec. After returning from the reactor, the rabbit is allowed to "cool" for 20 min to allow short-lived radioisotopes (primarily A1) present in the GAC to decay.

7.5 Detection:

7.5.1 Analysis is performed using a lithium-drifted germanium [Ge(Li)] gamma-ray detector with an amplifier and a 4096-channel memory unit for data storage. The analyses can be performed either manually, with the operator changing samples and transferring the data to magnetic tape, or automatically, with both functions performed by an automatic sample changer.

7.5.2 Analysis begins by counting the standard and samples for a suitable time period (e.g., 200-sec "live" time for the standards and samples). The operator records the time intervals between samples and the "dead" time of each sample in a logbook for later use in calculating halogen concentrations in each sample.

7.5.3 Breakthrough: The unpredictable nature of the background bias makes it especially difficult to recognize the extent of breakthrough of organohalides from one column to another. All second-

column measurements for a properly operating system should not exceed 10% of the two-column total measurement. If the 10% figure is exceeded, one of three events could have happened: (1) the first column was overloaded and a legitimate measure of breakthrough was obtained, in which case taking a smaller sample may be necessary; (2) channeling or some other failure occurred, in which case the sample may need to be rerun; or (3) a high random bias occurred, and the result should be rejected and the sample rerun. Because it may not be possible to determine which event occurred, a sample analysis should be repeated often enough to gain confidence in results. As a general rule, any analysis that is rejected should be repeated whenever a sample is available. In the event that repeated analyses show that the second column consistently exceeds the 10% figure and the total is too low for the first column to be saturated and the inorganic Cl is less than 20,000 times the organic chlorine value, then the result should be reported, but the data user should be informed of the problem. If the second-column measurement is equal to or less than the nitrate-wash blank value, the second-column value should be disregarded.

7.6 Calculations:

7.6.1 Chlorine, bromine, and iodine can be analyzed within a 200-sec counting period taking place 20 to 40 min after irradiation.

7.6.2 Chlorine is analyzed using the 1642-KeV gamma ray produced by 37.1-min ³⁸Cl. Bromine is analyzed using the 616-KeV gamma ray from 17.7-min ⁸⁰Br, and iodine is analyzed using the 442-KeV gamma ray produced by 25-min ¹²⁸I.

7.6.3 The calculation used for quantitation is:

$$\text{ppm halogen} = \frac{\text{cts unk.}}{\text{cts std.}} \times \frac{\text{counting time std.}}{\text{counting time unk.}} \times \frac{\text{ug in std.}}{\text{sample vol.}} \times e^{-\lambda t}$$

where:

cts unk. = the integrated area of the appropriate gamma-ray peak in the unknown with background subtracted and the total multiplied by 1 + [(% dead time unknown - % dead time std.)/200]. The latter correction is usually less than 4% and corrects for pile-up errors.

cts std. = the integrated area of the appropriate gamma-ray peak in the standard with background subtracted.

counting time std. = the "live" counting time in seconds of the standard.

counting time unk. = the "live" counting time in seconds of the unknown.

ug in std. = the number of micrograms of the stable element in question in the standard (25 for Cl, 2.5 for Br and I).

sample vol. = the volume of sample passed through the GAC column, in mL.

$e^{\lambda t}$ = the decay correction to bring all statistics back to $t = 0$;
 $\lambda = 0.693/t_{1/2}$, where $t_{1/2}$ = the half-life in minutes.

t = the time interval in minutes from the end of the count of the standard until the end of the count of the sample.

7.6.4 No further calculations are necessary as long as the final sample is counted within 40 min after the end of irradiation.

8.0 QUALITY CONTROL

8.1 All quality control data should be maintained and available for easy reference or inspection.

8.2 Before performing any analyses, the analyst must demonstrate the ability to generate acceptable accuracy and precision with this procedure by analyzing appropriate quality-control check samples.

8.3 The laboratory must develop and maintain a statement of method accuracy for their laboratory. The laboratory should update the accuracy statement regularly as new recovery measurements are made.

8.4 Employ a minimum of one blank per sample batch to determine if contamination is occurring.

8.5 Verify calibration with an independently prepared check standard every 15 samples.

8.6 Run one spike duplicate sample for every 10 samples. A duplicate sample is a sample brought through the whole sample preparation and analytical process.

8.7 It is recommended that the laboratory adopt additional quality-assurance practices for use with this method. The specific practices that would be most productive will depend upon the needs of the laboratory and the precision of the sampling technique. Whenever possible, the laboratory should perform analysis of standard reference materials and participate in relevant performance-evaluation studies.

8.8 Quality control for the analysis phase is very straightforward in as much as the instrument is a noncontact analyzer. That is, only the radiation emitted from the sample -- not the sample itself -- should touch the analyzer.

Because contamination of the system is not usually a problem (unless a sample spills on it), the most serious quality-control issues deal with uniform neutron flux, counting geometry, and spectral interpretation. The amount of radioactivity induced in a sample is directly proportional to the neutron flux it is exposed to. Because this flux can vary depending on how the sample is positioned in relation to the reactor core during irradiation, it is essential that a known standard be irradiated with every sample batch to act as a flux monitor. Care must also be taken to ensure that the standard and all samples associated with the standard are counted at the same distance from the detector.

9.0 METHOD PERFORMANCE

9.1 The following statistics are based on seven replicate analyses:

		<u>Chlorine</u>	<u>Bromine</u>	<u>Iodine</u>	<u>Combined average</u>	<u>Pooled</u>
River water	\bar{x}	38.2	17	<1	55.2	0.18
		0.16	0.076	---	---	0.18
Well water	\bar{x} (ppb)	50.7	4.7	<1	55.4	---
		0.30	0.038	---	55.2	0.30
WWTP effluent	\bar{x}	242	35.2	20.4	539.6	---
		0.56	0.033	0.23	---	0.61

9.2 The reliable limits of detection are 5 ppb for chlorine and 1 ppb for iodine and bromine.

10.0 REFERENCES

None required.

METHOD 9022
 TOTAL ORGANIC HALIDES (TOX) BY
 NEUTRON ACTIVATION ANALYSIS

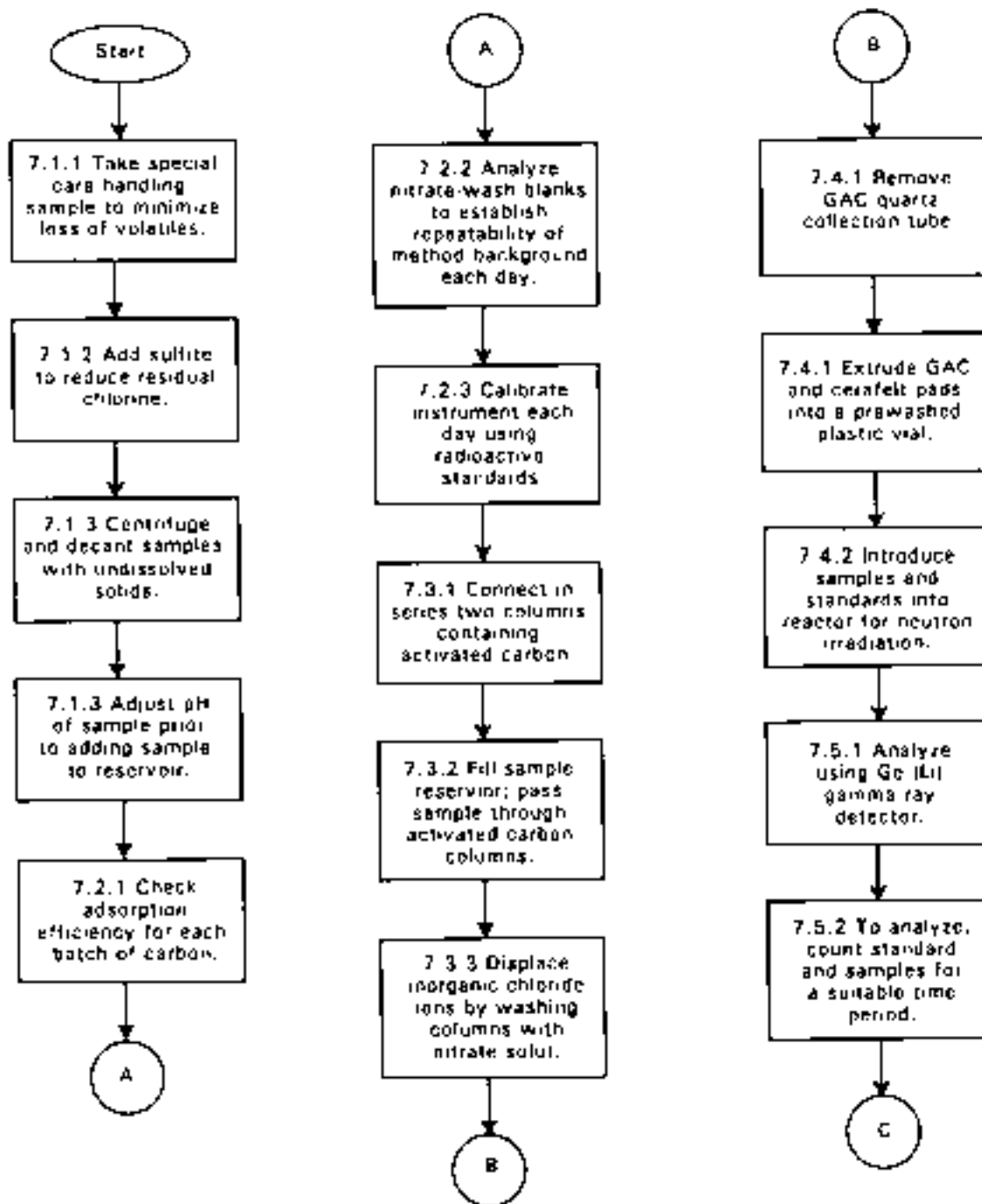

METHOD 9022
TOTAL ORGANIC HALIDES (TOX) BY
NEUTRON ACTIVATION ANALYSIS
(Continued)

