METHOD 1668

**Toxic Polychlorinated Biphenyls by Isotope Dilution High Resolution
Gas Chromatography/High Resolution Mass Spectrometry**

March 1997

**U.S. Environmental Protection Agency
Office of Water
Office of Science and Technology
Engineering and Analysis Division (4303)
401 M Street SW
Washington, DC 20460**

Acknowledgments

Method 1668 was prepared under the direction of William A. Telliard of the Engineering and Analysis Division within the EPA Office of Water (OW). This document was prepared under EPA Contract No. 68-C3-0337 by DynCorp Environmental, Energy & National Security Programs with assistance from its subcontractor Interface, Inc.

Disclaimer

This method has been reviewed by the Engineering and Analysis Division, U.S. Environmental Protection Agency, and approved for publication. Mention of trade names or commercial products does not constitute endorsement or recommendation for use.

Note: *This method is a draft based on preliminary validation in a single laboratory. In surveys of several laboratories using this method, EPA has found that it is normal for background levels of certain congeners that are found in high concentrations in PCBs to be present in the analytical systems in this method. Therefore, the concentrations of certain congeners in calibration and other solutions have been adjusted for these backgrounds. EPA welcomes constructive suggestions for improvement of this method.*

Introduction

Method 1668 was developed by the United States Environmental Protection Agency's Office of Science and Technology for congener-specific determination of the toxic co-planar and mono-ortho-substituted polychlorinated biphenyls (PCBs) in aqueous, solid, and tissue matrices by isotope dilution, high resolution capillary column gas chromatography (HRGC)/high resolution mass spectrometry (HRMS).

Questions and comments concerning this method or its application should be addressed to:

William A. Telliard, Director
Analytical Methods Staff (4303)
U.S. Environmental Protection Agency
401 M Street, SW
Washington, DC 20460
Phone: 202-260-7120
Fax: 202-260-7134

Method 1668

Toxic Polychlorinated Biphenyls by Isotope Dilution High Resolution Gas Chromatography/High Resolution Mass Spectrometry

1.0 Scope and Application

- 1.1 This method is for determination of the toxic polychlorinated biphenyls (PCBs) in water, soil, sediment, sludge, tissue, and other sample matrices by high resolution gas chromatography/high resolution mass spectrometry (HRGC/HRMS). The method is for use in EPA's data gathering and monitoring programs associated with the Clean Water Act, the Resource Conservation and Recovery Act, the Comprehensive Environmental Response, Compensation and Liability Act, and the Safe Drinking Water Act. The method is based on a compilation of methods from the technical literature (References 1-3) and on EPA Method 1613.
- 1.2 The toxic PCBs listed in Table 1 (Reference 4) and other specific congeners may be determined by this method.
- 1.3 The detection limits and quantitation levels in this method are usually dependent on the level of interferences rather than instrumental limitations. The minimum levels (MLs) in Table 2 are the levels at which the PCBs can be determined with only common laboratory interferences present. The Method Detection Limit (MDL) for PCB #126 has been determined as 40 pg/L (picograms/Liter; parts-per-quadrillion) in water using this method.
- 1.4 The GC/MS portions of this method are for use only by analysts experienced with HRGC/HRMS or under the close supervision of such qualified persons. Each laboratory that uses this method must demonstrate the ability to generate acceptable results using the procedure in Section 9.2.
- 1.5 This method is performance-based. The analyst is permitted to modify the method to overcome interferences or lower the cost of measurements, provided that all performance criteria in this method are met. The requirements for establishing method equivalency are given in Section 9.1.2.
- 1.6 Any modification of this method, beyond those expressly permitted, shall be considered a major modification subject to application and approval of alternate test procedures under 40 CFR Parts 136.4 and 136.5.

2.0 Summary of Method

Flow charts that summarize procedures for sample preparation, extraction, and analysis are given in Figure 1 for aqueous and solid samples, Figure 2 for multi-phase samples, and Figure 3 for tissue samples.

2.1 Extraction.

2.1.1 Aqueous samples (samples containing less than 1% solids)—Stable isotopically labeled analogs of the toxic PCBs are spiked into a 1-L sample, and the sample is vacuum-filtered through a glass-fiber filter on top of a solid-phase extraction (SPE) disk. Sample components on the filter and disk are eluted with methylene chloride and the eluant is concentrated for cleanup.

2.1.2 Solid, semi-solid, and multi-phase samples (but not tissue)—The labeled compounds are spiked into a sample containing 10 g (dry weight) of solids. Samples containing multiple phases are pressure filtered and any aqueous liquid is discarded. Coarse solids are ground or homogenized. Any non-aqueous liquid from multi-phase samples is combined with the solids and extracted in an SDS extractor. The extract is concentrated for cleanup.

2.1.3 Fish and other tissue—A 20-g aliquot of sample is homogenized, and a 10-g aliquot is spiked with the labeled compounds. The sample is mixed with sodium sulfate, allowed to dry for 12-24 hours, and extracted for 18-24 hours using methylene chloride:n-hexane (1:1) in a Soxhlet extractor. The extract is evaporated to dryness, and the lipid content is determined.

2.2 After extraction, samples are cleaned up using back-extraction with sulfuric acid and/or base, and gel permeation, silica gel, Florisil and activated carbon chromatography. High-performance liquid chromatography (HPLC) can be used for further isolation of specific isomers or congeners. Prior to the cleanup procedures cited above, tissue extracts are cleaned up using an anthropogenic isolation column.

2.3 After cleanup, the extract is concentrated to near dryness. Immediately prior to injection, internal standards are added to each extract, and an aliquot of the extract is injected into the gas chromatograph. The analytes are separated by the GC and detected by a high-resolution ($\geq 10,000$) mass spectrometer. Two exact m/z 's are monitored for each analyte.

2.4 An individual PCB congener is identified by comparing the GC retention time and ion-abundance ratio of two exact m/z 's with the corresponding retention time of an authentic standard and the theoretical or acquired ion-abundance ratio of the two exact m/z 's. Isomer specificity for the toxic PCBs is achieved using GC columns that resolve these congeners from the other PCBs.

2.5 Quantitative analysis is performed using selected ion current profile (SICP) areas in one of two ways:

2.5.1 For PCBs with labeled analogs (see Table 1), the GC/MS system is calibrated, and the concentration of each compound is determined using the isotope dilution technique.

2.5.2 For PCBs without labeled compounds, the GC/MS system is calibrated, and the concentration of each compound is determined using the internal standard technique.

2.6 The quality of the analysis is assured through reproducible calibration and testing of the extraction, cleanup, and GC/MS systems.

3.0 Definitions

Definitions are given in the glossary at the end of this method.

4.0 Contamination and Interferences

- 4.1** Solvents, reagents, glassware, and other sample processing hardware may yield artifacts and/or elevated baselines causing misinterpretation of chromatograms. Specific selection of reagents and purification of solvents by distillation in all-glass systems may be required. Where possible, reagents are cleaned by extraction or solvent rinse. The non-coplanar PCB congeners 105, 114, 118, 123, 156, 157, 167, and 180 have been shown to be very difficult to completely eliminate from the laboratory at the MDLs in this method, and baking of glassware in a kiln or furnace at 450-500 °C may be necessary to remove these and other contaminants.
- 4.2** Proper cleaning of glassware is extremely important because glassware may not only contaminate the samples but may also remove the analytes of interest by adsorption on the glass surface.
- 4.2.1** Glassware should be rinsed with solvent and washed with a detergent solution as soon after use as is practical. Sonication of glassware containing a detergent solution for approximately 30 seconds may aid in cleaning. Glassware with removable parts, particularly separatory funnels with fluoropolymer stopcocks, must be disassembled prior to detergent washing.
- 4.2.2** After detergent washing, glassware should be rinsed immediately; first with methanol, then with hot tap water. The tap water rinse is followed by another methanol rinse, then acetone, and then methylene chloride.
- 4.2.3** Baking of glassware in kiln or other high temperature furnace (450-500 °C) may be warranted after particularly dirty samples are encountered. However, baking should be minimized, as repeated baking of glassware may cause active sites on the glass surface that may irreversibly adsorb PCBs.
- 4.2.4** Immediately prior to use, the Soxhlet apparatus should be pre-extracted with toluene for approximately 3 hours (see Sections 12.3.1-12.3.3). The solid-phase extraction apparatus (Section 6.4.1.5) should be rinsed with methylene chloride/toluene (80/20 mixture).
- 4.3** All materials used in the analysis shall be demonstrated to be free from interferences by running reference matrix method blanks (Section 9.5) initially and with each sample batch (samples started through the extraction process on a given 12-hour shift to a maximum of 20 samples).
- 4.3.1** The reference matrix must simulate as closely as possible the sample matrix under test. Ideally, the reference matrix should not contain the PCBs in detectable amounts, but should contain potential interferents in the concentrations expected to be found in the samples to be analyzed.
- 4.3.2** When a reference matrix that simulates the sample matrix under test is not available, reagent water (Section 7.6.1) can be used to simulate water samples; playground sand (Section 7.6.2) or white quartz sand (Section 7.3.2) can be used to simulate soils; filter paper (Section 7.6.3) can be used to simulate papers and similar materials; and corn oil (Section 7.6.4) can be used to simulate tissues.
- 4.4** Interferences coextracted from samples will vary considerably from source to source, depending on the diversity of the site being sampled. Interfering compounds may be present at concentrations several orders of magnitude higher than the PCBs. The most frequently encountered interferences are chlorinated dioxins and dibenzofurans, methoxy biphenyls, hydroxydiphenyl ethers, benzylphenyl ethers, polynuclear aromatics, and pesticides. Because very low levels of PCBs are measured by this method, the elimination of interferences is essential. The cleanup steps given in

Section 13 can be used to reduce or eliminate these interferences and thereby permit reliable determination of the PCBs at the levels shown in Table 2.

- 4.5** Each piece of reusable glassware should be numbered to associate that glassware with the processing of a particular sample. This will assist the laboratory in tracking possible sources of contamination for individual samples, identifying glassware associated with highly contaminated samples that may require extra cleaning, and determining when glassware should be discarded.
- 4.6** Cleanup of tissue—The natural lipid content of tissue can interfere in the analysis of tissue samples for the PCBs. The lipid contents of different species and portions of tissue can vary widely. Lipids are soluble to varying degrees in various organic solvents and may be present in sufficient quantity to overwhelm the column chromatographic cleanup procedures used for cleanup of sample extracts. Lipids must be removed by the lipid removal procedures in Section 13.6, followed by Florisil (Section 13.7), and carbon (Section 13.4) as minimum additional cleanup steps.

5.0 Safety

- 5.1** The toxicity or carcinogenicity of each chemical used in this method has not been precisely determined; however, each compound should be treated as a potential health hazard. Exposure to these compounds should be reduced to the lowest possible level.
 - 5.1.1** The PCBs have been tentatively classified as known or suspected human or mammalian carcinogens. On the basis of the available toxicological and physical properties of the PCBs, pure standards should be handled only by highly trained personnel thoroughly familiar with handling and cautionary procedures and the associated risks.
 - 5.1.2** It is recommended that the laboratory purchase dilute standard solutions of the analytes in this method. However, if primary solutions are prepared, they shall be prepared in a hood, and a NIOSH/MESA approved toxic gas respirator shall be worn when high concentrations are handled.
- 5.2** The laboratory is responsible for maintaining a current awareness file of OSHA regulations regarding the safe handling of the chemicals specified in this method. A reference file of material safety data sheets (MSDSs) should also be made available to all personnel involved in these analyses. It is also suggested that the laboratory perform personal hygiene monitoring of each analyst who uses this method and that the results of this monitoring be made available to the analyst. Additional information on laboratory safety can be found in References 5-8. The references and bibliography at the end of Reference 8 are particularly comprehensive in dealing with the general subject of laboratory safety.
- 5.3** The pure PCBs and samples suspected to contain these compounds are handled using essentially the same techniques employed in handling radioactive or infectious materials. Well-ventilated, controlled access laboratories are required. Assistance in evaluating the health hazards of particular laboratory conditions may be obtained from certain consulting laboratories and from State Departments of Health or Labor, many of which have an industrial health service. Each laboratory must develop a strict safety program for handling these compounds. The practices in Reference 11 for handling chlorinated dibenzo-*p*-dioxins and dibenzofurans (CDDs/CDFs) are also recommended for handling the toxic PCBs.

- 5.3.1** Facility—When finely divided samples (dusts, soils, dry chemicals) are handled, all operations (including removal of samples from sample containers, weighing, transferring, and mixing) should be performed in a glove box demonstrated to be leak tight or in a fume hood demonstrated to have adequate air flow. Gross losses to the laboratory ventilation system must not be allowed. Handling of the dilute solutions normally used in analytical and animal work presents no inhalation hazards except in the case of an accident.
- 5.3.2** Protective equipment—Disposable plastic gloves, apron or lab coat, safety glasses or mask, and a glove box or fume hood adequate for radioactive work should be used. During analytical operations that may give rise to aerosols or dusts, personnel should wear respirators equipped with activated carbon filters. Eye protection equipment (preferably full face shields) must be worn while working with exposed samples or pure analytical standards. Latex gloves are commonly used to reduce exposure of the hands. When handling samples suspected or known to contain high concentrations of the PCBs, an additional set of gloves can also be worn beneath the latex gloves.
- 5.3.3** Training—Workers must be trained in the proper method of removing contaminated gloves and clothing without contacting the exterior surfaces.
- 5.3.4** Personal hygiene—Hands and forearms should be washed thoroughly after each manipulation and before breaks (coffee, lunch, and shift).
- 5.3.5** Confinement—Isolated work areas posted with signs, segregated glassware and tools, and plastic absorbent paper on bench tops will aid in confining contamination.
- 5.3.6** Effluent vapors—The effluents of sample splitters from the gas chromatograph (GC) and from roughing pumps on the mass spectrometer (MS) should pass through either a column of activated charcoal or be bubbled through a trap containing oil or high-boiling alcohols to condense PCB vapors.
- 5.3.7** Waste Handling—Good technique includes minimizing contaminated waste. Plastic bag liners should be used in waste cans. Janitors and other personnel must be trained in the safe handling of waste.
- 5.3.8** Decontamination.
- 5.3.8.1** Decontamination of personnel—Use any mild soap with plenty of scrubbing action.
- 5.3.8.2** Glassware, tools, and surfaces—Chlorothene NU Solvent is a less toxic solvent that should be effective in removing PCBs. Satisfactory cleaning may be accomplished by rinsing with Chlorothene, then washing with any detergent and water. If glassware is first rinsed with solvent, then the dish water may be disposed of in the sewer. Given the cost of disposal, it is prudent to minimize solvent wastes.
- 5.3.9** Laundry—Clothing known to be contaminated should be collected in plastic bags. Persons who convey the bags and launder the clothing should be advised of the hazard and trained in proper handling. The clothing may be put into a washer without contact if the launderer knows of the potential problem. The washer should be run through a cycle before being used again for other clothing.
- 5.3.10** Wipe tests—A useful method of determining cleanliness of work surfaces and tools is to wipe the surface with a piece of filter paper. Extraction and analysis by GC with an electron capture detector (ECD) can achieve a limit of detection of 0.1 g per wipe; analysis using this

method can achieve an even lower detection limit. Less than 0.1 µg per wipe indicates acceptable cleanliness; anything higher warrants further cleaning. More than 10 µg on a wipe constitutes an acute hazard and requires prompt cleaning before further use of the equipment or work space, and indicates that unacceptable work practices have been employed.

6.0 Apparatus, Equipment and Supplies

Note: *Brand names, suppliers, and part numbers are for illustration purposes only and no endorsement is implied. Equivalent performance may be achieved using apparatus and materials other than those specified here. Meeting the performance requirements of this method is the responsibility of the laboratory.*

6.1 Sampling equipment for discrete or composite sampling.

6.1.1 Sample bottles and caps.

6.1.1.1 Liquid samples (waters, sludges and similar materials containing 5% solids or less)—Sample bottle, amber glass, 1.1-L minimum, with screw cap.

6.1.1.2 Solid samples (soils, sediments, sludges, paper pulps, filter cake, compost, and similar materials that contain more than 5% solids)—Sample bottle, wide mouth, amber glass, 500-mL minimum.

6.1.1.3 If amber bottles are not available, samples shall be protected from light.

6.1.1.4 Bottle caps—Threaded to fit sample bottles. Caps shall be lined with fluoropolymer.

6.1.1.5 Cleaning.

6.1.1.5.1 Bottles are detergent water washed, then solvent rinsed before use.

6.1.1.5.2 Liners are detergent water washed and rinsed with reagent water (Section 7.6.1).

6.1.2 Compositing equipment—Automatic or manual compositing system incorporating glass containers cleaned per bottle cleaning procedure above. Only glass or fluoropolymer tubing shall be used. If the sampler uses a peristaltic pump, a minimum length of compressible silicone rubber tubing may be used in the pump only. Before use, the tubing shall be thoroughly rinsed with methanol, followed by repeated rinsing with reagent water to minimize sample contamination. An integrating flow meter is used to collect proportional composite samples.

6.2 Equipment for glassware cleaning—Laboratory sink with overhead fume hood.

6.3 Equipment for sample preparation.

6.3.1 Laboratory fume hood of sufficient size to contain the sample preparation equipment listed below.

6.3.2 Glove box (optional).

6.3.3 Tissue homogenizer—VirTis Model 45 Macro homogenizer (American Scientific Products H-3515, or equivalent) with stainless steel Macro-shaft and Turbo-shear blade.

6.3.4 Meat grinder—Hobart, or equivalent, with 3- to 5-mm holes in inner plate.

-
- 6.3.5** Equipment for determining percent moisture.
 - 6.3.5.1** Oven—Capable of maintaining a temperature of $110 \pm 5^\circ\text{C}$.
 - 6.3.5.2** Desiccator.
 - 6.3.6** Balances.
 - 6.3.6.1** Analytical—Capable of weighing 0.1 mg.
 - 6.3.6.2** Top loading—Capable of weighing 10 mg.
 - 6.4** Extraction apparatus.
 - 6.4.1** Water samples.
 - 6.4.1.1** pH meter, with combination glass electrode.
 - 6.4.1.2** pH paper, wide range (Hydrion Papers, or equivalent).
 - 6.4.1.3** Graduated cylinder, 1-L capacity.
 - 6.4.1.4** Liquid/liquid extraction—Separatory funnels, 250-, 500-, and 2000-mL, with fluoropolymer stopcocks.
 - 6.4.1.5** Solid-phase extraction.
 - 6.4.1.5.1** 1-L filtration apparatus, including glass funnel, frit support, clamp, adapter, stopper, filtration flask, and vacuum tubing (Figure 4). For wastewater samples, the apparatus should accept 90 or 144 mm disks. For drinking water or other samples containing low solids, smaller disks may be used.
 - 6.4.1.5.2** Vacuum source capable of maintaining 25 in. Hg, equipped with shutoff valve and vacuum gauge.
 - 6.4.1.5.3** Glass-fiber filter—Whatman GMF 150 (or equivalent), 1 micron pore size, to fit filtration apparatus in Section 6.4.1.5.1.
 - 6.4.1.5.4** Solid-phase extraction disk containing octadecyl (C_{18}) bonded silica uniformly enmeshed in an inert matrix—Fisher Scientific 14-378F (or equivalent), to fit filtration apparatus in Section 6.4.1.5.1.
 - 6.4.2** Soxhlet/Dean-Stark (SDS) extractor (Figure 5 and Reference 12) for filters and solid/sludge samples.
 - 6.4.2.1** Soxhlet—50-mm ID, 200-mL capacity with 500-mL flask (Cal-Glass LG-6900, or equivalent, except substitute 500-mL round-bottom flask for 300-mL flat-bottom flask).
 - 6.4.2.2** Thimble— 43×123 to fit Soxhlet (Cal-Glass LG-6901-122, or equivalent).
 - 6.4.2.3** Moisture trap—Dean Stark or Barret with fluoropolymer stopcock, to fit Soxhlet.
 - 6.4.2.4** Heating mantle—Hemispherical, to fit 500-mL round-bottom flask (Cal-Glass LG-8801-112, or equivalent).
 - 6.4.2.5** Variable transformer—Powerstat (or equivalent), 110-volt, 10-amp.
 - 6.4.3** Beakers—400- to 500-mL.
 - 6.4.4** Spatulas—Stainless steel.
 - 6.5** Filtration apparatus.
 - 6.5.1** Pyrex glass wool—Solvent-extracted by SDS for 3 hours minimum.

- 6.5.2** Glass funnel—125- to 250-mL.
- 6.5.3** Glass-fiber filter paper—Whatman GF/D (or equivalent), to fit glass funnel in Section 6.5.2.
- 6.5.4** Drying column—15- to 20-mm ID Pyrex chromatographic column equipped with coarse-glass frit or glass-wool plug.
- 6.5.5** Buchner funnel—15-cm.
- 6.5.6** Glass-fiber filter paper for Buchner funnel above.
- 6.5.7** Filtration flasks—1.5- to 2.0-L, with side arm.
- 6.5.8** Pressure filtration apparatus—Millipore YT30 142 HW, or equivalent.
- 6.6** Centrifuge apparatus.
 - 6.6.1** Centrifuge—Capable of rotating 500-mL centrifuge bottles or 15-mL centrifuge tubes at 5,000 rpm minimum.
 - 6.6.2** Centrifuge bottles—500-mL, with screw-caps, to fit centrifuge.
 - 6.6.3** Centrifuge tubes—12- to 15-mL, with screw-caps, to fit centrifuge.
- 6.7** Cleanup apparatus.
 - 6.7.1** Automated gel permeation chromatograph (Analytical Biochemical Labs, Inc, Columbia, MO, Model GPC Autoprep 1002, or equivalent).
 - 6.7.1.1** Column—600-700 mm long \times 25 mm ID, packed with 70 g of SX-3 Bio-beads (Bio-Rad Laboratories, Richmond, CA, or equivalent).
 - 6.7.1.2** Syringe—10-mL, with Luer fitting.
 - 6.7.1.3** Syringe filter holder—stainless steel, and glass- fiber or fluoropolymer filters (Gelman 4310, or equivalent).
 - 6.7.1.4** UV detectors—254-nm, preparative or semi-preparative flow cell (Isco, Inc., Type 6; Schmadzu, 5-mm path length; Beckman-Altex 152W, 8- μ L micro-prep flow cell, 2-mm path; Pharmacia UV-1, 3-mm flow cell; LDC Milton-Roy UV-3, monitor #1203; or equivalent).
 - 6.7.2** Reverse-phase high-performance liquid chromatograph.
 - 6.7.2.1** Column oven and detector—Perkin-Elmer Model LC-65T (or equivalent) operated at 0.02 AUFS at 235 nm.
 - 6.7.2.2** Injector—Rheodyne 7120 (or equivalent) with 50- μ L sample loop.
 - 6.7.2.3** Column—Two 6.2 mm \times 250 mm Zorbax-ODS columns in series (DuPont Instruments Division, Wilmington, DE, or equivalent), operated at 30°C and 2.0 mL/min with gradient from TBD percent methanol:acetonitrile to 100 percent acetonitrile in TBD minutes.
 - 6.7.2.4** Pump—Altex 110A (or equivalent).
 - 6.7.3** Pipets.
 - 6.7.3.1** Disposable, Pasteur, 150-mm long \times 5-mm ID (Fisher Scientific 13-678-6A, or equivalent).
 - 6.7.3.2** Disposable, serological, 50-mL (8- to 10- mm ID).

- 6.7.4** Glass chromatographic columns.
- 6.7.4.1** 150-mm long × 8-mm ID, (Kontes K-420155, or equivalent) with coarse-glass frit or glass-wool plug and 250-mL reservoir.
 - 6.7.4.2** 200-mm long × 15-mm ID, with coarse-glass frit or glass-wool plug and 250-mL reservoir.
 - 6.7.4.3** 300-mm long × 22-mm ID, with coarse-glass frit, 300-mL reservoir, and glass or fluoropolymer stopcock.
- 6.7.5** Stirring apparatus for batch silica cleanup of tissue extracts.
- 6.7.5.1** Mechanical stirrer—Corning Model 320, or equivalent.
 - 6.7.5.2** Bottle—500- to 600-mL wide-mouth clear glass.
- 6.7.6** Oven—For baking and storage of adsorbents, capable of maintaining a constant temperature ($\pm 5^{\circ}\text{C}$) in the range of 105-250°C.
- 6.8** Concentration apparatus.
- 6.8.1** Rotary evaporator—Buchi/Brinkman-American Scientific No. E5045-10 or equivalent, equipped with a variable temperature water bath.
- 6.8.1.1** Vacuum source for rotary evaporator equipped with shutoff valve at the evaporator and vacuum gauge.
 - 6.8.1.2** A recirculating water pump and chiller are recommended, as use of tap water for cooling the evaporator wastes large volumes of water and can lead to inconsistent performance as water temperatures and pressures vary.
 - 6.8.1.3** Round-bottom flask—100-mL and 500-mL or larger, with ground-glass fitting compatible with the rotary evaporator.
- 6.8.2** Kuderna-Danish (K-D) concentrator.
- 6.8.2.1** Concentrator tube—10-mL, graduated (Kontes K-570050-1025, or equivalent) with calibration verified. Ground-glass stopper (size 19/22 joint) is used to prevent evaporation of extracts.
 - 6.8.2.2** Evaporation flask—500-mL (Kontes K-570001-0500, or equivalent), attached to concentrator tube with springs (Kontes K-662750-0012 or equivalent).
 - 6.8.2.3** Snyder column—Three-ball macro (Kontes K-503000-0232, or equivalent).
 - 6.8.2.4** Boiling chips.
 - 6.8.2.4.1** Glass or silicon carbide—Approximately 10/40 mesh, extracted with methylene chloride and baked at 450°C for 1 hour minimum.
 - 6.8.2.4.2** Fluoropolymer (optional)—Extracted with methylene chloride.
 - 6.8.2.5** Water bath—Heated, with concentric ring cover, capable of maintaining a temperature within $\pm 2^{\circ}\text{C}$, installed in a fume hood.
- 6.8.3** Nitrogen blowdown apparatus—Equipped with water bath controlled in the range of 30 - 60°C (N-Evap, Organomation Associates, Inc., South Berlin, MA, or equivalent), installed in a fume hood.

6.8.4 Sample vials.

6.8.4.1 Amber glass, 2- to 5-mL with fluoropolymer-lined screw-cap.

6.8.4.2 Glass, 0.3-mL, conical, with fluoropolymer-lined screw or crimp cap.

6.9 Gas chromatograph—Shall have splitless or on-column injection port for capillary column, temperature program with isothermal hold, and shall meet all of the performance specifications in Section 10.

6.9.1 GC columns—The pair of GC columns listed below are capable of resolving all 209 PCB congeners. Other GC columns may be used so long as PCBs 126 and 169 are each resolved from their respective most closely eluted leading and trailing congeners. The valley height between PCB 126 or 169 and its respective most closely eluted leading and trailing congeners must be less than 10 percent of the height of the shorter of the pair.

6.9.2 Column #1—30±5-m long × 0.25±0.02-mm ID; 0.25-µm film SPB-Octyl (Supelco 2-4218, or equivalent).

6.9.3 Column #2—30±5-m long × 0.25±0.02-mm ID; 0.25-µm film DB-1 (J&W, or equivalent).

6.10 Mass spectrometer—28- to 40-eV electron impact ionization, shall be capable of repetitively selectively monitoring 12 exact m/z's minimum at high resolution (≥10,000) during a period less than 1.5 seconds, and shall meet all of the performance specifications in Section 10.

6.11 GC/MS interface—The mass spectrometer (MS) shall be interfaced to the GC such that the end of the capillary column terminates within 1 cm of the ion source but does not intercept the electron or ion beams.

6.12 Data system—Capable of collecting, recording, and storing MS data.

7.0 Reagents and Standards

7.1 pH adjustment and back-extraction.

7.1.1 Potassium hydroxide—Dissolve 20 g reagent grade KOH in 100 mL reagent water.

7.1.2 Sulfuric acid—Reagent grade (specific gravity 1.84).

7.1.3 Hydrochloric acid—Reagent grade, 6N.

7.1.4 Sodium chloride—Reagent grade, prepare at 5% (w/v) solution in reagent water.

7.2 Solution drying and evaporation.

7.2.1 Solution drying—Sodium sulfate, reagent grade, granular, anhydrous (Baker 3375, or equivalent), rinsed with methylene chloride (20 mL/g), baked at 400°C for 1 hour minimum, cooled in a desiccator, and stored in a pre-cleaned glass bottle with screw-cap that prevents moisture from entering. If, after heating, the sodium sulfate develops a noticeable grayish cast (due to the presence of carbon in the crystal matrix), that batch of reagent is not suitable for use and should be discarded. Extraction with methylene chloride (as opposed to simple rinsing) and baking at a lower temperature may produce sodium sulfate that is suitable for use.

7.2.2 Tissue drying—Sodium sulfate, reagent grade, powdered, treated and stored as above.

7.2.3 Prepurified nitrogen.

7.3 Extraction.

7.3.1 Solvents—Acetone, toluene, n-hexane, methanol, methylene chloride, and nonane; distilled in glass, pesticide quality, lot-certified to be free of interferences.

7.3.2 White quartz sand, 60/70 mesh—For Soxhlet/Dean-Stark extraction (Aldrich Chemical, Cat. No. 27-437-9, or equivalent). Bake at 450°C for 4 hours minimum.

7.4 GPC calibration solution—Prepare a solution containing 300 mg/mL corn oil, TBD mg/mL PCB 209, 1.4 mg/mL pentachlorophenol, 0.1 mg/mL perylene, and 0.5 mg/mL sulfur. [To be modified if necessary.]

7.5 Adsorbents for sample cleanup.**7.5.1** Silica gel.

7.5.1.1 Activated silica gel—100-200 mesh, Supelco 1-3651 (or equivalent), rinsed with methylene chloride, baked at 180°C for a minimum of 1 hour, cooled in a desiccator, and stored in a precleaned glass bottle with screw-cap that prevents moisture from entering.

7.5.1.2 Acid silica gel (30% w/w)—Thoroughly mix 44.0 g of concentrated sulfuric acid with 100.0 g of activated silica gel in a clean container. Break up aggregates with a stirring rod until a uniform mixture is obtained. Store in a screw-capped bottle with fluoropolymer-lined cap.

7.5.1.3 Basic silica gel—Thoroughly mix 30 g of 1N sodium hydroxide with 100 g of activated silica gel in a clean container. Break up aggregates with a stirring rod until a uniform mixture is obtained. Store in a screw-capped bottle with fluoropolymer-lined cap.

7.5.1.4 Potassium silicate.

7.5.1.4.1 Dissolve 56 g of high purity potassium hydroxide (Aldrich, or equivalent) in 300 mL of methanol in a 750- to 1000-mL flat-bottom flask.

7.5.1.4.2 Add 100 g of activated silica gel (Section 7.5.1.1) and a stirring bar, and stir on a hot plate at 60-70°C for 1-2 hours.

7.5.1.4.3 Decant the liquid and rinse the potassium silicate twice with 100-mL portions of methanol, followed by a single rinse with 100 mL of methylene chloride.

7.5.1.4.4 Spread the potassium silicate on solvent-rinsed aluminum foil and dry for 2-4 hours in a hood.

7.5.1.4.5 Activate overnight at 200-250°C.

7.5.2 Carbon.

7.5.2.1 Carbopak C—(Supelco 1-0258, or equivalent).

7.5.2.2 Celite 545—(Supelco 2-0199, or equivalent).

7.5.2.3 Thoroughly mix 18.0 g Carbopak C and 18.0 g Celite 545 to produce a 50% w/w mixture. Activate the mixture at 130°C for a minimum of 6 hours. Store in a desiccator.

7.5.3 Anthropogenic isolation column—Pack the column in Section 6.7.4.3 from bottom to top with the following:

7.5.3.1 2 g activated silica gel (Section 7.5.1.1).

- 7.5.3.2** 2 g potassium silicate (Section 7.5.1.4).
- 7.5.3.3** 2 g granular anhydrous sodium sulfate (Section 7.2.1).
- 7.5.3.4** 10 g acid silica gel (Section 7.5.1.2).
- 7.5.3.5** 2 g granular anhydrous sodium sulfate.
- 7.5.4** Florisil column.
 - 7.5.4.1** Florisil—PR grade, 60-100 mesh (U.S. Silica Corp, Berkeley Springs, WV, or equivalent). Fill a clean 1- to 2-L bottle 1/2 to 2/3 full with Florisil and place in an oven at 130-150 °C for a minimum of three days.
 - 7.5.4.2** Immediately prior to use, dry pack a 300-mm x 22-mm ID glass column (Section 6.7.4.3) bottom to top with 0.5-1.0 cm of anhydrous sodium sulfate (Section 7.2.1), 10-10.5 cm of warm to hot activated Florisil (Section 7.5.4.1), and 1-2 cm of warm to hot anhydrous sodium sulfate. Allow the column to cool and wet immediately with 100 mL of n-hexane to prevent water from entering.
 - 7.5.4.3** Using the procedure in Section 13.7, establish the elution pattern for each carton of Florisil received.
- 7.6** Reference matrices—Matrices in which the PCBs and interfering compounds are not detected by this method.
 - 7.6.1** Reagent water—Bottled water purchased locally or prepared by passage through activated carbon.
 - 7.6.2** High-solids reference matrix—Playground sand or similar material. Prepared by extraction with methylene chloride and/or baking at 450°C for a minimum of 4 hours.
 - 7.6.3** Paper reference matrix—Glass-fiber filter, Gelman type A, or equivalent. Cut paper to simulate the surface area of the paper sample being tested.
 - 7.6.4** Tissue reference matrix—Corn or other vegetable oil. May be prepared by extraction with methylene chloride.
 - 7.6.5** Other matrices—This method may be verified on any reference matrix by performing the tests given in Section 9.2. Ideally, the matrix should be free of the PCBs, but in no case shall the background level of the PCBs in the reference matrix exceed three times the minimum levels in Table 2. If low background levels of the PCBs are present in the reference matrix, the spike level of the analytes used in Section 9.2 should be increased to provide a spike-to-background ratio in the range of 1:1 to 5:1 (Reference 11).
- 7.7** Standard solutions—Purchased as solutions or mixtures with certification to their purity, concentration, and authenticity, or prepared from materials of known purity and composition. If the chemical purity is 98% or greater, the weight may be used without correction to compute the concentration of the standard. When not being used, standards are stored in the dark at room temperature in screw-capped vials with fluoropolymer-lined caps. A mark is placed on the vial at the level of the solution so that solvent loss by evaporation can be detected. If solvent loss has occurred, the solution should be replaced.

7.8 Stock solutions.

- 7.8.1** Preparation—Prepare in nonane per the steps below or purchase as dilute solutions (Cambridge Isotope Laboratories (CIL), Woburn, MA, or equivalent). Observe the safety precautions in Section 5 and the recommendation in Section 5.1.2.
- 7.8.2** Dissolve an appropriate amount of assayed reference material in solvent. For example, weigh 1 to 2 mg of PCB 126 to three significant figures in a 10-mL ground-glass-stoppered volumetric flask and fill to the mark with nonane. After the PCB is completely dissolved, transfer the solution to a clean 15-mL vial with fluoropolymer-lined cap.
- 7.8.3** Stock standard solutions should be checked for signs of degradation prior to the preparation of calibration or performance test standards. Reference standards that can be used to determine the accuracy of calibration standards are available from several vendors.

7.9 PAR stock solution.

- 7.9.1** All PCBs—Using the solutions in Section 7.8, prepare the PAR stock solution to contain the PCBs of interest at the concentrations shown in Table 3. When diluted, the solution will become the PAR (Section 7.14).
- 7.9.2** If the toxic, non-ortho, co-planar PCBs (PCBs 77, 126, and 169) only are to be determined, prepare the PAR stock solution to contain these compounds only.

7.10 Labeled-compound spiking solution.

- 7.10.1** All toxic PCBs—From stock solutions, or from purchased mixtures, prepare this solution to contain the labeled compounds in nonane at the concentrations shown in Table 3. This solution is diluted with acetone prior to use (Section 7.10.3).
- 7.10.2** If PCBs 77, 126, and 169 only are to be determined, prepare the labeled-compound solution to contain these compounds only. This solution is diluted with acetone prior to use (Section 7.10.3).
- 7.10.3** Dilute a sufficient volume of the labeled compound solution (Section 7.10.1 or 7.10.2) by a factor of 500 with acetone to prepare a diluted spiking solution. Each sample requires 1.0 mL of the diluted solution, but no more solution should be prepared than can be used in one day.

7.11 Cleanup standard—Prepare PCBs 81 and 111 in nonane at the concentration shown in Table 3. The cleanup standard is added to all extracts prior to cleanup to measure the efficiency of the cleanup process.

7.12 Internal standard(s).

- 7.12.1** All toxic PCBs—Prepare the internal standard solution to contain labeled PCBs 52, 101, 138, and 178 in nonane at the concentration shown in Table 3.
- 7.12.2** If PCBs 77, 126, and 169 only are to be determined, the internal standard solution may be prepared to contain PCBs 52, 101, and 138 only.

7.13 Calibration standards (CS1 through CS5)—Combine the solutions in Sections 7.9-7.12 to produce the five calibration solutions shown in Table 4 in nonane. These solutions permit the relative response (labeled to native) and response factor to be measured as a function of concentration. The CS3 standard is used for calibration verification (VER). If the PCBs 77, 126, and 169 only are to be determined, combine the solutions appropriate to these compounds.

- 7.14** Precision and recovery (PAR) standard—Used for determination of initial (Section 9.2) and ongoing (Section 15.5) precision and recovery (See Table 3). Dilute 200 µL of the PAR stock solution (Section 7.9.1 or 7.9.2) to 10 mL with acetone for each sample matrix for each sample batch. One mL of each are required for the blank and OPR with each matrix in each batch.
- 7.15** GC retention time window defining solution and isomer specificity test standard—Used to define the beginning and ending retention times for the PCB congeners and to demonstrate isomer specificity of the GC columns employed for determination of PCB 126. The standard must contain the compounds listed in Table 5 (CIL , or equivalent), at a minimum. It is not necessary to monitor all of the window-defining compounds if PCBs 77, 126, and 169 only are to be determined. In this case, a congener-specificity test standard containing the most closely eluted isomers listed in Table 5 (CIL , or equivalent) may be used.
- 7.16** QC Check Sample—A QC Check Sample should be obtained from a source independent of the calibration standards. Ideally, this check sample would be a certified standard reference material (SRM) containing the PCBs in known concentrations in a sample matrix similar to the matrix being analyzed. The National Institute of Standards and Technology (NIST) in Gaithersburg, Maryland has SRMs for several individual PCB congeners, and as Aroclors in transformer and motor oil, in combination with pesticides in cod liver oil, and in combination with 2,3,7,8-TCDD in human serum.
- 7.17** Stability of solutions—Standard solutions used for quantitative purposes (Sections 7.9 through 7.15) should be analyzed periodically, and should be assayed against reference standards before further use.

8.0 Sample Collection, Preservation, Storage, and Holding Times.

- 8.1** Collect samples in amber glass containers following conventional sampling practices (Reference 12).
- 8.2** Aqueous samples.
- 8.2.1** Samples that flow freely are collected as grab samples or in refrigerated bottles using automatic sampling equipment.
- 8.2.2** If residual chlorine is present, add 80 mg sodium thiosulfate per liter of water. EPA Methods 330.4 and 330.5 may be used to measure residual chlorine (Reference 13).
- 8.2.3** Adjust sample pH 2-3 with sulfuric acid.
- 8.2.4** Maintain aqueous samples in the dark at 0-4°C from the time of collection until receipt at the laboratory. Store in the dark at 0-4°C.
- 8.3** Solid samples.
- 8.3.4** Solid samples are collected as grab samples using wide-mouth jars.
- 8.3.4** Maintain solid, semi-solid, oily, and mixed-phase samples in the dark at <4°C from the time of collection until receipt at the laboratory. Store solid, semi-solid, oily, and mixed-phase samples in the dark at <-10°C.
- 8.4** Fish and tissue samples.

- 8.4.1 Fish may be cleaned, filleted, or processed in other ways in the field, such that the laboratory may expect to receive whole fish, fish fillets, or other tissues for analysis.
- 8.4.2 Fish collected in the field should be wrapped in aluminum foil and must be maintained at a temperature less than 4°C from the time of collection until receipt at the laboratory.
- 8.4.3 Samples must be frozen upon receipt at the laboratory and maintained in the dark at <-10°C until prepared. Maintain unused sample in the dark at <-10°C.

8.5 Holding times.

- 8.5.1 There are no demonstrated maximum holding times associated with the PCBs in aqueous, solid, semi-solid, tissues, or other sample matrices. If stored in the dark at 0-4°C and preserved as given above (if required), aqueous samples may be stored for up to one year. Similarly, if stored in the dark at <-10°C, solid, semi-solid, multi-phase, and tissue samples may be stored for up to one year.
- 8.5.2 Store sample extracts in the dark at <-10°C until analyzed. If stored in the dark at <-10°C, sample extracts may be stored for up to one year.

9.0 Quality Assurance/Quality Control

- 9.1 Each laboratory that uses this method is required to operate a formal quality assurance program (Reference 14). The minimum requirements of this program consist of an initial demonstration of laboratory capability, analysis of samples spiked with labeled compounds to evaluate and document data quality, and analysis of standards and blanks as tests of continued performance. Laboratory performance is compared to established performance criteria to determine if the results of analyses meet the performance characteristics of the method.

If the method is to be applied to a sample matrix other than water (e.g., soils, filter cake, compost, tissue) the most appropriate alternate matrix (Sections 7.6.2-7.6.5 and 7.16) is substituted for the reagent water matrix (Section 7.6.1) in all performance tests.

- 9.1.1 The analyst shall make an initial demonstration of the ability to generate acceptable accuracy and precision with this method. This ability is established as described in Section 9.2.
- 9.1.2 In recognition of advances that are occurring in analytical technology and to allow the analyst to overcome sample matrix interferences, the analyst is permitted certain options to improve separations or lower the costs of measurements. These options include alternate extraction, concentration, cleanup procedures, and changes in columns and detectors. Alternate determinative techniques, such as the substitution of spectroscopic or immuno-assay techniques, and changes that degrade method performance, are not allowed. If an analytical technique other than the techniques specified in this method is used, that technique must have a specificity equal to or better than the specificity of the techniques in this method for the analytes of interest.
 - 9.1.2.1 Each time a modification is made to this method, the analyst is required to repeat the procedure in Section 9.2. If the detection limit of the method will be affected by the change, the laboratory is required to demonstrate that the MDL (40 CFR Part 136, Appendix B) is lower than one-third the regulatory compliance level or one-third the ML in this method, whichever is higher. If calibration will be affected by the change, the analyst must recalibrate the instrument per Section 10.

- 9.1.2.2** The laboratory is required to maintain records of modifications made to this method. These records include the following at a minimum:
- 9.1.2.2.1** The names, titles, addresses, and telephone numbers of the analyst(s) who performed the analyses and modification, and of the quality control officer who witnessed and will verify the analyses and modifications.
 - 9.1.2.2.2** A listing of pollutant(s) measured, by name and CAS Registry number.
 - 9.1.2.2.3** A narrative stating reason(s) for the modifications.
 - 9.1.2.2.4** Results from all quality control (QC) tests comparing the modified method to this method. These results are to include the following:
 - a) Calibration (Section 10.5-10.7).
 - b) Calibration verification (Section 15.3).
 - c) Initial precision and recovery (Section 9.2).
 - d) Labeled compound recovery (Section 9.3).
 - e) Analysis of blanks (Section 9.5).
 - f) Accuracy assessment (Section 9.4).
 - 9.1.2.2.5** Data that will allow an independent reviewer to validate each determination by tracing the instrument output (peak height, area, or other signal) to the final result. These data are to include the following:
 - a) Sample numbers and other identifiers.
 - b) Extraction dates.
 - c) Analysis dates and times.
 - d) Analysis sequence/run chronology.
 - e) Sample weight or volume (Section 11).
 - f) Extract volume prior to each cleanup step (Section 13).
 - g) Extract volume after each cleanup step (Section 13).
 - h) Final extract volume prior to injection (Section 14).
 - i) Injection volume (Section 14.3).
 - j) Dilution data, differentiating between dilution of a sample or extract (Section 17.5).
 - k) Instrument and operating conditions.
 - l) Column (dimensions, liquid phase, solid support, film thickness, etc).
 - m) Operating conditions (temperatures, temperature program, flow rates).
 - n) Detector (type, operating conditions, etc).
 - o) Chromatograms, printer tapes, and other recordings of raw data.
 - p) Quantitation reports, data system outputs, and other data to link the raw data to the results reported.
- 9.1.3** Analyses of method blanks are required to demonstrate freedom from contamination (Section 4.3). The procedures and criteria for analysis of a method blank are described in Sections 9.5 and 15.6.
- 9.1.4** The laboratory shall spike all samples with labeled compounds to monitor method performance. This test is described in Section 9.3. When results of these spikes indicate atypical method performance for samples, the samples are diluted to bring method performance within acceptable limits. Procedures for dilution are given in Section 17.5.

-
- 9.1.5** The laboratory shall, on an ongoing basis, demonstrate through calibration verification and the analysis of the ongoing precision and recovery aliquot that the analytical system is in control. These procedures are described in Sections 15.1 through 15.5.
- 9.1.6** The laboratory shall maintain records to define the quality of data that is generated. Development of accuracy statements is described in Section 9.4.
- 9.2** Initial precision and recovery (IPR)—To establish the ability to generate acceptable precision and recovery, the analyst shall perform the following operations.
- 9.2.1** For low solids (aqueous, < 1% solids) samples, extract, concentrate, and analyze four 1-L aliquots of reagent water spiked with the diluted labeled compound spiking solution (Section 7.10.3) and the precision and recovery standard (Section 7.14) according to the procedures in Sections 11 through 18. For an alternative sample matrix, four aliquots of the alternative reference matrix (Section 7.6) are used. All sample processing steps that are to be used for processing samples, including preparation (Section 11), extraction (Section 12), and cleanup (Section 13), shall be included in this test.
- 9.2.2** Using results of the set of four analyses, compute the average concentration (\bar{X}) of the extracts in ng/mL and the standard deviation of the concentration (s) in ng/mL for each compound, by isotope dilution for PCBs with a labeled analog, and by internal standard for the PCBs without a labeled analog, and the labeled compounds.
- 9.2.3** For each PCB and labeled compound, compare s and \bar{X} with the corresponding limits for initial precision and recovery in Table 6. If PCBs 77, 126, and 169 only are to be determined, compare s and \bar{X} with the corresponding limits for initial precision and recovery in Table 6a. If s and \bar{X} for all compounds meet the acceptance criteria, system performance is acceptable and analysis of blanks and samples may begin. If, however, any individual s exceeds the precision limit or any individual \bar{X} falls outside the range for accuracy, system performance is unacceptable for that compound. Correct the problem and repeat the test (Section 9.2).
- 9.3** The laboratory shall spike all samples with the diluted labeled compound spiking solution (Section 7.10.3) to assess method performance on the sample matrix.
- 9.3.1** Analyze each sample according to the procedures in Sections 11 through 18.
- 9.3.2** Compute the percent recovery of the labeled compounds and the cleanup standard using the internal standard method (Section 17.2).
- 9.3.3** The recovery of each labeled compound must be within the limits in Table 7 when all of the toxic PCBs are determined, and within the limits in Table 7a when PCBs 77, 126, and 169 only are determined. If the recovery of any compound falls outside of these limits, method performance is unacceptable for that compound in that sample. Additional cleanup procedures must then be employed to attempt to bring the recovery within the normal range. If the recovery cannot be brought within the normal range after all cleanup procedures have been employed, water samples are diluted and smaller amounts of soils, sludges, sediments, and other matrices are analyzed per Section 18.4.

- 9.4** Recovery of labeled compounds from samples should be assessed and records should be maintained.
- 9.4.1** After the analysis of five samples of a given matrix type (water, soil, sludge, pulp, etc.) for which the labeled compounds pass the tests in Section 9.3, compute the average percent recovery (R) and the standard deviation of the percent recovery (S_R) for the labeled compounds only. Express the assessment as a percent recovery interval from $R - 2S_R$ to $R + 2S_R$ for each matrix. For example, if $R = 90\%$ and $S_R = 10\%$ for five analyses of pulp, the recovery interval is expressed as 70 to 110%.
- 9.4.2** Update the accuracy assessment for each labeled compound in each matrix on a regular basis (e.g., after each five to ten new measurements).
- 9.5** Method blanks—Reference matrix method blanks are analyzed to demonstrate freedom from contamination (Section 4.3).
- 9.5.1** Prepare, extract, clean up, and concentrate a method blank with each sample batch (samples of the same matrix started through the extraction process on the same 12-hour shift, to a maximum of 20 samples). The matrix for the method blank shall be similar to sample matrix for the batch; e.g., a 1-L reagent water blank (Section 7.6.1), high-solids reference matrix blank (Section 7.6.2), paper matrix blank (Section 7.6.3), tissue blank (Section 7.6.4), or alternative reference matrix blank (Section 7.6.5). Analyze the blank immediately after analysis of the OPR (Section 15.5) to demonstrate freedom from contamination.
- 9.5.2** If any PCB (Table 1) is found in the blank at greater than the minimum level (Table 2) or one-third the regulatory compliance level whichever is greater, or if any potentially interfering compound is found in the blank at the minimum level for each level of chlorination given in Table 2 (assuming a response factor of 1 relative to the internal standard at that level of chlorination for compounds not listed in Table 1), analysis of samples is halted until the blank associated with the sample batch shows no evidence of contamination at this level. All samples must be associated with an uncontaminated method blank before the results for those samples may be reported for regulatory compliance purposes.
- 9.6** QC Check Sample—Analyze the QC Check Sample (Section 7.16) periodically to assure the accuracy of calibration standards and the overall reliability of the analytical process. It is suggested that the QC Check Sample be analyzed at least quarterly.
- 9.7** The specifications contained in this method can be met if the apparatus used is calibrated properly and then maintained in a calibrated state. The standards used for calibration (Section 10), calibration verification (Section 15.3), and for initial (Section 9.2) and ongoing (Section 15.5) precision and recovery should be identical, so that the most precise results will be obtained. A GC/MS instrument will provide the most reproducible results if dedicated to the settings and conditions required for the analyses of PCBs by this method.
- 9.8** Depending on specific program requirements, field replicates may be collected to determine the precision of the sampling technique, and spiked samples may be required to determine the accuracy of the analysis when the internal standard method is used.

10.0 Calibration

10.1 Establish the operating conditions necessary to meet the minimum retention times for the internal standards in Section 10.2.4 and the relative retention times for the PCBs in Table 2.

10.1.1 Suggested GC operating conditions:

Injector temperature:	290°C
Interface temperature:	290°C
Initial temperature:	150°C
Initial time:	2 minutes
Temperature program:	150 to 200°C at 10°C/minute 200 to 280°C at 2.0°C/minute

Note: *All portions of the column that connect the GC to the ion source shall remain at or above the interface temperature specified above during analysis to preclude condensation of less volatile compounds.*

The GC conditions may be optimized for compound separation and sensitivity. Once optimized, the same GC conditions must be used for the analysis of all standards, blanks, IPR and OPR aliquots, and samples.

10.1.2 Mass spectrometer (MS) resolution—Obtain a selected ion current profile (SICP) of each analyte in Table 3 at the two exact m/z 's specified in Table 8 and at $\geq 10,000$ resolving power by injecting an authentic standard of the PCBs either singly or as part of a mixture in which there is no interference between closely eluted components.

10.1.2.1 The analysis time for PCBs may exceed the long-term mass stability of the mass spectrometer. Because the instrument is operated in the high-resolution mode, mass drifts of a few ppm (e.g., 5 ppm in mass) can have serious adverse effects on instrument performance. Therefore, a mass-drift correction is mandatory and a lock-mass m/z from PFK is used for drift correction. The lock-mass m/z is dependent on the exact m/z 's monitored within each descriptor, as shown in Table 8. The level of PFK metered into the HRMS during analyses should be adjusted so that the amplitude of the most intense selected lock-mass m/z signal (regardless of the descriptor number) does not exceed 10% of the full-scale deflection for a given set of detector parameters. Under those conditions, sensitivity changes that might occur during the analysis can be more effectively monitored.

Note: *Excessive PFK (or any other reference substance) may cause noise problems and contamination of the ion source necessitating increased frequency of source cleaning.*

10.1.2.2 If the HRMS has the capability to monitor resolution during the analysis, it is acceptable to terminate the analysis when the resolution falls below 10,000 to save reanalysis time.

10.1.2.3 Using a PFK molecular leak, tune the instrument to meet the minimum required resolving power of 10,000 (10% valley) at m/z 304.9824 or any other reference signal

close to m/z 305 (from PeCB). For each descriptor (Table 8), monitor and record the resolution and exact m/z 's of three to five reference peaks covering the mass range of the descriptor. The resolution must be greater than or equal to 10,000, and the deviation between the exact m/z and the theoretical m/z (Table 8) for each exact m/z monitored must be less than 5 ppm.

- 10.2** Ion abundance ratios, minimum levels, signal-to-noise ratios, and absolute retention times—Choose an injection volume of either 1- or 2- μ L, consistent with the capability of the HRGC/HRMS instrument. Inject a 1 or 2 μ L aliquot of the CS1 calibration solution (Table 4) using the GC conditions from Section 10.1.1. If PCBs 77, 126, and 169 only are to be determined, the operating conditions and specifications below apply to analysis of those compounds only.
- 10.2.1** Measure the SICP areas for each analyte, and compute the ion abundance ratios at the exact m/z 's specified in Table 8. Compare the computed ratio to the theoretical ratio given in Table 9.
- 10.2.1.1** The exact m/z 's to be monitored in each descriptor are shown in Table 8. Each group or descriptor shall be monitored in succession as a function of GC retention time to ensure that all of the toxic PCBs are detected. Additional m/z 's may be monitored in each descriptor, and the m/z 's may be divided among more than the descriptors listed in Table 8, provided that the laboratory is able to monitor the m/z 's of all the PCBs that may elute from the GC in a given retention-time window. If PCBs 77, 126, and 169 only are to be determined, the descriptors may be modified to include only the exact m/z 's for the tetra-, penta-, and hexa-, congeners, and the lock m/z 's.
- 10.2.1.2** The mass spectrometer shall be operated in a mass-drift correction mode, using PFK to provide lock m/z 's. The lock mass for each group of m/z 's is shown in Table 8. Each lock mass shall be monitored and shall not vary by more than $\pm 20\%$ throughout its respective retention time window. Variations of the lock mass by more than 20% indicate the presence of coeluting interferences that may significantly reduce the sensitivity of the mass spectrometer. Reinjection of another aliquot of the sample extract will not resolve the problem. Additional cleanup of the extract may be required to remove the interferences.
- 10.2.2** All PCBs and labeled compounds in the CS1 standard shall be within the QC limits in Table 9 for their respective ion abundance ratios; otherwise, the mass spectrometer shall be adjusted and this test repeated until the m/z ratios fall within the limits specified. If the adjustment alters the resolution of the mass spectrometer, resolution shall be verified (Section 10.1.2) prior to repeat of the test.
- 10.2.3** Verify that the HRGC/HRMS instrument meets the minimum levels in Table 2. The peaks representing the PCBs and labeled compounds in the CS1 calibration standard must have signal-to-noise ratios (S/N) greater than or equal to 10.0. Otherwise, the mass spectrometer shall be adjusted and this test repeated until the minimum levels in Table 2 are met.
- 10.2.4** The absolute retention time of PCB 169 (Section 7.12) shall exceed 20 minutes on the SPB-Octyl column, and the retention time of PCB 157 shall exceed 25 minutes on the DB-1 column; otherwise, the GC temperature program shall be adjusted and this test repeated until the above-stated minimum retention time criteria are met.

- 10.3** Retention-time windows—Analyze the window defining mixtures (Section 7.15) using the optimized temperature program in Section 10.1. Table 5 gives the elution order (first/last) of the window-defining compounds. If PCBs 77, 126, and 169 only are to be determined, the window-defining tetra-, penta-, and hepta-PCBs are the only compounds that need to be tested.
- 10.4** Isomer specificity.
- 10.4.1** Analyze the isomer specificity test standards (Section 7.15) using the procedure in Section 14 and the optimized conditions for sample analysis (Section 10.1.1).
- 10.4.2** Compute the percent valley between the GC peaks that elute most closely to PCB 126 and 169 on the SPB-Octyl column and to PCB 156/157 on the DB-1 column, per Figures 6 and 7.
- 10.4.3** Verify that the height of the valley between the most closely eluted isomers and the PCBs given in Section 10.4.2 is less than 25% (computed as $100 \times y$ in Figures 6 and 7). If the valley exceeds 25%, adjust the analytical conditions and repeat the test or replace the GC column and recalibrate (Sections 10.1.2 through 10.7).
- 10.5** Calibration by isotope dilution—Isotope dilution calibration is used for the native PCBs for which labeled compounds are added to samples prior to extraction. The reference compound for each native compound is shown in Table 2.
- 10.5.1** A calibration curve encompassing the concentration range is prepared for each compound to be determined. The relative response (RR) (labeled to native) vs. concentration in standard solutions is plotted or computed using a linear regression. Relative response is determined according to the procedures described below. Five calibration points are employed.
- 10.5.2** The response of each native PCB relative to its labeled analog is determined using the area responses of both the primary and secondary exact m/z 's specified in Table 8, for each calibration standard as follows:

$$RR = \frac{(AI_n + A2_n) C_l}{(AI_l + A2_l) C_n}$$

Where:

AI_n and $A2_n$ = The areas of the primary and secondary m/z 's for the PCB.

AI_l and $A2_l$ = The areas of the primary and secondary m/z 's for the labeled compound.

C_l = The concentration of the labeled compound in the calibration standard (Table 4).

C_n = The concentration of the native compound in the calibration standard (Table 4).

- 10.5.3** To calibrate the analytical system by isotope dilution, inject a volume of calibration standards CS1 through CS5 (Section 7.13 and Table 4) identical to the volume chosen in Section 10.2, using the procedure in Section 14 and the conditions in Section 10.1.1 and Table 2. Compute the relative response (RR) at each concentration.
- 10.5.4** Linearity—If the relative response for any compound is constant (less than 20% coefficient of variation) over the five-point calibration range, an averaged relative response may be used for that compound; otherwise, the complete calibration curve for that compound shall be used over the five-point calibration range.

10.6 Calibration by internal standard—The internal standard method is applied to determination of the native PCBs for which a labeled compound is not available and to the determination of labeled compounds for intralaboratory statistics (Sections 9.4 and 15.5.4).

10.6.1 Response factors—Calibration requires the determination of response factors (RF) defined by the following equation:

$$RF = \frac{(A1_s + A2_s) C_{is}}{(A1_{is} + A2_{is}) C_s}$$

Where:

$A1_s$ and $A2_s$ = The areas of the primary and secondary m/z's for the PCB.

$A1_{is}$ and $A2_{is}$ = The areas of the primary and secondary m/z's for the internal standard.

C_{is} = The concentration of the internal standard (Table 4).

C_s = The concentration of the compound in the calibration standard (Table 4).

Note: There is only one m/z for PCBs 81 and 111 (see Table 8).

10.6.2 To calibrate the analytical system by internal standard, inject 1.0 or 2.0 μ L of calibration standards CS1 through CS5 (Section 7.13 and Table 4) using the procedure in Section 14 and the conditions in Section 10.1.1 and Table 2. Compute the response factor (RF) at each concentration.

10.6.3 Linearity—If the response factor (RF) for any compound is constant (less than 35% coefficient of variation) over the five-point calibration range, an averaged response factor may be used for that compound; otherwise, the complete calibration curve for that compound shall be used over the five-point range.

10.7 Combined calibration—By using calibration solutions (Section 7.13 and Table 4) containing the native PCBs, labeled compounds, and the internal standards, a single set of analyses can be used to produce calibration curves for the isotope dilution and internal standard methods. These curves are verified (Section 15.3) each shift by analyzing the calibration verification standard (VER, Table 4). Recalibration is required if any of the calibration verification criteria (Section 15.3) cannot be met.

10.8 Data storage—MS data shall be collected, recorded, and stored.

10.8.1 Data acquisition—The signal at each exact m/z shall be collected repetitively throughout the monitoring period and stored on a mass storage device.

10.8.2 Response factors and multipoint calibrations—The data system shall be used to record and maintain lists of response factors (response ratios for isotope dilution) and multipoint calibration curves. Computations of relative standard deviation (coefficient of variation) shall be used to test calibration linearity. Statistics on initial performance (Section 9.2) and ongoing

performance (Section 15.5) should be computed and maintained, either on the instrument data system or on a separate computer system.

11.0 Sample Preparation

- 11.1** Sample preparation involves modifying the physical form of the sample so that the PCBs can be extracted efficiently. In general, the samples must be in a liquid form or in the form of finely divided solids in order for efficient extraction to take place. Table 10 lists the phases and suggested quantities for extraction of various sample matrices.

For samples known or expected to contain high levels of the PCBs, the smallest sample size representative of the entire sample should be used (see Section 17.5).

For all samples, the blank and IPR/OPR aliquots must be processed through the same steps as the sample to check for contamination and losses in the preparation processes.

- 11.1.1** For samples that contain particles, percent solids and particle size are determined using the procedures in Sections 11.2 and 11.3, respectively.
- 11.1.2** Aqueous samples—Because PCBs may be bound to suspended particles, the preparation of aqueous samples is dependent on the solids content of the sample.
- 11.1.2.1** Aqueous samples containing 1% solids or less are prepared per Section 11.4 and extracted directly using the SPE technique in 12.2.
- 11.1.2.2** For aqueous samples containing greater than 1% solids, a sample aliquot sufficient to provide 10 g of dry solids is used as described in Section 11.5.
- 11.1.3** Solid samples are prepared using the procedure described in Section 11.5 followed by extraction via the SDS procedure in Section 12.3.
- 11.1.4** Multiphase samples—The phase(s) containing the PCBs is separated from the non-PCB phase using pressure filtration and centrifugation as described in Section 11.6. The PCBs will be in the organic phase in a multiphase sample in which an organic phase exists.
- 11.1.5** Procedures for grinding, homogenization, and blending of various sample phases are given in Section 11.7.
- 11.1.6** Tissue samples—Preparation procedures for fish and other tissues are given in Section 11.8.
- 11.2** Determination of percent suspended solids.

Note: *This aliquot is used for determining the solids content of the sample, not for determination of PCBs.*

- 11.2.1** Aqueous liquids and multi-phase samples consisting of mainly an aqueous phase.
- 11.2.1.1** Desiccate and weigh a GF/D filter (Section 6.5.3) to three significant figures.
- 11.2.1.2** Filter 10.0 ± 0.02 mL of well-mixed sample through the filter.
- 11.2.1.3** Dry the filter a minimum of 12 hours at $110 \pm 5^\circ\text{C}$ and cool in a desiccator.

11.2.1.4 Calculate percent solids as follows:

$$\% \text{ solids} = \frac{\text{weight of sample aliquot plus filter after drying (g)} - \text{weight of filter (g)}}{10 \text{ g}} \times 100$$

11.2.2 Non-aqueous liquids, solids, semi-solid samples, and multi-phase samples in which the main phase is not aqueous, but not tissues.

11.2.2.1 Weigh 5 to 10 g of sample to three significant figures in a tared beaker.

11.2.2.2 Dry a minimum of 12 hours at $110 \pm 5^\circ\text{C}$, and cool in a desiccator.

11.2.2.3 Calculate percent solids as follows:

$$\% \text{ solids} = \frac{\text{weight of sample aliquot after drying}}{\text{weight of sample aliquot before drying}} \times 100$$

11.3 Determination of particle size.

11.3.1 Spread the dried sample from Section 11.2.2.2 on a piece of filter paper or aluminum foil in a fume hood or glove box.

11.3.2 Estimate the size of the particles in the sample. If the size of the largest particles is greater than 1 mm, the particle size must be reduced to 1 mm or less prior to extraction using the procedures in Section 11.7.

11.4 Preparation of aqueous samples containing 1% suspended solids or less.

11.4.1 Aqueous samples containing 1% suspended solids or less are prepared using the procedure below and extracted using the SPE technique in Section 12.2.

11.4.2 Preparation of sample and QC aliquots.

11.4.2.1 Mark the original level of the sample on the sample bottle for reference. Weigh the sample plus bottle to ± 1 g.

11.4.2.2 Spike 1.0 mL of the diluted labeled-compound spiking solution (Section 7.10.3) into the sample bottle. Cap the bottle and mix the sample by careful shaking. Allow the sample to equilibrate for 1 to 2 hours, with occasional shaking.

11.4.2.3 For each sample or sample batch (to a maximum of 20 samples) to be extracted during the same 12-hour shift, place two 1.0-L aliquots of reagent water in clean sample bottles or flasks.

11.4.2.4 Spike 1.0 mL of the diluted labeled-compound spiking solution (Section 7.10.3) into both reagent water aliquots. One of these aliquots will serve as the method blank.

11.4.2.5 Spike 1.0 mL of the PAR standard (Section 7.14) into the remaining reagent water aliquot. This aliquot will serve as the OPR (Section 15.5).

11.4.2.6 Add 5 mL of methanol to the sample and QC aliquots. Cap and shake the sample and QC aliquots to mix thoroughly and proceed to Section 12.2 for extraction.

- 11.5** Preparation of samples containing greater than 1% solids.
- 11.5.1** Weigh a well-mixed aliquot of each sample (of the same matrix type) sufficient to provide 10 g of dry solids (based on the solids determination in Section 11.2) into a clean beaker or glass jar.
 - 11.5.2** Spike 1.0 mL of the diluted labeled compound spiking solution (Section 7.10.3) into the sample.
 - 11.5.3** For each sample or sample batch (to a maximum of 20 samples) to be extracted during the same 12 hour shift, weigh two 10-g aliquots of the appropriate reference matrix (Section 7.6) into clean beakers or glass jars.
 - 11.5.4** Spike 1.0 mL of the diluted labeled compound spiking solution (Section 7.10.3) into each reference matrix aliquot. One aliquot will serve as the method blank. Spike 1.0 mL of the PAR standard (Section 7.14) into the other reference matrix aliquot. This aliquot will serve as the OPR (Section 15.5).
 - 11.5.5** Stir or tumble and equilibrate the aliquots for 1 to 2 hours.
 - 11.5.6** Decant excess water. If necessary to remove water, filter the sample through a glass-fiber filter (Section 6.5.6) and discard the aqueous liquid.
 - 11.5.7** If particles >1 mm are present in the sample (as determined in Section 11.3.2), spread the sample on clean aluminum foil in a hood. After the sample is dry, grind to reduce the particle size (Section 11.7).
 - 11.5.8** Extract the sample and QC aliquots using the SDS procedure in Section 12.3.
- 11.6** Multiphase samples.
- 11.6.1** Using the percent solids determined in Section 11.2.1 or 11.2.2, determine the volume of sample that will provide 10 g of solids, up to 1 L of sample.
 - 11.6.2** Pressure filter the amount of sample determined in Section 11.6.1 through Whatman GF/D glass-fiber filter paper (Section 6.5.3). Pressure filter the blank and OPR aliquots through GF/D papers also. If necessary to separate the phases and/or settle the solids, centrifuge these aliquots prior to filtration.
 - 11.6.3** Discard any aqueous phase (if present). Remove any non-aqueous liquid present and reserve the maximum amount filtered from the sample (Section 11.6.1) or 10 g, whichever is less, for combination with the solid phase (Section 12.3.5).
 - 11.6.4** If particles >1 mm are present in the sample (as determined in Section 11.3.2) and the sample is capable of being dried, spread the sample and QC aliquots on clean aluminum foil in a hood. After the aliquots are dry, or if the sample cannot be dried, reduce the particle size using the procedures in Section 11.7 and extract the reduced particles using the SDS procedure in Section 12.3. If particles >1 mm are not present, extract the particles and filter in the sample and QC aliquots directly using the SDS procedure in Section 12.3.
- 11.7** Sample grinding, homogenization, or blending—Samples with particle sizes greater than 1 mm (as determined in Section 11.3.2) are subjected to grinding, homogenization, or blending. The method of reducing particle size to less than 1 mm is matrix-dependent. In general, hard particles can be reduced by grinding with a mortar and pestle. Softer particles can be reduced by grinding in a Wiley mill or meat grinder, by homogenization, or in a blender.

- 11.7.1** Each size-reducing preparation procedure on each matrix shall be verified by running the tests in Section 9.2 before the procedure is employed routinely.
- 11.7.2** The grinding, homogenization, or blending procedures shall be carried out in a glove box or fume hood to prevent particles from contaminating the work environment.
- 11.7.3** Grinding—Certain papers and pulps, slurries, and amorphous solids can be ground in a Wiley mill or heavy duty meat grinder. In some cases, reducing the temperature of the sample to freezing or to dry ice or liquid nitrogen temperatures can aid in the grinding process. Grind the sample aliquots from Sections 11.5.7 or 11.6.4 in a clean grinder. Do not allow the sample temperature to exceed 50°C. Grind the blank and reference matrix aliquots using a clean grinder.
- 11.7.4** Homogenization or blending—Particles that are not ground effectively, or particles greater than 1 mm in size after grinding, can often be reduced in size by high speed homogenization or blending. Homogenize and/or blend the particles or filter from Sections 11.5.7 or 11.6.4 for the sample, blank, and OPR aliquots.
- 11.7.5** Extract the aliquots using the SDS procedure in Section 12.3.
- 11.8** Fish and other tissues—Prior to processing tissue samples, the laboratory must determine the exact tissue to be analyzed. Common requests for analysis of fish tissue include whole fish–skin on, whole fish–skin removed, edible fish fillets (filleted in the field or by the laboratory), specific organs, and other portions. Once the appropriate tissue has been determined, the sample must be homogenized.
 - 11.8.1** Homogenization.
 - 11.8.1.1** Samples are homogenized while still frozen, where practical. If the laboratory must dissect the whole fish to obtain the appropriate tissue for analysis, the unused tissues may be rapidly refrozen and stored in a clean glass jar for subsequent use.
 - 11.8.1.2** Each analysis requires 10 g of tissue (wet weight). Therefore, the laboratory should homogenize at least 20 g of tissue to allow for re-extraction of a second aliquot of the same homogenized sample, if re-analysis is required. When whole fish analysis is necessary, the entire fish is homogenized.
 - 11.8.1.3** Homogenize the sample in a tissue homogenizer (Section 6.3.3) or grind in a meat grinder (Section 6.3.4). Cut tissue too large to feed into the grinder into smaller pieces. To assure homogeneity, grind three times.
 - 11.8.1.4** Transfer approximately 10 g (wet weight) of homogenized tissue to a clean, tared, 400- to 500-mL beaker.
 - 11.8.1.5** Transfer the remaining homogenized tissue to a clean jar with a fluoropolymer-lined lid. Seal the jar and store the tissue at <-10°C. Return any tissue that was not homogenized to its original container and store at <-10°C.
 - 11.8.2** QC aliquots.
 - 11.8.2.1** Prepare a method blank by adding approximately 10 g of the oily liquid reference matrix (Section 7.6.4) to a 400- to 500-mL beaker.

- 11.8.2.2** Prepare a precision and recovery aliquot by adding approximately 10 g of the oily liquid reference matrix (Section 7.6.4) to a separate 400- to 500-mL beaker. Record the weight to the nearest 10 mg. If the initial precision and recovery test is to be performed, use four aliquots; if the ongoing precision and recovery test is to be performed, use a single aliquot.
- 11.8.3** Spiking.
- 11.8.3.1** Spike 1.0 mL of the labeled compound spiking solution (Section 7.10.3) into the sample, blank, and OPR aliquot.
- 11.8.3.2** Spike 1.0 mL of the PAR standard (Section 7.14) into the OPR aliquot.
- 11.8.4** Extract the aliquots using the procedures in Section 12.4.

12.0 Extraction and Concentration

- 12.1** Extraction procedures include solid phase (Section 12.2) for aqueous liquids; Soxhlet/Dean-Stark (Section 12.3) for solids and filters; and Soxhlet extraction (Section 12.4) for tissues. Acid/base back-extraction (Section 12.5) is used for initial cleanup of extracts.
- Macro-concentration procedures include rotary evaporation (Section 12.6.1), heating mantle (Section 12.6.2), and Kuderna-Danish (K-D) evaporation (Section 12.6.3). Micro-concentration uses nitrogen blowdown (Section 12.7).
- 12.2** SPE of samples containing less than 1% solids.
- 12.2.1** Disk preparation.
- 12.2.1.1** Remove the test tube from the suction flask (Figure 4). Place an SPE disk on the base of the filter holder and wet with methylene chloride. While holding a GMF 150 filter above the SPE disk with tweezers, wet the filter with methylene chloride and lay the filter on the SPE disk, making sure that air is not trapped between the filter and disk. Clamp the filter and SPE disk between the 1-L glass reservoir and the vacuum filtration flask.
- 12.2.1.2** Rinse the sides of the reservoir with approximately 15 mL of methylene chloride using a squeeze bottle or pipet. Apply vacuum momentarily until a few drops appear at the drip tip. Release the vacuum and allow the filter/disk to soak for approximately one minute. Apply vacuum and draw all of the methylene chloride through the filter/disk. Repeat the wash step with approximately 15 mL of acetone and allow the filter/disk to air dry.
- 12.2.2** Sample extraction.
- 12.2.2.1** Pre-wet the disk by adding approximately 20 mL of methanol to the reservoir. Pull most of the methanol through the filter/disk, retaining a layer of methanol approximately 2 mm thick on the filter. Do not allow the filter/disk to go dry from this point until the extraction is completed.
- 12.2.2.2** Add approximately 20 mL of reagent water to the reservoir and pull most through, leaving a layer approximately 2 mm thick on the filter/disk.
- 12.2.2.3** Allow the sample (Section 11.4.2.2) to stand for 1-2 hours, if necessary, to settle the suspended particles. Decant the clear layer of the sample, the blank (Section 11.4.2.4), or IPR/OPR aliquot (Section 11.4.2.5) into the reservoir and turn on the vacuum to begin the extraction. Adjust the vacuum to complete the extraction in no less than 10 minutes.

For samples containing a high concentration of particles (suspended solids), the extraction time may be one hour or longer.

12.2.2.4 Before all of the sample has been pulled through the filter/disk, add approximately 50 mL of reagent water to the sample bottle, swirl to suspend the solids (if present), and pour into the reservoir. Pull through the filter/disk. Use additional reagent water rinses until all solids are removed.

12.2.2.5 Before all of the sample and rinses have been pulled through the filter/disk, rinse the sides of the reservoir with small portions of reagent water.

12.2.2.6 Partially dry the filter/disk under vacuum for approximately 3 minutes.

12.2.3 Elution of the filter/disk.

12.2.3.1 Release the vacuum, remove the entire filter/disk/reservoir assembly from the vacuum flask, and empty the flask. Insert a test tube for eluant collection into the flask. The test tube should have sufficient capacity to contain the total volume of the elution solvent (approximately 50 mL) and should fit around the drip tip. The drip tip should protrude into the test tube to preclude loss of sample from spattering when vacuum is applied. Reassemble the filter/disk/reservoir assembly on the vacuum flask.

12.2.3.2 Wet the filter/disk with 4-5 mL of acetone. Allow the acetone to spread evenly across the disk and soak for 15-20 seconds. Pull the acetone through the disk, releasing the vacuum when approximately 1 mm thickness remains on the filter.

12.2.3.3 Rinse the sample bottle with approximately 20 mL of methylene chloride and transfer to the reservoir. Pull approximately half of the solvent through the filter/disk and release the vacuum. Allow the filter/disk to soak for approximately 1 minute. Pull all of the solvent through the disk. Repeat the bottle rinsing and elution step with another 20 mL of methylene chloride. Pull all of the solvent through the disk.

12.2.3.4 Release the vacuum, remove the filter/disk/reservoir assembly, and remove the test tube containing the sample solution. Quantitatively transfer the solution to a 250-mL separatory funnel and proceed to Section 12.5 for back-extraction.

12.3 SDS extraction of samples containing particles.

12.3.1 Charge a clean extraction thimble (Section 6.4.2.2) with 5.0 g of 100/200 mesh silica (Section 7.5.1.1) topped with 100 g of quartz sand (Section 7.3.2).

Note: *Do not disturb the silica layer throughout the extraction process.*

12.3.2 Place the thimble in a clean extractor. Place 30 to 40 mL of toluene in the receiver and 200 to 250 mL of toluene in the flask.

12.3.3 Pre-extract the glassware by heating the flask until the toluene is boiling. When properly adjusted, 1 to 2 drops of toluene will fall per second from the condenser tip into the receiver. Extract the apparatus for a minimum of 3 hours.

12.3.4 After pre-extraction, cool and disassemble the apparatus. Rinse the thimble with toluene and allow to air dry.

-
- 12.3.5** Load the wet sample and/or filter from Sections 11.5.8, 11.6.4, 11.7.3, or 11.7.4 and any non-aqueous liquid from Section 11.6.3 into the thimble and manually mix into the sand layer with a clean metal spatula, carefully breaking up any large lumps of sample.
- 12.3.6** Reassemble the pre-extracted SDS apparatus, and add a fresh charge of toluene to the receiver and reflux flask. Apply power to the heating mantle to begin refluxing. Adjust the reflux rate to match the rate of percolation through the sand and silica beds until water removal lessens the restriction to toluene flow. Frequently check the apparatus for foaming during the first 2 hours of extraction. If foaming occurs, reduce the reflux rate until foaming subsides.
- 12.3.7** Drain the water from the receiver at 1 to 2 hours and 8 to 9 hours, or sooner if the receiver fills with water. Reflux the sample for a total of 16 to 24 hours. Cool and disassemble the apparatus. Record the total volume of water collected.
- 12.3.8** Remove the distilling flask. Drain the water from the Dean-Stark receiver and add any toluene in the receiver to the extract in the flask.
- 12.3.9** Concentrate the extracts from particles (Sections 11.5-11.7) to approximately 10 mL using the rotary evaporator or heating mantle (Section 12.6.1 or 12.6.2), transfer to a 250-mL separatory funnel, and proceed with back-extraction (Section 12.5).
- 12.4** Extraction of tissue.
- 12.4.1** Add 30 to 40 g of powdered anhydrous sodium sulfate to each of the beakers (Section 11.8.1.4, 11.8.2.1, and 11.8.2.2) and mix thoroughly. Cover the beakers with aluminum foil and allow to equilibrate for 12-24 hours. Remix prior to extraction to prevent clumping.
- 12.4.2** Assemble and pre-extract the Soxhlet apparatus per Sections 12.3.1-12.3.4, except use the methylene chloride:n-hexane (1:1) mixture for the pre-extraction and rinsing and omit the quartz sand. The Dean-Stark moisture trap may also be omitted, if desired.
- 12.4.3** Reassemble the pre-extracted Soxhlet apparatus and add a fresh charge of methylene chloride:n-hexane to the reflux flask.
- 12.4.4** Transfer the sample/sodium sulfate mixture (Section 12.4.1) to the Soxhlet thimble, and install the thimble in the Soxhlet apparatus.
- 12.4.5** Rinse the beaker with several portions of solvent mixture and add to the thimble. Fill the thimble/receiver with solvent. Extract for 18 to 24 hours.
- 12.4.6** After extraction, cool and disassemble the apparatus.
- 12.4.7** Quantitatively transfer the extract to a macro-concentration device (Section 12.6), and concentrate to near dryness. Set aside the concentration apparatus for re-use.
- 12.4.8** Complete the removal of the solvent using the nitrogen blowdown procedure (Section 12.7) and a water bath temperature of 60°C. Weigh the receiver, record the weight, and return the receiver to the blowdown apparatus, concentrating the residue until a constant weight is obtained.
- 12.4.9** Percent lipid determination—The lipid content is determined by extraction of tissue with the same solvent system (methylene chloride:n-hexane) that was used in EPA's National Dioxin Study (Reference 15) so that lipid contents are consistent with that study.

- 12.4.9.1** Redissolve the residue in the receiver in n-hexane and spike 1.0 mL of the cleanup standard (Section 7.11) into the solution.
- 12.4.9.2** Transfer the residue/n-hexane to the anthropogenic isolation column (Section 13.6.1), retaining the boiling chips in the concentration apparatus. Use several rinses to assure that all material is transferred. If necessary, sonicate or heat the receiver slightly to assure that all material is re-dissolved. Allow the receiver to dry. Weigh the receiver and boiling chips.
- 12.4.9.3** Calculate the lipid content to the nearest three significant figures as follows:

$$\text{Percent lipid content} = \frac{\text{Weight of residue (g)}}{\text{Weight of tissue (g)}} \times 100$$

- 12.4.9.4** It is not necessary to determine the lipid content of the blank, IPR, or OPR aliquots.

12.5 Back-extraction with base and acid.

- 12.5.1** Spike 1.0 mL of the cleanup standard (Section 7.11) into the separatory funnels containing the sample and QC extracts from Section 12.2.3.4 or 12.3.9.
- 12.5.2** Partition the extract against 50 mL of potassium hydroxide solution (Section 7.1.1). Shake for 2 minutes with periodic venting into a hood. Remove and discard the aqueous layer. Repeat the base washing until no color is visible in the aqueous layer to a maximum of four washings. Minimize contact time between the extract and the base to prevent degradation of the PCBs. Stronger potassium hydroxide solutions may be employed for back-extraction, provided that the laboratory meets the specifications for labeled compound recovery and demonstrates acceptable performance using the procedure in Section 9.2.
- 12.5.3** Partition the extract against 50 mL of sodium chloride solution (Section 7.1.4) in the same way as with base. Discard the aqueous layer.
- 12.5.4** Partition the extract against 50 mL of sulfuric acid (Section 7.1.2) in the same way as with base. Repeat the acid washing until no color is visible in the aqueous layer to a maximum of four washings.
- 12.5.5** Repeat the partitioning against sodium chloride solution and discard the aqueous layer.
- 12.5.6** Pour each extract through a drying column containing 7 to 10 cm of granular anhydrous sodium sulfate (Section 7.2.1). Rinse the separatory funnel with 30 to 50 mL of solvent, and pour through the drying column. Collect each extract in a round-bottom flask. Re-concentrate the sample and QC aliquots per Sections 12.6-12.7, and clean up the samples and QC aliquots per Section 13.
- 12.6** Macro-concentration—Extracts in toluene are concentrated using a rotary evaporator or a heating mantle; extracts in methylene chloride or n-hexane are concentrated using a rotary evaporator, heating mantle, or Kuderna-Danish apparatus.
- 12.6.1** Rotary evaporation—Concentrate the extracts in separate round-bottom flasks.
- 12.6.1.1** Assemble the rotary evaporator according to manufacturer's instructions, and warm the water bath to 45°C. On a daily basis, preclean the rotary evaporator by concentrating

100 mL of clean extraction solvent through the system. Archive both the concentrated solvent and the solvent in the catch flask for a contamination check if necessary. Between samples, three 2- to 3-mL aliquots of solvent should be rinsed down the feed tube into a waste beaker.

- 12.6.1.2** Attach the round-bottom flask containing the sample extract to the rotary evaporator. Slowly apply vacuum to the system, and begin rotating the sample flask.
- 12.6.1.3** Lower the flask into the water bath, and adjust the speed of rotation and the temperature as required to complete concentration in 15 to 20 minutes. At the proper rate of concentration, the flow of solvent into the receiving flask will be steady, but no bumping or visible boiling of the extract will occur.

Note: *If the rate of concentration is too fast, analyte loss may occur.*

- 12.6.1.4** When the liquid in the concentration flask has reached an apparent volume of approximately 2 mL, remove the flask from the water bath and stop the rotation. Slowly and carefully admit air into the system. Be sure not to open the valve so quickly that the sample is blown out of the flask. Rinse the feed tube with approximately 2 mL of solvent.
 - 12.6.1.5** Proceed to Section 12.6.4 for preparation for back-extraction or micro-concentration and solvent exchange.
- 12.6.2** Heating mantle—Concentrate the extracts in separate round-bottom flasks.
- 12.6.2.1** Add one or two clean boiling chips to the round-bottom flask, and attach a three-ball macro-Snyder column. Pre-wet the column by adding approximately 1 mL of solvent through the top. Place the round-bottom flask in a heating mantle, and apply heat as required to complete the concentration in 15 to 20 minutes. At the proper rate of distillation, the balls of the column will actively chatter, but the chambers will not flood.
 - 12.6.2.2** When the liquid has reached an apparent volume of approximately 10 mL, remove the round-bottom flask from the heating mantle and allow the solvent to drain and cool for at least 10 minutes. Remove the Snyder column and rinse the glass joint into the receiver with small portions of solvent.
 - 12.6.2.3** Proceed to Section 12.6.4 for preparation for back-extraction or micro-concentration and solvent exchange.
- 12.6.3** Kuderna-Danish (K-D)—Concentrate the extracts in separate 500-mL K-D flasks equipped with 10-mL concentrator tubes. The K-D technique is used for solvents such as methylene chloride and n-hexane. Toluene is difficult to concentrate using the K-D technique unless a water bath fed by a steam generator is used.
- 12.6.3.1** Add 1 to 2 clean boiling chips to the receiver. Attach a three-ball macro-Snyder column. Pre-wet the column by adding approximately 1 mL of solvent through the top. Place the K-D apparatus in a hot water bath so that the entire lower rounded surface of the flask is bathed with steam.

- 12.6.3.2** Adjust the vertical position of the apparatus and the water temperature as required to complete the concentration in 15 to 20 minutes. At the proper rate of distillation, the balls of the column will actively chatter but the chambers will not flood.
- 12.6.3.3** When the liquid has reached an apparent volume of 1 mL, remove the K-D apparatus from the bath and allow the solvent to drain and cool for at least 10 minutes. Remove the Snyder column and rinse the flask and its lower joint into the concentrator tube with 1 to 2 mL of solvent. A 5-mL syringe is recommended for this operation.
- 12.6.3.4** Remove the three-ball Snyder column, add a fresh boiling chip, and attach a two-ball micro-Snyder column to the concentrator tube. Pre-wet the column by adding approximately 0.5 mL of solvent through the top. Place the apparatus in the hot water bath.
- 12.6.3.5** Adjust the vertical position and the water temperature as required to complete the concentration in 5 to 10 minutes. At the proper rate of distillation, the balls of the column will actively chatter but the chambers will not flood.
- 12.6.3.6** When the liquid reaches an apparent volume of 0.5 mL, remove the apparatus from the water bath and allow to drain and cool for at least 10 minutes.
- 12.6.3.7** Proceed to 12.6.4 for preparation for back-extraction or micro-concentration and solvent exchange.

12.6.4 Preparation for back-extraction or micro-concentration and solvent exchange.

- 12.6.4.1** For back-extraction (Section 12.5), transfer the extract to a 250-mL separatory funnel. Rinse the concentration vessel with small portions of n-hexane, adjust the n-hexane volume in the separatory funnel to 10 to 20 mL, and proceed to back-extraction (Section 12.5).
- 12.6.4.2** For determination of the weight of residue in the extract or for clean-up procedures other than back-extraction, transfer the extract to a blowdown vial using 2-3 rinses of solvent. Proceed with micro-concentration and solvent exchange (Section 12.7).

12.7 Micro-concentration and solvent exchange.

- 12.7.1** Extracts to be subjected to GPC or HPLC cleanup are exchanged into methylene chloride. Extracts to be cleaned up using silica gel, carbon, and/or Florisil are exchanged into n-hexane.
- 12.7.2** Transfer the vial containing the sample extract to a nitrogen blowdown device. Adjust the flow of nitrogen so that the surface of the solvent is just visibly disturbed.

Note: *A large vortex in the solvent may cause analyte loss.*

- 12.7.3** Lower the vial into a 45°C water bath and continue concentrating.
 - 12.7.3.1** If the extract is to be concentrated to dryness for weight determination (Sections 12.4.8 and 13.6.4), blow dry until a constant weight is obtained.
 - 12.7.3.2** If the extract is to be concentrated for injection into the GC/MS or the solvent is to be exchanged for extract cleanup, proceed as follows:
- 12.7.4** When the volume of the liquid is approximately 100 µL, add 2 to 3 mL of the desired solvent (methylene chloride for GPC and HPLC, or n-hexane for the other cleanups) and continue

concentration to approximately 100 μL . Repeat the addition of solvent and concentrate once more.

- 12.7.5** If the extract is to be cleaned up by GPC, adjust the volume of the extract to 5.0 mL with methylene chloride. If the extract is to be cleaned up by HPLC, further concentrate the extract to 30 μL . Proceed with GPC or HPLC cleanup (Section 13.2 or 13.5, respectively).
- 12.7.6** If the extract is to be cleaned up by column chromatography (silica gel, Carbowpak/Celite, or Florisil), bring the final volume to 1.0 mL with n-hexane. Proceed with column cleanups (Sections 13.3 - 13.4 and 13.7).
- 12.7.7** If the extract is to be concentrated for injection into the GC/MS (Section 14), quantitatively transfer the extract to a 0.3-mL conical vial for final concentration, rinsing the larger vial with n-hexane and adding the rinse to the conical vial. Reduce the volume to approximately 100 μL . Add 10 μL of nonane to the vial, and evaporate the solvent to the level of the nonane. Seal the vial and label with the sample number. Store in the dark at room temperature until ready for GC/MS analysis. If GC/MS analysis will not be performed on the same day, store the vial at $<-10^{\circ}\text{C}$.

13.0 Extract Cleanup

- 13.1** Cleanup may not be necessary for relatively clean samples (e.g., treated effluents, groundwater, drinking water). If particular circumstances require the use of a cleanup procedure, the analyst may use any or all of the procedures below or any other appropriate procedure. Before using a cleanup procedure, the analyst must demonstrate that the requirements of Section 9.2 can be met using the cleanup procedure. If PCBs 77, 126, and 169 only are to be determined, the cleanup procedures may be optimized for isolation of these compounds.
 - 13.1.1** Gel permeation chromatography (Section 13.2) removes high molecular weight interferences that cause GC column performance to degrade. It should be used for all soil and sediment extracts. It may be used for water extracts that are expected to contain high molecular weight organic compounds (e.g., polymeric materials, humic acids). It may also be used for tissue extracts after initial cleanup on the anthropogenic isolation column (Section 13.6).
 - 13.1.2** Acid, neutral, and basic silica gel (Section 13.3) and Florisil (Section 13.7) are used to remove nonpolar and polar interferences.
 - 13.1.3** Carbowpak/Celite (Section 13.4) can be used to separate PCBs 77, 126, and 169 from the mono- and di- ortho-substituted PCBs, if desired.
 - 13.1.4** HPLC (Section 13.5) is used to provide specificity for certain congeners and congener groups.
 - 13.1.5** The anthropogenic isolation column (Section 13.6) is used for removal of lipids from tissue samples.
- 13.2** Gel permeation chromatography (GPC).
 - 13.2.1** Column packing.
 - 13.2.1.1** Place 70 to 75 g of SX-3 Bio-beads (Section 6.7.1.1) in a 400- to 500-mL beaker.
 - 13.2.1.2** Cover the beads with methylene chloride and allow to swell overnight (a minimum of 12 hours).

13.2.1.3 Transfer the swelled beads to the column (Section 6.7.1.1) and pump solvent through the column, from bottom to top, at 4.5 to 5.5 mL/minute prior to connecting the column to the detector.

13.2.1.4 After purging the column with solvent for 1 to 2 hours, adjust the column head pressure to 7 to 10 psig and purge for 4 to 5 hours to remove air. Maintain a head pressure of 7 to 10 psig. Connect the column to the detector (Section 6.7.1.4).

13.2.2 Column calibration.

13.2.2.1 Load 5 mL of the calibration solution (Section 7.4) into the sample loop.

13.2.2.2 Inject the calibration solution and record the signal from the detector. The elution pattern will be corn oil, PCB 209, pentachlorophenol, perylene, and sulfur.

13.2.2.3 Set the "dump time" to allow >85% removal of the corn oil and >85% collection of PCB 209.

13.2.2.4 Set the "collect time" to the peak minimum between perylene and sulfur.

13.2.2.5 Verify the calibration with the calibration solution after every 20 extracts. Calibration is verified if the recovery of the pentachlorophenol is greater than 85%. If calibration is not verified, the system shall be recalibrated using the calibration solution, and the previous 20 samples shall be re-extracted and cleaned up using the calibrated GPC system.

13.2.3 Extract cleanup—GPC requires that the column not be overloaded. The column specified in this method is designed to handle a maximum of 0.5 g of high molecular weight material in a 5-mL extract. If the extract is known or expected to contain more than 0.5 g, the extract is split into aliquots for GPC, and the aliquots are combined after elution from the column. The residue content of the extract may be obtained gravimetrically by evaporating the solvent from a 50- μ L aliquot.

13.2.3.1 Filter the extract or load through the filter holder (Section 6.7.1.3) to remove the particles. Load the 5.0-mL extract onto the column.

13.2.3.2 Elute the extract using the calibration data determined in Section 13.2.2. Collect the eluate in a clean 400- to 500-mL beaker.

13.2.3.3 Rinse the sample loading tube thoroughly with methylene chloride between extracts to prepare for the next sample.

13.2.3.4 If a particularly dirty extract is encountered, a 5.0-mL methylene chloride blank shall be run through the system to check for carry-over.

13.2.3.5 Concentrate the eluate per Section 12.6 and Section 12.7 for further cleanup or injection into the GC/MS.

13.3 Silica gel cleanup.

13.3.1 Place a glass-wool plug in a 15-mm ID chromatography column (Section 6.7.4.2). Pack the column bottom to top with 1 g silica gel (Section 7.5.1.1), 4 g basic silica gel (Section 7.5.1.3), 1 g silica gel, 8 g acid silica gel (Section 7.5.1.2), 2 g silica gel, and 4 g granular anhydrous sodium sulfate (Section 7.2.1). Tap the column to settle the adsorbents.

-
- 13.3.2** Pre-elute the column with 50 to 100 mL of n-hexane. Close the stopcock when the n-hexane is within 1 mm of the sodium sulfate. Discard the eluate. Check the column for channeling. If channeling is present, discard the column and prepare another.
- 13.3.3** Apply the concentrated extract to the column. Open the stopcock until the extract is within 1 mm of the sodium sulfate.
- 13.3.4** Rinse the receiver twice with 1-mL portions of n-hexane, and apply separately to the column. Elute the PCBs with 25 mL of n-hexane and collect the eluate.
- 13.3.5** Concentrate the eluate per Section 12.6 and 12.7 for further cleanup or injection into the HPLC or GC/MS.
- 13.3.6** For extracts of samples known to contain large quantities of other organic compounds (such as paper mill effluents), it may be advisable to increase the capacity of the silica gel column. This may be accomplished by increasing the strengths of the acid and basic silica gels. The acid silica gel (Section 7.5.1.2) may be increased in strength to as much as 44% w/w (7.9 g sulfuric acid added to 10 g silica gel). The basic silica gel (Section 7.5.1.3) may be increased in strength to as much as 33% w/w (50 mL 1N NaOH added to 100 g silica gel), or the potassium silicate (Section 7.5.1.4) may be used.
-

Note: *The use of stronger acid silica gel (44% w/w) may lead to charring of organic compounds in some extracts. The charred material may retain some of the analytes and lead to lower recoveries of the PCBs. Increasing the strengths of the acid and basic silica gel may also require different volumes of n-hexane than those specified above to elute the analytes from the column. Therefore, the performance of the method after such modifications must be verified by the procedure in Section 9.2.*

13.4 Carbon column (Reference 16).

- 13.4.1** Cut both ends from a 50-mL disposable serological pipet (Section 6.7.3.2) to produce a 20-cm column. Fire-polish both ends and flare both ends if desired. Insert a glass-wool plug at one end, and pack the column with 3.6 g of Carbopak/Celite (Section 7.5.2.3) to form an adsorbent bed 20 cm long. Insert a glass-wool plug on top of the bed to hold the adsorbent in place.
- 13.4.2** Pre-elute the column with 20 mL each in succession of toluene, methylene chloride, and n-hexane.
- 13.4.3** When the solvent is within 1 mm of the column packing, apply the n-hexane sample extract to the column. Rinse the sample container twice with 1-mL portions of n-hexane and apply separately to the column. Apply 2 mL of n-hexane to complete the transfer.
- 13.4.4** Elute the column with 25 mL of n-hexane and collect the eluate. This fraction will contain the mono- and di-ortho PCBs. If carbon particles are present in the eluate, filter through glass-fiber filter paper.
- 13.4.5** Elute the column with 15 mL of methanol and discard the eluate. The fraction discarded will contain residual lipids and other potential interferents, if present.

- 13.4.6** Elute the column with 15 mL of toluene and collect the eluate. This fraction will contain PCBs 77, 126, and 169. If carbon particles are present in the eluate, filter through glass-fiber filter paper.
- 13.4.7** Concentrate the fractions per Section 12.6 and 12.7 for further cleanup or injection into the HPLC or GC/MS.
- 13.5** HPLC (Reference 17).
- 13.5.1** Column calibration.
- 13.5.1.1** Prepare a calibration standard containing the toxic congeners and other congeners of interest at a concentration of approximately TBD pg/ μ L in methylene chloride.
- 13.5.1.2** Inject 30 μ L of the calibration solution into the HPLC and record the signal from the detector. Collect the eluant for reuse. The elution order will be the mono- through deca-congeners.
- 13.5.1.3** Establish the collection time for the congeners of interest. Following calibration, flush the injection system with copious quantities of methylene chloride, including a minimum of five 50- μ L injections while the detector is monitored, to ensure that residual PCBs are removed from the system.
- 13.5.1.4** Verify the calibration with the calibration solution after every 20 extracts. Calibration is verified if the recovery of the PCBs from the calibration standard is 75 to 125% compared to the calibration (Section 13.5.1.1). If calibration is not verified, the system shall be recalibrated using the calibration solution, and the previous 20 samples shall be re-extracted and cleaned up using the calibrated system.
- 13.5.2** Extract cleanup—HPLC requires that the column not be overloaded. The column specified in this method is designed to handle a maximum of 30 μ L of extract. If the extract cannot be concentrated to less than 30 μ L, it is split into fractions and the fractions are combined after elution from the column.
- 13.5.2.1** Rinse the sides of the vial twice with 30 μ L of methylene chloride and reduce to 30 μ L with the evaporation apparatus (Section 6.8.3).
- 13.5.2.2** Inject the 30 μ L extract into the HPLC.
- 13.5.2.3** Elute the extract using the calibration data determined in Section 13.5.1. Collect the fraction(s) in a clean 20-mL concentrator tube containing 5 mL of n-hexane:acetone (1:1 v/v).
- 13.5.2.4** If an extract containing greater than TBD ng/mL of total PCBs is encountered, a 30- μ L methylene chloride blank shall be run through the system to check for carry-over.
- 13.5.2.5** Concentrate the eluate per Section 12.7 for injection into the GC/MS.
- 13.6** Anthropogenic isolation column (References 1-2)—Used for removal of lipids from tissue extracts.
- 13.6.1** Prepare the column as given in Section 7.5.3.
- 13.6.2** Pre-elute the column with 100 mL of n-hexane. Drain the n-hexane layer to the top of the column, but do not expose the sodium sulfate.

- 13.6.3** Load the sample and rinses (Section 12.4.9.2) onto the column by draining each portion to the top of the bed. Elute the PCBs from the column into the apparatus used for concentration (Section 12.4.7) using 200 mL of n-hexane.
- 13.6.4** Concentrate the cleaned up extract (Sections 12.6-12.7) to constant weight per Section 12.7.3.1. If more than 500 mg of material remains, repeat the cleanup using a fresh anthropogenic isolation column.
- 13.6.5** Redissolve the extract in a solvent suitable for the additional cleanups to be used (Section 13.2-13.5 and 13.7).
- 13.6.6** Spike 1.0 mL of the cleanup standard (Section 7.11) into the residue/solvent.
- 13.6.7** Clean up the extract using the procedures in Sections 13.2-13.5 and 13.7. Florisil (Section 13.7) and carbon (Section 13.4) are recommended as minimum additional cleanup steps.
- 13.6.8** Following cleanup, concentrate the extract to 10 μ L as described in Section 12.7 and proceed with the analysis in Section 14.
- 13.7** Florisil cleanup (Reference 18).
- 13.7.1** Begin to drain the n-hexane from the column (Section 7.5.4). Adjust the flow rate of eluant to 4.5-5.0 mL/min.
- 13.7.2** When the n-hexane is within 1 mm of the sodium sulfate, apply the sample extract (in n-hexane) to the column. Rinse the sample container twice with 1-mL portions of n-hexane and apply to the column.
- 13.7.3** Elute the mono-ortho and di-ortho PCBs with approximately 165 mL of n-hexane and collect the eluate. Elute the non-ortho co-planar PCBs with approximately 100 mL of 6% ether:n-hexane and collect the eluate. The exact volumes of solvents will need to be determined for each batch of Florisil. If the mono/di-ortho PCBs are not to be separated from the non-ortho co-planar PCBs, elute all PCBs with 6% ether:n-hexane.
- 13.7.4** Concentrate the eluate(s) per Sections 12.6-12.7 for further cleanup or for injection into the HPLC or GC/MS.

14.0 HRGC/HRMS Analysis

- 14.1** Establish the operating conditions given in Section 10.1.
- 14.2** Add 10 μ L of the appropriate internal standard solution (Section 7.12) to the sample extract immediately prior to injection to minimize the possibility of loss by evaporation, adsorption, or reaction. If an extract is to be reanalyzed and evaporation has occurred, do not add more instrument internal standard solution. Rather, bring the extract back to its previous volume (e.g., 19 μ L) with pure nonane only (18 μ L if 2 μ L injections are used).
- 14.3** Inject 1.0 or 2.0 μ L of the concentrated extract containing the internal standard solution, using on-column or splitless injection. The volume injected must be identical to the volume used for calibration (Section 10). Start the GC column initial isothermal hold upon injection. Start MS data collection after the solvent peak elutes. Stop data collection after the $^{13}\text{C}_{12}$ -PCB 209 has eluted. If PCBs 77, 126, and 169 only are to be determined, stop data collection after $^{13}\text{C}_{12}$ -PCB 169 has eluted. Return the column to the initial temperature for analysis of the next extract or standard.

15.0 System and Laboratory Performance

- 15.1** At the beginning of each 12-hour shift during which analyses are performed, GC/MS system performance and calibration are verified for all native PCBs and labeled compounds. For these tests, analysis of the CS3 calibration verification (VER) standard (Section 7.13 and Table 4) and the congener specificity test standards (Section 7.15 and Table 5) shall be used to verify all performance criteria. Adjustment and/or recalibration (Section 10) shall be performed until all performance criteria are met. Only after all performance criteria are met may samples, blanks, IPRs, and OPRs be analyzed.
- 15.2** MS resolution—A static resolving power of at least 10,000 (10% valley definition) must be demonstrated at the appropriate m/z before any analysis is performed. Static resolving power checks must be performed at the beginning and at the end of each 12-hour shift according to procedures in Section 10.1.2. Corrective actions must be implemented whenever the resolving power does not meet the requirement.
- 15.3** Calibration verification.
- 15.3.1** Inject the VER standard using the procedure in Section 14.
- 15.3.2** The m/z abundance ratios for all PCBs shall be within the limits in Table 9; otherwise, the mass spectrometer shall be adjusted until the m/z abundance ratios fall within the limits specified, and the verification test shall be repeated. If the adjustment alters the resolution of the mass spectrometer, resolution shall be verified (Section 10.1.2) prior to repeat of the verification test.
- 15.3.3** The peaks representing each native PCB and labeled compound in the VER standard must be present with a S/N of at least 10; otherwise, the mass spectrometer shall be adjusted and the verification test repeated.
- 15.3.4** Compute the concentration of each native PCB compound by isotope dilution (Section 17.1) for those compounds that have labeled analogs (Table 1). Compute the concentration of each native compound that does not have a labeled analog and of each labeled compound by the internal standard method (Section 17.2). These concentrations are computed based on the calibration data in Section 10.
- 15.3.5** For each compound, compare the concentration with the calibration verification limit in Table 6. If PCBs 77, 126, and 169 only are to be determined, compare the concentration to the limit in Table 6a. If all compounds meet the acceptance criteria, calibration has been verified and analysis of standards and sample extracts may proceed. If, however, any compound fails its respective limit, the measurement system is not performing properly for that compound. In this event, prepare a fresh calibration standard or correct the problem causing the failure and repeat the resolution (Section 15.2) and verification (Section 15.3) tests, or recalibrate (Section 10).
- 15.4** Retention times and GC resolution.
- 15.4.1** Retention times.
- 15.4.1.1** Absolute—The absolute retention times of the GC/MS internal standards in the verification test (Section 15.3) shall be within ± 15 seconds of the retention times obtained during calibration (Section 10.2.4).

15.4.1.2 Relative—The relative retention times of native PCBs and labeled compounds in the verification test (Section 15.3) shall be within 5 percent of the relative retention times given in Table 2.

15.4.2 GC resolution.

15.4.2.1 Inject the isomer specificity standards (Section 7.15) on their respective columns.

15.4.2.2 The valley height between PCBs 123 and 118 at m/z 325.8804 shall not exceed 10 percent on the SPB-Octyl column, and the valley height between PCBs 156 and 157 shall not exceed 10 percent at m/z 359.8415 on the DB-1 column (Figures 6 and 7).

15.4.3 If the absolute retention time of any compound is not within the limits specified or if the congeners are not resolved, the GC is not performing properly. In this event, adjust the GC and repeat the verification test (Section 15.3) or recalibrate (Section 10), or replace the GC column and either verify calibration or recalibrate.

15.5 Ongoing precision and recovery.

15.5.1 Analyze the extract of the ongoing precision and recovery (OPR) aliquot (Section 11.4.2.5, 11.5.4, 11.6.2, 11.7.4, or 11.8.3.2) prior to analysis of samples from the same batch.

15.5.2 Compute the concentration of each native PCB by isotope dilution for those compounds that have labeled analogs (Section 17.1). Compute the concentration of the native PCBs that have no labeled analog and each labeled compound by the internal standard method (Section 17.2).

15.5.3 For each PCB and labeled compound, compare the concentration to the OPR limits given in Table 6. If PCBs 77, 126, and 169 only are to be determined, compare the concentration to the limits in Table 6a. If all compounds meet the acceptance criteria, system performance is acceptable and analysis of blanks and samples may proceed. If, however, any individual concentration falls outside of the range given, the extraction/concentration processes are not being performed properly for that compound. In this event, correct the problem, re-prepare, extract, and clean up the sample batch and repeat the ongoing precision and recovery test (Section 15.5).

15.5.4 Add results that pass the specifications in Section 15.5.3 to initial and previous ongoing data for each compound in each matrix. Update QC charts to form a graphic representation of continued laboratory performance. Develop a statement of laboratory accuracy for each congener in each matrix type by calculating the average percent recovery (R) and the standard deviation of percent recovery (S_R). Express the accuracy as a recovery interval from $R - 2S_R$ to $R + 2S_R$. For example, if $R = 95\%$ and $S_R = 5\%$, the accuracy is 85 to 105%.

15.6 Blank—Analyze the method blank extracted with each sample batch immediately following analysis of the OPR aliquot to demonstrate freedom from contamination and freedom from carryover from the OPR analysis. The results of the analysis of the blank must meet the specifications in Section 9.5.2 before sample analyses may proceed.

16.0 Qualitative Determination

A PCB or labeled compound is identified in a standard, blank, or sample when all of the criteria in Sections 16.1 through 16.4 are met.

16.1 The signals for the two exact m/z 's in Table 8 must be present and must maximize within the same two seconds.

- 16.2** The signal-to-noise ratio (S/N) for the GC peak at each exact m/z must be greater than or equal to 2.5 for each PCB detected in a sample extract, and greater than or equal to 10 for all PCBs in the calibration standard (Sections 10.2.3 and 15.3.3).
- 16.3** The ratio of the integrated areas of the two exact m/z's specified in Table 8 must be within the limit in Table 9, or within ± 10 percent of the ratio in the midpoint (CS3) calibration or calibration verification (VER), whichever is most recent.
- 16.4** The relative retention time of the peak for a toxic PCB must be within 5 percent of the relative retention times listed in Table 2. The retention time of peaks representing PCBs other than the toxic PCBs must be within the retention time windows established in Section 10.3.
- 16.5** Confirmatory analysis—Isomer specificity for PCBs 156 and 157 cannot be achieved on the SPB-Octyl column. Therefore, any sample in which these PCBs are tentatively identified by analysis on the SPB-Octyl column and when rigorous identification is required must have a confirmatory analysis performed on a DB-1 or equivalent GC column. The operating conditions in Section 10.1.1 may be adjusted to optimize the analysis on the second GC column, but the GC/MS must meet the mass resolution and calibration specifications in Section 10.
- 16.6** If the criteria for identification in Sections 16.1-16.5 are not met, the PCB has not been identified and the results may not be reported for regulatory compliance purposes. If interferences preclude identification, a new aliquot of sample must be extracted, further cleaned up, and analyzed.

17.0 Quantitative Determination

- 17.1** Isotope dilution quantitation—By adding a known amount of a labeled compound to every sample prior to extraction, correction for recovery of the PCB can be made because the native compound and its labeled analog exhibit similar effects upon extraction, concentration, and gas chromatography. Relative response (RR) values are used in conjunction with the initial calibration data described in Section 10.5 to determine concentrations directly, so long as labeled compound spiking levels are constant, using the following equation:

$$C_{ex} \text{ (ng/mL)} = \frac{(AI_n + A2_n) C_l}{(AI_l + A2_l) RR}$$

where:

C_{ex} = The concentration of the PCB in the extract.

The other terms are as defined in Section 10.5.2

Any peaks representing the other congeners are quantitated using an average of the response factors from all of the labeled PCBs isomers at the same level of chlorination.

17.2 Internal standard quantitation and labeled compound recovery.

- 17.2.1** Compute the concentrations of labeled analogs (including the cleanup standard) in the extract using the response factors determined from the initial calibration data (Section 10.6) and the following equation:

$$C_{ex} \text{ (ng/mL)} = \frac{(A1_s + A2_s) C_{is}}{(A1_{is} + A2_{is}) RF}$$

where:

C_{ex} = The concentration of the labeled compound in the extract.

The other terms are as defined in Section 10.6.1

- 17.2.2** Using the concentration in the extract determined above, compute the percent recovery of the labeled compounds (including the cleanup standard) using the following equation:

$$\text{Recovery (\%)} = \frac{\text{Concentration found } (\mu\text{g/mL})}{\text{Concentration spiked } (\mu\text{g/mL})} \times 100$$

- 17.3** The concentration of a native PCB in the solid phase of the sample is computed using the concentration of the compound in the extract and the weight of the solids (Section 11.2.2.3), as follows:

$$\text{Concentration in solid (ng/kg)} = \frac{(C_{ex} \times V_{ex})}{W_s}$$

where:

C_{ex} = The concentration of the compound in the extract.

V_{ex} = The extract volume in mL.

W_s = The sample weight (dry weight) in kg.

- 17.4** The concentration of a native PCB in the aqueous phase of the sample is computed using the concentration of the compound in the extract and the volume of water extracted (Section 11.4), as follows:

$$\text{Concentration in aqueous phase (pg/L)} = \frac{(C_{ex} \times V_{ex})}{V_s}$$

where:

C_{ex} = The concentration of the compound in the extract.

V_{ex} = The extract volume in mL.

V_s = The sample volume in liters.

- 17.5** If the SICP area at either quantitation m/z for any compound exceeds the calibration range of the system, a smaller sample aliquot is extracted.
- 17.5.1** For aqueous samples containing 1% solids or less, dilute 100 mL, 10 mL, etc., of sample to 1 L with reagent water and re-prepare, extract, clean up, and analyze per Sections 11 - 14.
 - 17.5.2** For samples containing greater than 1% solids, extract an amount of sample equal to 1/10, 1/100, etc., of the amount used in Section 11.5.1. Re-prepare, extract, clean up, and analyze per Sections 11-14.
 - 17.5.3** If a smaller sample size will not be representative of the entire sample, dilute the sample extract by a factor of 10, adjust the concentration of the instrument internal standard to 100 pg/ μ L in the extract, and analyze an aliquot of this diluted extract by the internal standard method.
- 17.6** Results are reported to three significant figures for the PCBs and labeled compounds found in all standards, blanks, and samples.
- 17.6.1** Reporting units and levels.
 - 17.6.1.1** Aqueous samples—Report results in pg/L (parts-per-quadrillion).
 - 17.6.1.2** Samples containing greater than 1% solids (soils, sediments, filter cake, compost)—Report results in ng/kg based on the dry weight of the sample. Report the percent solids so that the result may be corrected.
 - 17.6.1.3** Tissues—Report results in ng/kg of wet tissue, not on the basis of the lipid content of the sample. Report the percent lipid content, so that the data user can calculate the concentration on a lipid basis if desired.
 - 17.6.1.4** Reporting level.
 - 17.6.1.4.1** Standards (VER, IPR, OPR) and samples—Report results at or above the minimum level (Table 2). Report results below the minimum level as not detected or as required by the regulatory authority.
 - 17.6.1.4.2** Blanks—Report results above the MDL or as required by the regulatory authority. Do not blank-correct results. If a blank accompanying a sample result shows contamination above the MDL for the congener, flag the sample result and report the results for the sample and the accompanying blank.
 - 17.6.2** Results for PCBs in samples that have been diluted are reported at the least dilute level at which the areas at the quantitation m/z 's are within the calibration range (Section 17.5).
 - 17.6.3** For PCBs having a labeled analog, results are reported at the least dilute level at which the area at the quantitation m/z is within the calibration range (Section 17.5) and the labeled compound recovery is within the normal range for the method (Section 9.3 and Tables 6, 6a, 7, and 7a).
 - 17.6.4** Additionally, if requested, the total concentration of all congeners at a given level of chlorination (i.e., total TCB, total PeCB, total HxCB, etc.) may be reported by summing the concentrations of all congeners identified in that level of chlorination, including both the toxic and other congeners.

18.0 Analysis of Complex Samples

- 18.1** Some samples may contain high levels (>10 ng/L; >1000 ng/kg) of the compounds of interest, interfering compounds, and/or polymeric materials. Some extracts will not concentrate to 10 μ L (Section 12.7); others may overload the GC column and/or mass spectrometer.
- 18.2** Analyze a smaller aliquot of the sample (Section 17.5) when the extract will not concentrate to 10 μ L after all cleanup procedures have been exhausted.
- 18.3** Several laboratories have reported that elimination of several of the toxic PCBs, particularly non-coplanar congeners 105, 114, 118, 123, 156, 157, and 167 is difficult. Backgrounds of these congeners can therefore interfere with the determination of these congeners in environmental samples. Care should therefore be exercised in the determination of these congeners.
- 18.4** Recovery of labeled compounds—In most samples, recoveries of the labeled compounds will be similar to those from reagent water or from the alternate matrix (Section 7.6).
- 18.4.1** If the recovery of any of the labeled compounds is outside of the normal range (Table 7), a diluted sample shall be analyzed (Section 17.5).
- 18.4.2** If the recovery of any of the labeled compounds in the diluted sample is outside of normal range, the calibration verification standard (Section 7.13) shall be analyzed and calibration verified (Section 15.3).
- 18.4.3** If the calibration cannot be verified, a new calibration must be performed and the original sample extract reanalyzed.
- 18.4.4** If the calibration is verified and the diluted sample does not meet the limits for labeled compound recovery, the method does not apply to the sample being analyzed and the result may not be reported for regulatory compliance purposes. In this case, alternate extraction and cleanup procedures in this method must be employed to resolve the interference. If all cleanup procedures in this method have been employed and labeled compound recovery remains outside of the normal range, extraction and/or cleanup procedures that are beyond this scope of this method will be required to analyze these samples.

19.0 Method Performance

For this draft version of Method 1668, performance was validated and preliminary data were collected in a single laboratory.

20.0 Pollution Prevention

- 20.1** The solvents used in this method pose little threat to the environment when managed properly. The solvent evaporation techniques used in this method are amenable to solvent recovery, and it is recommended that the laboratory recover solvents wherever feasible.
- 20.2** Standards should be prepared in volumes consistent with laboratory use to minimize disposal of standards.

21.0 Waste Management

- 21.1** It is the laboratory's responsibility to comply with all federal, state, and local regulations governing waste management, particularly the hazardous waste identification rules and land disposal restrictions, and to protect the air, water, and land by minimizing and controlling all releases from fume hoods and bench operations. Compliance is also required with any sewage discharge permits and regulations.
- 21.2** Samples containing HCl or H₂SO₄ to pH <2 are hazardous and must be neutralized before being poured down a drain or must be handled as hazardous waste.
- 21.3** The PCBs decompose above 800°C. Low-level waste such as absorbent paper, tissues, animal remains, and plastic gloves may be burned in an appropriate incinerator. Gross quantities (milligrams) should be packaged securely and disposed of through commercial or governmental channels that are capable of handling extremely toxic wastes.
- 21.4** [This section may need to be modified to accommodate the PCBs: Liquid or soluble waste should be dissolved in methanol or ethanol and irradiated with ultraviolet light with a wavelength shorter than 290 nm for several days. Use F40 BL or equivalent lamps. Analyze liquid wastes, and dispose of the solutions when the PCBs can no longer be detected.]
- 21.5** For further information on waste management, consult "The Waste Management Manual for Laboratory Personnel" and "Less is Better—Laboratory Chemical Management for Waste Reduction," available from the American Chemical Society's Department of Government Relations and Science Policy, 1155 16th Street N.W., Washington, D.C. 20036.

22.0 References

- 1 Kuehl, D.W., B.C. Butterworth, J. Libal, and P. Marquis, "An Isotope Dilution High Resolution Gas Chromatographic-High Resolution Mass Spectrometric Method for the Determination of Coplanar Polychlorinated Biphenyls: Application to Fish and Marine Mammals," *Chemosphere* 22:9-10, 849-858, 1991.
- 2 Feltz, Kevin P., Donald E. Tillitt, Robert W. Gale, Paul H. Peterman, *Environ. Sci. Tech.* TBD.
- 3 "Analysis of Coplanar PCBs," Axys Environmental Systems Ltd., Fax from Mary McFarland to Dale Rushneck dated November 25, 1994, available from the EPA Sample Control Center, operated by DynCorp I&ET, 300 N. Lee St, Alexandria, VA 22314.
- 4 Ahlborg, U.G., G.C. Becking, L.S. Birnbaum, A. Brouwer, H.J.G.M. Derks, M. Feeley, G. Golor, A. Hanberg, J.C. Larsen, A.K.D. Liem, S.H. Safe, C. Schlatter, F. Waern, M. Younes, and E. Yrjänheikki, "Toxic Equivalency Factors for Dioxin-like PCBs," *Chemosphere* 28:6, 1049-1067, 1994.
- 5 "Working with Carcinogens," Department of Health, Education, & Welfare, Public Health Service, Centers for Disease Control, NIOSH, Publication 77-206, August 1977, NTIS PB-277256.
- 6 "OSHA Safety and Health Standards, General Industry," OSHA 2206, 29 *CFR* 1910.
- 7 "Safety in Academic Chemistry Laboratories," ACS Committee on Chemical Safety, 1979.
- 8 "Standard Methods for the Examination of Water and Wastewater," 18th edition and later revisions, American Public Health Association, 1015 15th St, N.W., Washington, DC 20005, 1-35: Section 1090 (Safety), 1992.

-
- 9 "Method 613—2,3,7,8-Tetrachlorodibenzo-*p*-dioxin," 40 *CFR* 136 (49 *FR* 43234), October 26, 1984, Section 4.1.
 - 10 Lamparski, L.L., and Nestruck, T.J., "Novel Extraction Device for the Determination of Chlorinated Dibenzo-*p*-dioxins (PCDDs) and Dibenzofurans (PCDFs) in Matrices Containing Water," *Chemosphere*, 19:27-31, 1989.
 - 11 Provost, L.P., and Elder, R.S., "Interpretation of Percent Recovery Data," *American Laboratory*, 15: 56-83, 1983.
 - 12 "Standard Practice for Sampling Water," ASTM Annual Book of Standards, ASTM, 1916 Race Street, Philadelphia, PA 19103-1187, 1980.
 - 13 "Methods 330.4 and 330.5 for Total Residual Chlorine," USEPA, EMSL, Cincinnati, OH 45268, EPA 600/4-70-020, March 1979.
 - 14 "Handbook of Analytical Quality Control in Water and Wastewater Laboratories," USEPA EMSL, Cincinnati, OH 45268, EPA-600/4-79-019, March 1979.
 - 15 "Analytical Procedures and Quality Assurance Plan for the Determination of PCDD/PCDF in Fish", U.S. Environmental Protection Agency, Environmental Research Laboratory, Duluth MN 55804, EPA/600/3-90/022, March 1990.
 - 16 Storr-Hansen, E. and T. Cederberg, "Determination of Coplanar Polychlorinated Biphenyl (CB) Congeners in Seal Tissues by Chromatography on Active Carbon, Dual-Column High Resolution GC/ECD and High Resolution GC/High Resolution MS" *Chemosphere* 24:9, 1181-1196, 1992.
 - 17 Workman, S.M., TBD [or Peterman in Reference 2]
 - 18 Tessari, J.D., Personal communication with Dale Rushneck, available from the EPA Sample Control Center, operated by DynCorp I&ET, 300 N. Lee St., Alexandria, VA 22314 (703-519-1140).

23.0 Tables and Figures

Table 1. Toxic Polychlorinated Biphenyls Determined by Isotope Dilution and Internal Standard High Resolution Gas Chromatography (HRGC)/High Resolution Mass Spectrometry (HRMS)

PCB ¹	Native compound CAS Registry No.	IUPAC No.	¹³ C ₁₂ analog CAS Registry No.
3,3',4,4'-TCB	32598-13-3	77	160901-67-7
2,3,3',4,4'-PeCB	32598-14-4	105	160901-70-2
2,3,4,4',5-PeCB	74472-37-0	114	160901-72-4
2,3',4,4',5-PeCB	31508-00-6	118	160901-73-5
2',3,4,4',5-PeCB	65510-44-3	123	160901-74-6
3,3',4,4',5-PeCB	57465-28-8	126	160901-75-7
2,3,3',4,4',5-HxCB	38380-08-4	156	160901-77-9
2,3,3',4,4',5'-HxCB	69782-90-7	157	160901-78-0
2,3',4,4',5,5'-HxCB	52663-72-6	167	161627-18-5
3,3',4,4',5,5'-HxCB	32774-16-6	169	160901-79-1
2,2',3,3',4,4',5-HpCB	35065-30-6	170	160901-80-4
2,2',3,4,4',5,5'-HpCB	35065-29-3	180	160901-82-6
2,3,3',4,4',5,5'-HpCB	39635-31-9	189	160901-83-7
Cleanup standards			
¹³ C ₁₂ -3,4,4',5-TCB		81	160901-68-8
¹³ C ₁₂ -2,3,3',5,5'-PeCB		111	160901-71-3
Internal standards			
¹³ C ₁₂ -2,2',5,5'-TCB		52	160901-66-6
¹³ C ₁₂ -2,2',4,4',5'-PeCB		101	160901-69-9
¹³ C ₁₂ -2,2',3,4,4',5'-HxCB		138	160901-76-8
¹³ C ₁₂ -2,2',3,3',5,5',6-HpCB		178	160901-81-5
Final eluter standard			
¹³ C ₁₂ -DCB		209	160901-84-8

¹ Polychlorinated biphenyls:

TCB= Tetrachlorobiphenyl
 PeCB = Pentachlorobiphenyl
 HxCB = Hexachlorobiphenyl
 HpCB = Heptachlorobiphenyl
 DCB = Decachlorobiphenyl

Table 2. Retention Time (RT) References, Quantitation References, Relative Retention Times (RRTs), Estimated Method Detection Limits (EMDLs), and Estimated Minimum Levels (EMLs) for the Toxic PCBs^a

IUPAC ¹ No.	Labeled or native PCB	IUPAC ¹ No.	Retention time and quantitation reference	RT (min) ²	RRT	Matrix and Concentration				
						Water (pg/l) EMDL	EML	Other (ng/Kg) EMDL	EML	Extract (pg/μL) EML
52L	13C12-2,2',5,5'-TCB	52L	13C12-2,2',5,5'-TCB	12.87	1.000					
81L	13C12-3,4,4',5'-TCB ⁴	52L	13C12-2,2',5,5'-TCB	19.65	1.527					
77L	13C12-3,3',4,4'-TCB	52L	13C12-2,2',5,5'-TCB	20.15	1.566					
77	3,3',4,4'-TCB	77L	13C12-3,3',4,4'-TCB	20.18	1.002	5	20	0.5	2	1
Penta congeners using 13C12-2,2',4,5,5'-PeCB (#101L) as the injection internal standard										
101L	13C12-2,2',4,5,5'-PeCB	101L	13C12-2,2',4,5,5'-PeCB	17.83	1.000					
111L	13C12-2,3,3',5,5'-PeCB ⁴	101L	13C12-2,2',4,5,5'-PeCB	20.12	1.128					
123	2',3,4,4',5-PeCB	118L	13C12-2,3',4,4',5-PeCB	21.98	0.987	40	100	4	10	5
118L	13C12-2,3',4,4',5-PeCB	101L	13C12-2,2',4,5,5'-PeCB	22.27	1.249					
118	2,3',4,4',5-PeCB	118L	13C12-2,3',4,4',5-PeCB	22.30	1.001	60	200	6	20	10
114	2,3,4,4',5-PeCB	105L	13C12-2,3,3',4,4'-PeCB	22.82	0.974	600	2000	60	200	100
105L	13C12-2,3,3',4,4'-PeCB	101L	13C12-2,2',4,5,5'-PeCB	23.42	1.313					
105	2,3,3',4,4'-PeCB	105L	13C12-2,3,3',4,4'-PeCB	23.43	1.000	400	1000	40	100	50
126L	13C12-3,3',4,4',5-PeCB	101L	13C12-2,2',4,5,5'-PeCB	26.55	1.489					
126	3,3',4,4',5-PeCB	126L	13C12-3,3',4,4',5-PeCB	26.56	1.000	40	100	10	4	5
Hexa congeners using 13C12-2,2',3,4,4',5'-HxCB (#138L) as the injection internal standard										
138L	13C12-2,2',3,4,4',5'-HxCB	101L	13C12-2,2',4,5,5'-PeCB	25.35	1.422					
167L	13C12-2,3',4,4',5,5'-HxCB	138L	13C12-2,2',3,4,4',5'-HxCB	28.50	1.124					
167	2,3',4,4',5,5'-HxCB	167L	13C12-2,3',4,4',5,5'-HxCB	28.52	1.001	60	200	6	20	10
156L	13C12-2,3,3',4,4',5-HxCB	138L	13C12-2,2',3,4,4',5'-HxCB	29.77	1.174					
157L	13C12-2,3,3',4,4',5'-HxCB	138L	13C12-2,2',3,4,4',5'-HxCB	29.77	1.174					
156	2,3,3',4,4',5-HxCB	156L	13C12-2,3,3',4,4',5-HxCB	29.80	1.001	60	200	6	20	10
157	2,3,3',4,4',5'-HxCB	157L	13C12-2,3,3',4,4',5'-HxCB	29.80	1.001	60	200	6	20	10
169L	13C12-3,3',4,4',5,5'-HxCB	138L	13C12-2,2',3,4,4',5'-HxCB	33.38	1.317					
169	3,3',4,4',5,5'-HxCB	169L	13C12-3,3',4,4',5,5'-HxCB	33.42	1.001	60	200	6	20	10

^a Continued on next page

Table 2. (cont.) Retention Time (RT) References, Quantitation References, Relative Retention Times (RRTs), Estimated Method Detection Limits (EMDLs), and Estimated Minimum Levels (EMLs) for the Toxic PCBs

IUPAC ¹ No.	Labeled or native PCB	IUPAC ¹ No.	Retention time and quantitation reference	RT (min) ²	RRT	Matrix and Concentration				
						Water (pg/l)		Other (ng/Kg)		Extract (pg/μL)
						EMDL	EML	EMDL	EML	EML
Hepta and deca congeners using 13C12-2,2',3,3',5,5',6-HpCB (#178L) as the injection internal standard										
178L	13C12-2,2',3,3',5,5',6-HpCB	101L	13C12-2,2',4,5,5'-PeCB	25.78	1.446					
180L	13C12-2,2',3,4,4',5,5'-HpCB	178L	13C12-2,2',3,3',5,5',6-HpCB	31.30	1.214					
180	2,2',3,4,4',5,5'-HpCB	180L	13C12-2,2',3,4,4',5,5'-HpCB	31.32	1.001	60	200	6	20	10
170	2,2',3,3',4,4',5-HpCB	180L	13C12-2,2',3,4,4',5,5'-HpCB	32.75	1.046	60	200	6	20	10
189L	13C12-2,3,3',4,4',5,5'-HpCB	178L	13C12-2,2',3,3',5,5',6-HpCB	36.32	1.409					
189	2,3,3',4,4',5,5'-HpCB	189L	13C12-2,3,3',4,4',5,5'-HpCB	36.35	1.001	60	200	6	20	10
209L	13C12-DCB ⁵	178L	13C12-2,2',3,3',5,5',6-HpCB	43.48	1.687					

¹ Suffix "L" indicates labeled compound

² Retention time data are for SPB-octyl column sorted in ascending retention time order within each congener group

³ Some EMDLs and EMLs have been set above the lowest calibration point (Table 4) because backgrounds of these particular congeners are difficult to eliminate from laboratory analytical systems

⁴ Cleanup standard

⁵ Final eluter

Table 3. Concentrations of Stock and Spiking Solutions Containing the Native PCBs and Labeled Compou

PCB congener	IUPAC No.	Labeled compound		Precision and Recovery	
		Stock ¹ (ng/mL)	Spiking ² (ng/mL)	Stock ³ (ng/mL)	Spiking ⁴ (ng/mL)
3,3',4,4'-TCB	77	-	-	220	0.4
2,3,3',4,4'-PeCB	105	-	-	1000	20.0
2,3,4,4',5'-PeCB	114	-	-	1000	20.0
2,3',4,4',5'-PeCB	118	-	-	1000	20.0
2',3,4,4',5'-PeCB	123	-	-	1000	20.0
3,3',4,4',5'-PeCB	126	-	-	100	2.0
2,3,3',4,4',5'-HxCB	156	-	-	1000	20.0
2,3,3',4,4',5'-HxCB	157	-	-	1000	20.0
2,3',4,4',5,5'-HxCB	167	-	-	1000	20.0
3,3',4,4',5,5'-HxCB	169	-	-	200	4.0
2,2',3,3',4,4',5'-HpCB	170	-	-	200	4.0
2,2',3,4,4',5,5'-HpCB	180	-	-	1000	20.0
2,3,3',4,4',5,5'-HpCB	189	-	-	200	4.0
13C12-3,3',4,4'-TCB	77L	1000	2.0	-	-
13C12-2,3,3',4,4'-PeCB	105L	1000	2.0	-	-
13C12-2,3',4,4',5'-PeCB	118L	1000	2.0	-	-
13C12-3,3',4,4',5'-PeCB	126L	1000	2.0	-	-
13C12-2,3,3',4,4',5'-HxCB	156L	1000	2.0	-	-
13C12-2,3,3',4,4',5'-HxCB	157L	1000	2.0	-	-
13C12-2,3',4,4',5,5'-HxCB	167L	1000	2.0	-	-
13C12-3,3',4,4',5,5'-HxCB	169L	1000	2.0	-	-
13C12-2,2',3,4,4',5,5'-HpCB	180L	1000	2.0	-	-
13C12-2,3,3',4,4',5,5'-HpCB	189L	1000	2.0	-	-
13C12-DCB	209L	2000	4.0	-	-
Cleanup standards⁵					
13C12-3,4,4',5'-TCB	81L	200	1.0	-	-
13C12-2,3,3',5,5'-PeCB	111L	1000	5.0	-	-
Internal standards⁶					
13C12-2,2',5,5'-TCB	52L	1000	-	-	-
13C12-2,2',4,5,5'-PeCB	101L	1000	-	-	-
13C12-2,2',3,4,4',5'-HxCB	138L	1000	-	-	-
13C12-2,2',3,3',5,5',6'-HpCB	178L	1000	-	-	-

¹ Section 7.10-prepared in nonane and diluted to prepare spiking solution

² Section 7.10.3-prepared in acetone from stock solution daily

³ Section 7.9-prepared in nonane and diluted to prepare spiking solution. Concentrations are adjusted for expected background

⁴ Section 7.14-prepared in acetone from stock solution daily. Concentrations are adjusted for expected background levels.

⁵ Section 7.11-prepared in nonane and added to extract prior to cleanup

⁶ Section 7.12-prepared in nonane and added to concentrated extract prior to injection

Table 4. Concentrations of PCBs in Calibration and Calibration Verification Solutions

Toxic PCB congener	IUPAC ¹ No.	CS1 (ng/mL)	CS2 (ng/mL)	CS3 ² (ng/mL)	CS4 (ng/mL)	CS5 (ng/mL)
3,3',4,4'-TCB	77	0.5	2	10	40	200
2,3,3',4,4'-PeCB	105	2.5	10	50	200	1000
2,3,4,4',5'-PeCB	114	2.5	10	50	200	1000
2,3',4,4',5'-PeCB	118	2.5	10	50	200	1000
2',3,4,4',5'-PeCB	123	2.5	10	50	200	1000
3,3',4,4',5'-PeCB	126	2.5	10	50	200	1000
2,3,3',4,4',5'-HxCB	156	5	20	100	400	2000
2,3,3',4,4',5'-HxCB	157	5	20	100	400	2000
2,3',4,4',5,5'-HxCB	167	5	20	100	400	2000
3,3',4,4',5,5'-HxCB	169	5	20	100	400	2000
2,2',3,3',4,4',5'-HpCB	170	5	20	100	400	2000
2,2',3,4,4',5,5'-HpCB	180	5	20	100	400	2000
2,3,3',4,4',5,5'-HpCB	189	5	20	100	400	2000
Labeled congener						
13C12-3,3',4,4'-TCB	77L	100	100	100	100	100
13C12-2,3,3',4,4'-PeCB	105L	100	100	100	100	100
13C12-2,3',4,4',5'-PeCB	118L	100	100	100	100	100
13C12-3,3',4,4',5'-PeCB	126L	100	100	100	100	100
13C12-2,3,3',4,4',5'-HxCB	156L	100	100	100	100	100
13C12-2,3,3',4,4',5'-HxCB	157L	100	100	100	100	100
13C12-3,3',4,4',5,5'-HxCB	169L	100	100	100	100	100
13C12-2,2',3,4,4',5,5'-HpCB	180L	100	100	100	100	100
13C12-2,3,3',4,4',5,5'-HpCB	189L	100	100	100	100	100
13C12-DCB	209L	200	200	200	200	200
Cleanup standards						
13C12-3,4,4',5'-TCB	81L	0.5	2	10	40	200
13C12-2,3,3',5,5'-PeCB	111L	2.5	10	50	200	1000
Internal standards						
13C12-2,2',5,5'-TCB	52L	100	100	100	100	100
13C12-2,2',4,5,5'-PeCB	101L	100	100	100	100	100
13C12-2,2',3,4,4',5'-HxCB	138L	100	100	100	100	100
13C12-2,2',3,3',5,5',6'-HpCB	178L	100	100	100	100	100

¹ Suffix "L" indicates labeled compound² Section 15.3, calibration verification solution

Table 5. GC Retention Time Window Defining Solution and Congener Specificity Test Standard^{1,2} (Section 7.15)

Congener Group	First eluted³		Last eluted	
TCB	54	2,2',6,6'	77	3,3',4,4'
PeCB	104	2,2',4,6,6'	126	3,3',4,4',5
HxCB	155	2,2',4,4',6,6'	169	3,3',4,4',5,5'
HpCB	188	2,2',3,4',5,6,6'	189	2,3,3',4,4',5,5'

SPB-Octyl resolution test compounds

123 2',3,4,4',5-PeCB

118 2,3',4,4',5-PeCB

114 2,3,4,4',5-PeCB

DB-1 column resolution test compounds

156 2,3,3',4,4',5-HxCB

157 2,3,3',4,4',5'-HxCB

¹ All compounds are at a concentration of 100 ng/mL in nonane.² It is not necessary to monitor for the earliest eluted compounds if the toxic PCBs only are to be determined. If the co-planar PCBs (77, 126, 169) only are to be determined, it is necessary to resolve these co-planar PCBs and potent interfering compounds only; i.e., use of the compounds listed in this Table is not required.³ The earliest eluted compound in each congener group is provided for those instances in which all PCBs in that congener group are to be determined. If the toxic PCBs only (Table 1) are to be determined, use of the first eluted compound is not required.

Table 6. Preliminary Acceptance Criteria for Performance Tests When All Toxic PCBs are Tested

Congener	IUPAC No.	Test (ng/mL)	IPR		OPR (ng/mL)	VER (ng/mL)
			s ² (ng/mL)	X ³ (ng/mL)		
3,3',4,4'-TCB	77	20	5.6	16-26	14-32	16-26
2,3,3',4,4'-PeCB	105	1000	172	720-1500	680-1600	780-1300
2,3,4,4',5-PeCB	114	1000	390	160-2800	130-3300	770-1300
2,3',4,4',5-PeCB	118	1000	172	720-1500	680-1600	780-1300
2',3,4,4',5-PeCB	123	1000	390	160-2800	130-3300	770-1300
3,3',4,4',5-PeCB	126	100	17	72-150	68-160	78-130
2,3,3',4,4',5-HxCB	156	1000	222	740-1600	640-1700	780-1300
2,3,3',4,4',5'-HxCB	157	1000	222	740-1600	640-1700	780-1300
2,3',4,4',5,5'-HxCB	167	1000	222	740-1600	640-1700	780-1300
3,3',4,4',5,5'-HxCB	169	200	45	148-320	128-340	156-260
2,2',3,3',4,4',5-HpCB	170	200	33	152-260	140-280	172-232
2,2',3,4,4',5,5'-HpCB	180	1000	165	760-1300	700-1400	860-1160
2,3,3',4,4',5,5'-HpCB	189	200	33	152-260	140-280	172-232
13C12-3,3',4,4'-TCB	77L	100	37	28-134	20-175	71-140
13C12-2,3,3',4,4'-PeCB	105L	100	39	16-279	13-328	77-130
13C12-2,3',4,4',5-PeCB	118L	100	39	16-279	13-328	77-130
13C12-3,3',4,4',5-PeCB	126L	100	39	16-279	13-328	77-130
13C12-2,3,3',4,4',5-HxCB	156L	100	34	24-157	17-205	70-143
13C12-2,3,3',4,4',5'-HxCB	157L	100	43	24-157	17-205	70-143
13C12-3,3',4,4',5,5'-HxCB	169L	100	43	24-157	17-205	70-143
13C12-2,2',3,4,4',5,5'-HpCB	180L	100	41	28-141	20-186	72-138
13C12-2,3,3',4,4',5,5'-HpCB	189L	200	82	56-282	40-372	144-276
Cleanup standards						
13C12-3,4,4',5-TCB	81L	20	7.2	8-31	6-38	15-26
13C12-2,3,3',5,5'-PeCB	111L	100	36	39-154	31-191	79-127

Table 6a. Preliminary Acceptance Criteria for Performance Tests when PCBs 77, 126, and 169 only : Tested¹

Native PCB	IUPAC	Test (ng/mL)	IPR		OPR (ng/mL)	VER (ng/mL)
			s ² (ng/mL)	X ³ (ng/mL)		
3,3',4,4'-TCB	77	20	5.4	17-25	15-30	16-25
3,3',4,4',5-PeCB	126	100	17	72-150	68-160	78-130
3,3',4,4',5,5'-HxCB	169	200	45	148-320	128-340	156-260
13C12-3,3',4,4'-TCB	77L	100	34	32-115	25-141	76-131
13C12-3,3',4,4',5-PeCB	126L	100	17	72-150	68-160	78-130
13C12-3,3',4,4',5,5'-HxCB	169L	200	45	148-320	128-340	156-260
Cleanup standards						
13C12-3,4,4',5-TCB	81L	20	7.2	8-31	6-38	15-26
13C12-2,3,3',5,5'-PeCB	111L	100	36	39-154	31-191	79-127

¹ Preliminary criteria transferred from Method 1613. All criteria given as concentration in the final extract, assuming a 20- μ L volume.

² s=standard deviation

³ X=average concentration

Table 7. Labeled Compound Recovery in Samples When All PCBs are Tested

Labeled PCB	IUPAC No.	Test conc (ng/mL)	Labeled compound recovery (ng/mL)	(%)
13C12-3,3',4,4'-TCB	77	100	24-169	24-169
13C12-2,3,3',4,4'-PeCB	105	100	21-178	21-178
13C12-2,3',4,4',5-PeCB	118	100	21-178	21-178
13C12-3,3',4,4',5-PeCB	126	100	21-178	21-178
13C12-2,3,3',4,4',5-HxCB	156	100	26-152	26-152
13C12-2,3,3',4,4',5'-HxCB	157	100	26-152	26-152
13C12-2,3',4,4',5,5'-HxCB	167	100	26-152	26-152
13C12-3,3',4,4',5,5'-HxCB	169	100	26-152	26-152
13C12-2,2',3,4,4',5,5'-HpCB	180	100	23-143	23-143
13C12-2,3,3',4,4',5,5'-HpCB	189	100	23-143	23-143
Cleanup standards				
13C12-3,4,4',5-TCB	81	20	7-40	35-197
13C12-2,3,3',5,5'-PeCB	111	100	35-197	35-197

Table 7a. Labeled Compound Recovery When PCBs 77, 126, and 169 Only are Tested¹

Labeled PCB	IUPAC No.	Test conc (ng/mL)	Labeled compound Recovery (ng/mL)	(%)
13C12-3,3',4,4'-TCB	77	100	29-140	29-140
13C12-3,3',4,4',5-PeCB	126	100	21-178	21-178
13C12-3,3',4,4',5,5'-HxCB	169	100	26-152	26-152
Cleanup standards				
13C12-3,4,4',5-TCB	81	20	8-33	42-164
13C12-2,3,3',5,5'-PeCB	111	100	35-197	35-197

¹ Preliminary criteria transferred from Method 1613. Criteria are given as concentration in the final extract, assuming 20 uL volume.

Table 8. Descriptors, Exact m/z's, m/z Types, and Elemental Compositions of the PCBs

Descriptor	Exact m/z ¹	m/z type	Elemental composition	Substance ²
1.	289.9224	M	C12 H6 35Cl4	TCB
	291.9194	M+2	C12 H6 35Cl3 37Cl4	TCB
	292.9825	Lock	C7 F11	PFK
	301.9626	M	¹³ C12 H6 35Cl4	PeCB ³
	303.9597	M+2	¹³ C12 H6 35Cl3 37Cl	PeCB ³
	325.8804	M+2	C12 H5 35Cl4 37Cl	PeCB
	327.8775	M+4	C12 H5 35Cl3 37Cl2	PeCB
	330.9792	QC	C7 F13	PFK
2.	325.8804	M+2	C12 H5 35Cl4 37Cl	PeCB
	327.8775	M+4	C12 H5 35Cl3 37Cl2	PeCB
	337.9207	M+2	¹³ C12 H5 35Cl4 37Cl	PeCB ³
	339.9178	M+4	¹³ C12 H5 35Cl3 37Cl2	PeCB ³
	354.9892	Lock	C9 F13	PFK
	359.8415	M+2	C12 H4 35Cl5 37Cl	HxCB
	361.8385	M+4	C12 H4 35Cl4 37Cl2	HxCB
	371.8817	M+2	¹³ C12 H4 35Cl5 37Cl	HxCB ³
	373.8788	M+4	¹³ C12 H4 35Cl4 37Cl2	HxCB ³
	393.8025	M+2	C12 H3 35Cl6 37Cl	HpCB
	395.7996	M+4	C12 H3 35Cl5 37Cl2	HpCB
	405.8428	M+2	¹³ C12 H3 35Cl6 37Cl	HpCB ³
	407.8398	M+4	¹³ C12 H3 35Cl5 37Cl2	HpCB ³
	3.	442.9728	Lock	C10 F17
509.7229		M+4	¹³ C12 35Cl10 37Cl2	DCB ³
511.7199		M+6	¹³ C12 35Cl9 37Cl3	DCB ³
513.7170		M+8	¹³ C12 35Cl8 37Cl4	DCB ³

¹ Nuclidic masses used were:

H = 1.007825 C = 12.00000

¹³C = 13.003355 ³⁵Cl = 34.968853 ³⁷Cl = 36.965903

² TCB =Tetrachlorobiphenyl

PeCB = Pentachlorobiphenyl

HxCB = Hexachlorobiphenyl

HpCB = Heptachlorobiphenyl

DCB =Decachlorobiphenyl

³ ¹³C labeled compound

Table 9. Theoretical Ion Abundance Ratios and QC Limits

Clorine atoms	m/z's forming ratio	Theoretical ratio	QC Limit ¹	
			Lower	Upper
4	M/(M+2)	0.77	0.65	0.89
5	(M+2)/(M+4)	1.55	1.32	1.78
6	M/(M+2)	0.51	0.43	0.59
6	(M+2)/(M+4)	1.24	1.05	1.43
7	M/(M+2)	0.44	0.37	0.51
7	(M+2)/(M+4)	1.05	0.88	1.20
8	(M+2)/(M+4)	0.89	0.76	1.02

¹ QC limits represent +/- 15 % windows around the theoretical ion abundance ratio. These limits are preliminary.

Table 10. Suggested Sample Quantities to be Extracted for Various Matrices¹

Sample matrix ²	Example	Percent solids	Phase	Quantity extracted
Single-phase				
Aqueous	Drinking water Groundwater Treated wastewater	<1	— ³	1000 mL
Solid	Dry soil Compost Ash	>20	Solid	10 g
Organic	Waste solvent Waste oil Organic polymer	<1	Organic	10 g
Tissue	Fish Human adipose	—	Organic	10 g
Multi-phase				
Liquid/Solid				
Aqueous/Solid	Wet soil Untreated effluent Digested municipal sludge Filter cake Paper pulp	1–30	Solid	10 g
Organic/solid	Industrial sludge Oily waste	1–100	Both	10 g
Liquid/Liquid				
Aqueous/organic	In-process effluent Untreated effluent Drum waste	<1	Organic	10 g
Aqueous/organic/solid	Untreated effluent Drum waste	>1	Organic & solid	10 g

¹ The quantity of sample to be extracted is adjusted to provide 10 g of solids (dry weight). One liter of aqueous samples containing one percent solids will contain 10 grams of solids. For aqueous samples containing greater than one percent solids, a lesser volume is used so that 10 grams of solids (dry weight) will be extracted.

² The sample matrix may be amorphous for some samples. In general, when the PCBs are in contact with a multiphase system in which one of the phases is water, they will be preferentially dispersed in or adsorbed on the alternate phase because of their low solubility in water.

³ Aqueous samples are filtered after spiking with the labeled compounds. The filtrate and the materials trapped on the filter are extracted separately, and the extracts are combined for cleanup and analysis.

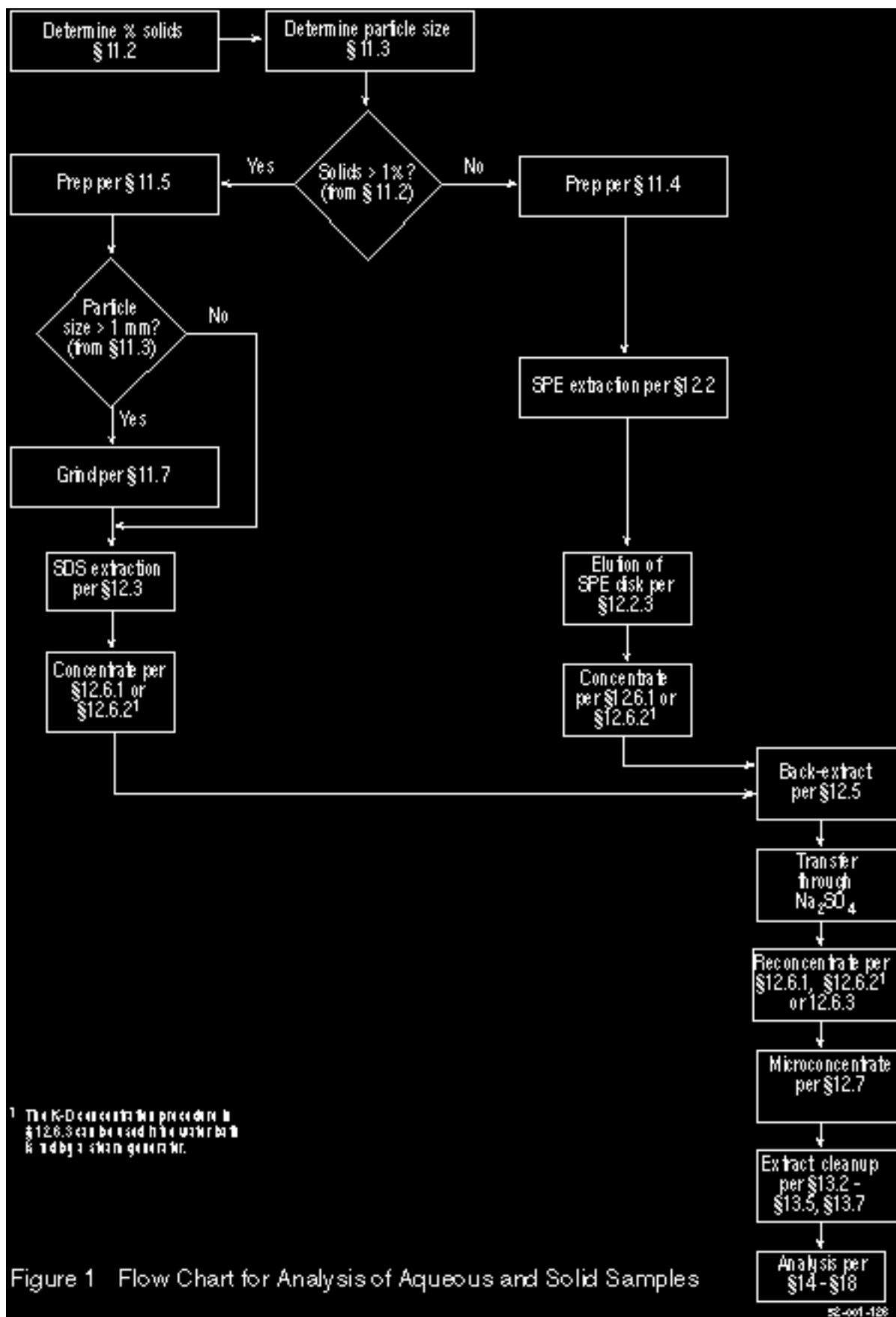

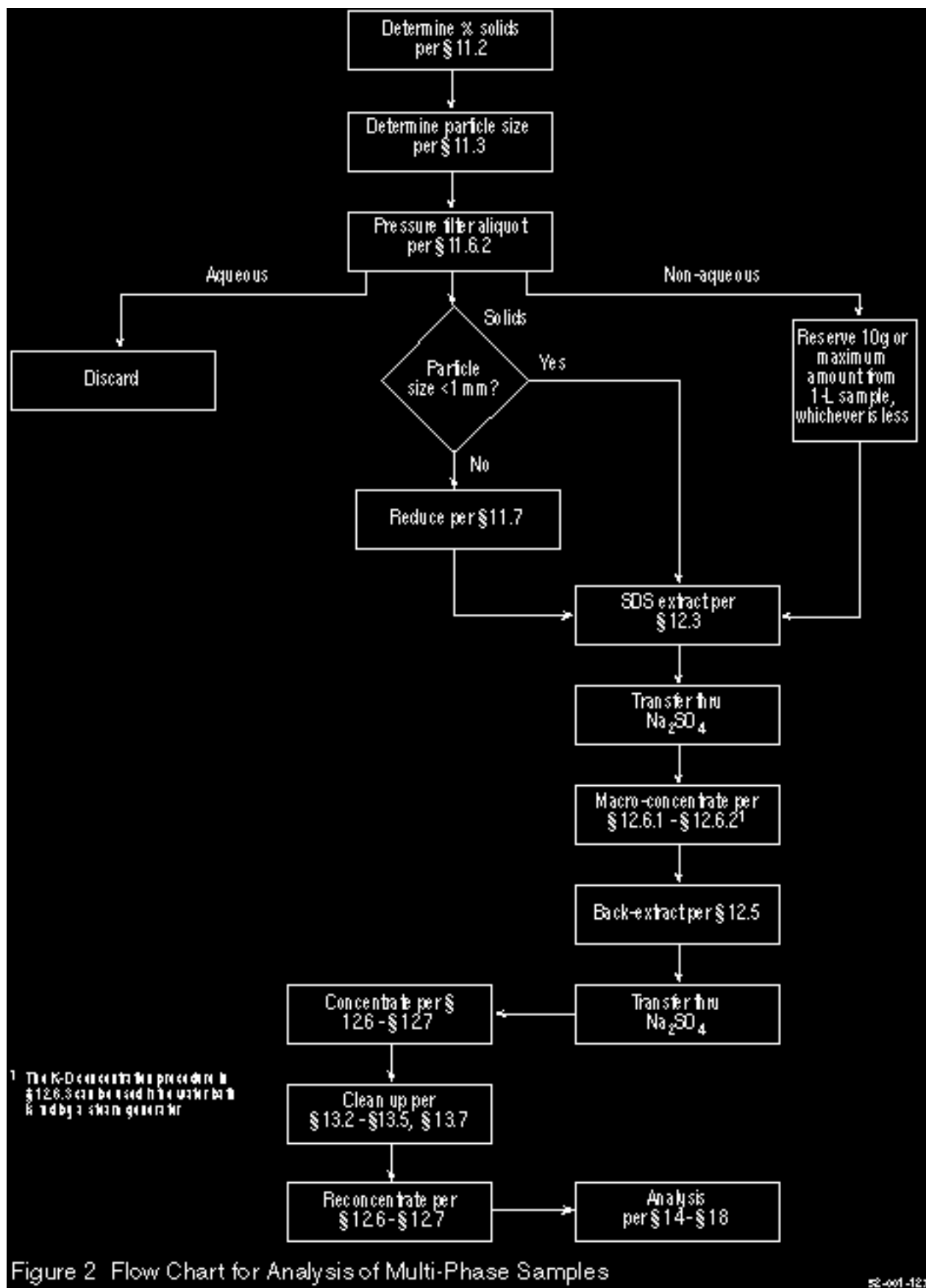

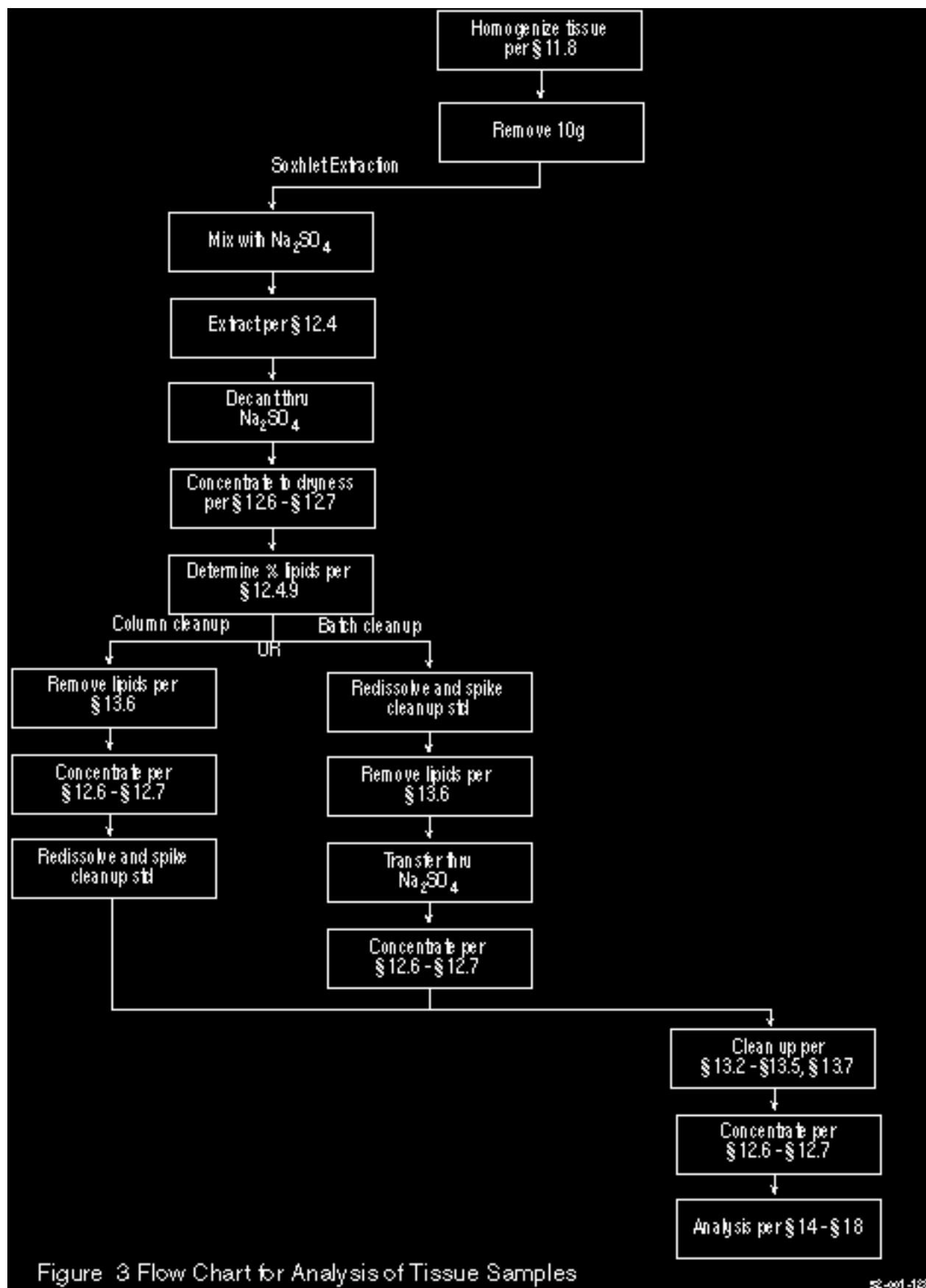

Figure 3 Flow Chart for Analysis of Tissue Samples

§2-001-128

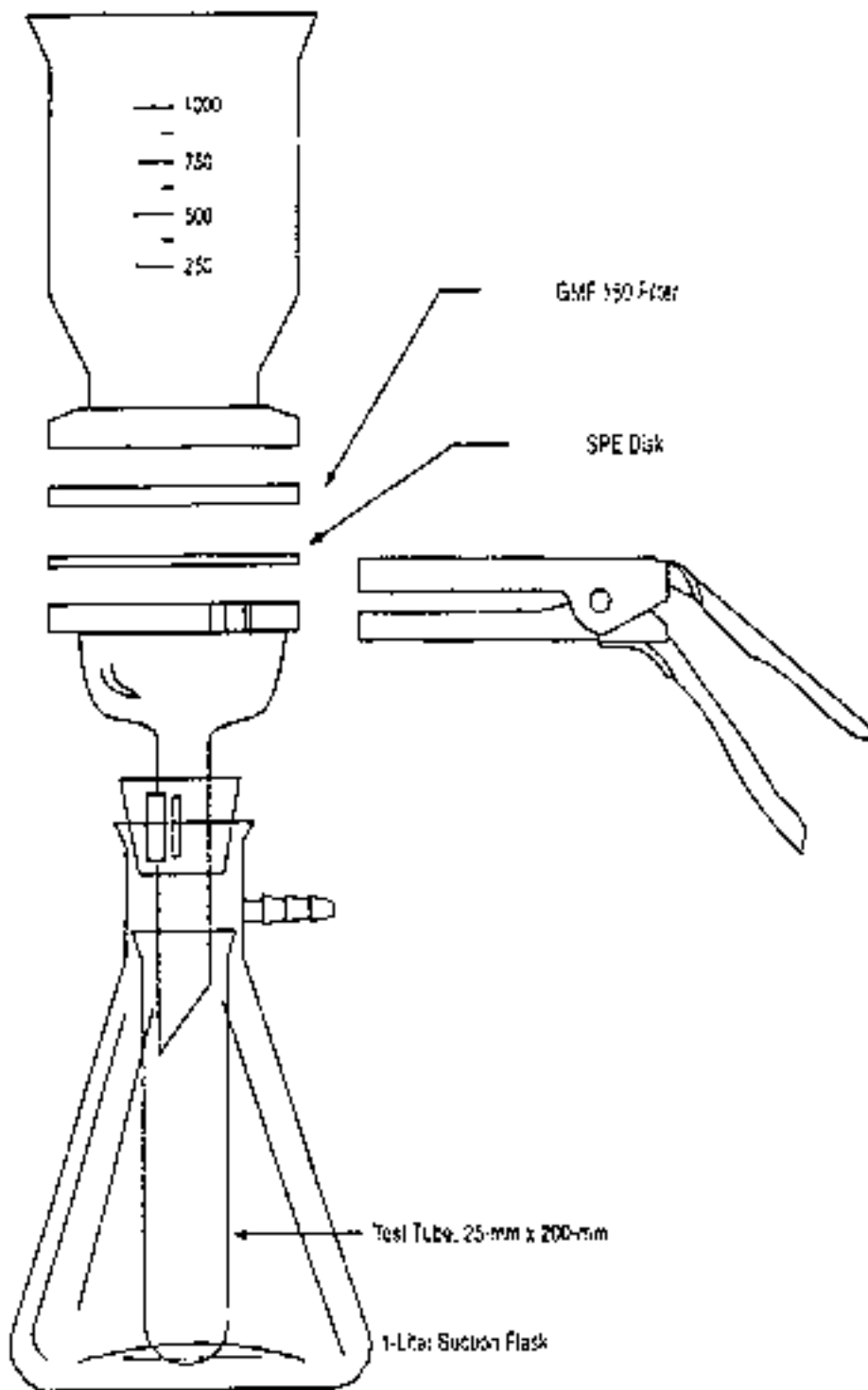
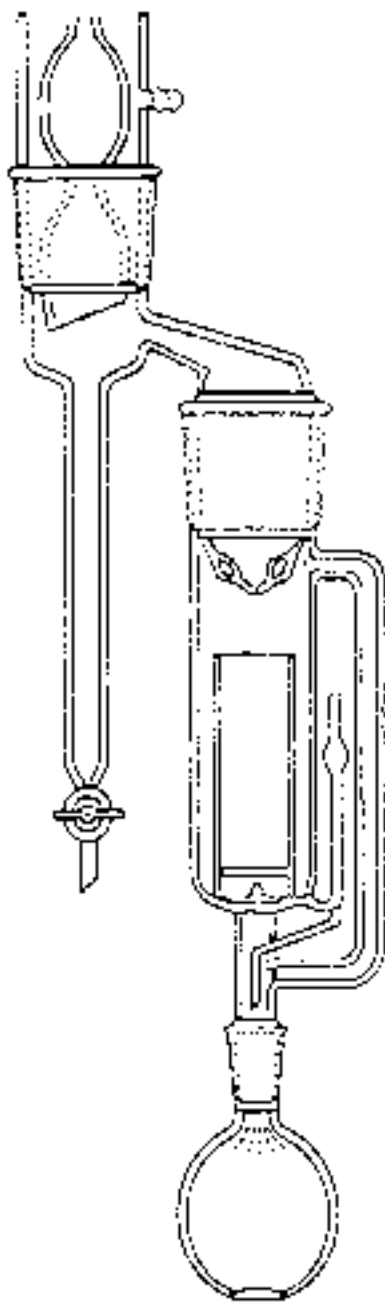

Figure 4 Solid-phase Extraction Apparatus



23 697-G

Figure 5 Soxhlet/Dean-Stark Extractor

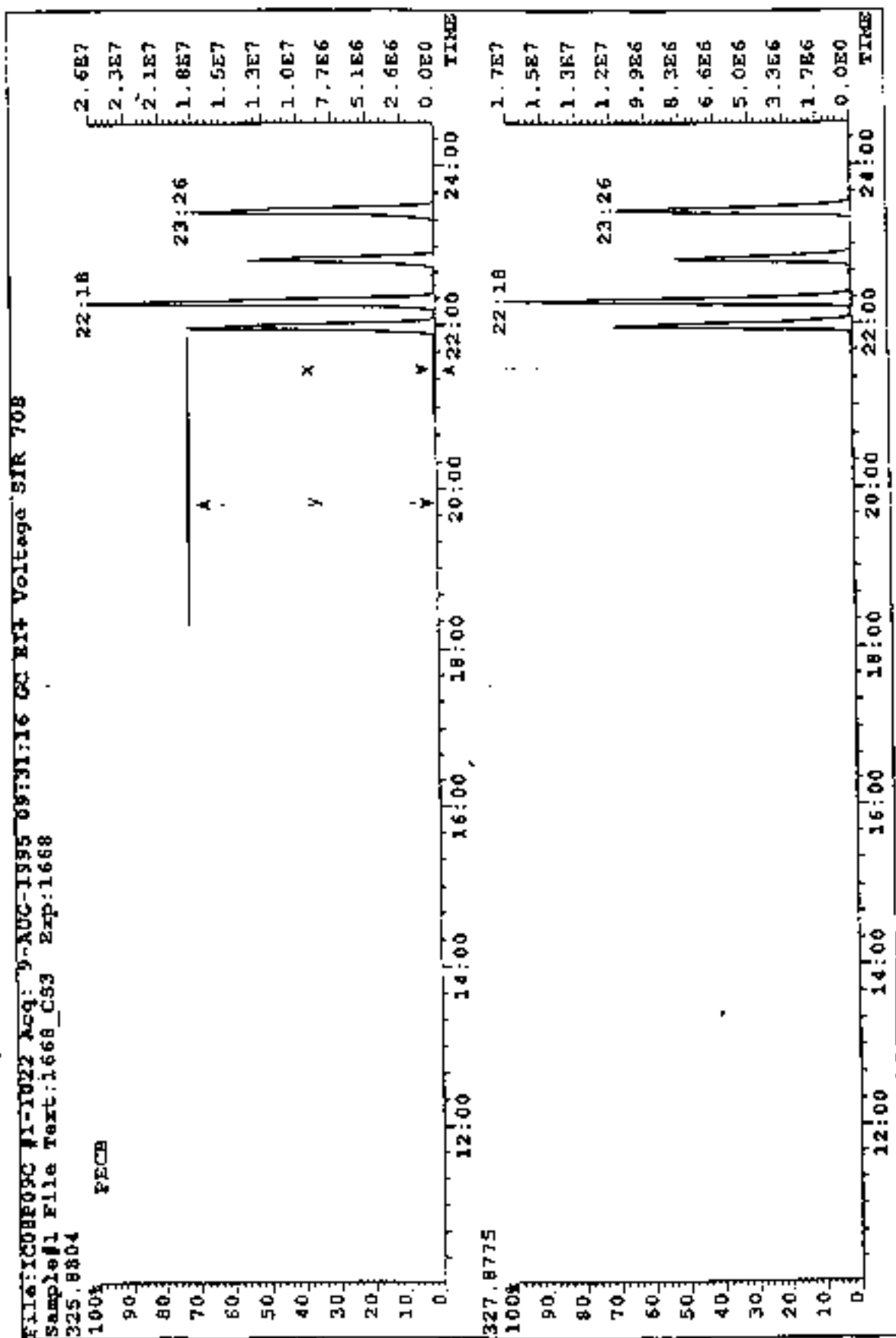

Figure 6 Congener-Specific Separation of Resolution Test Compounds on SPB-Octyl Column

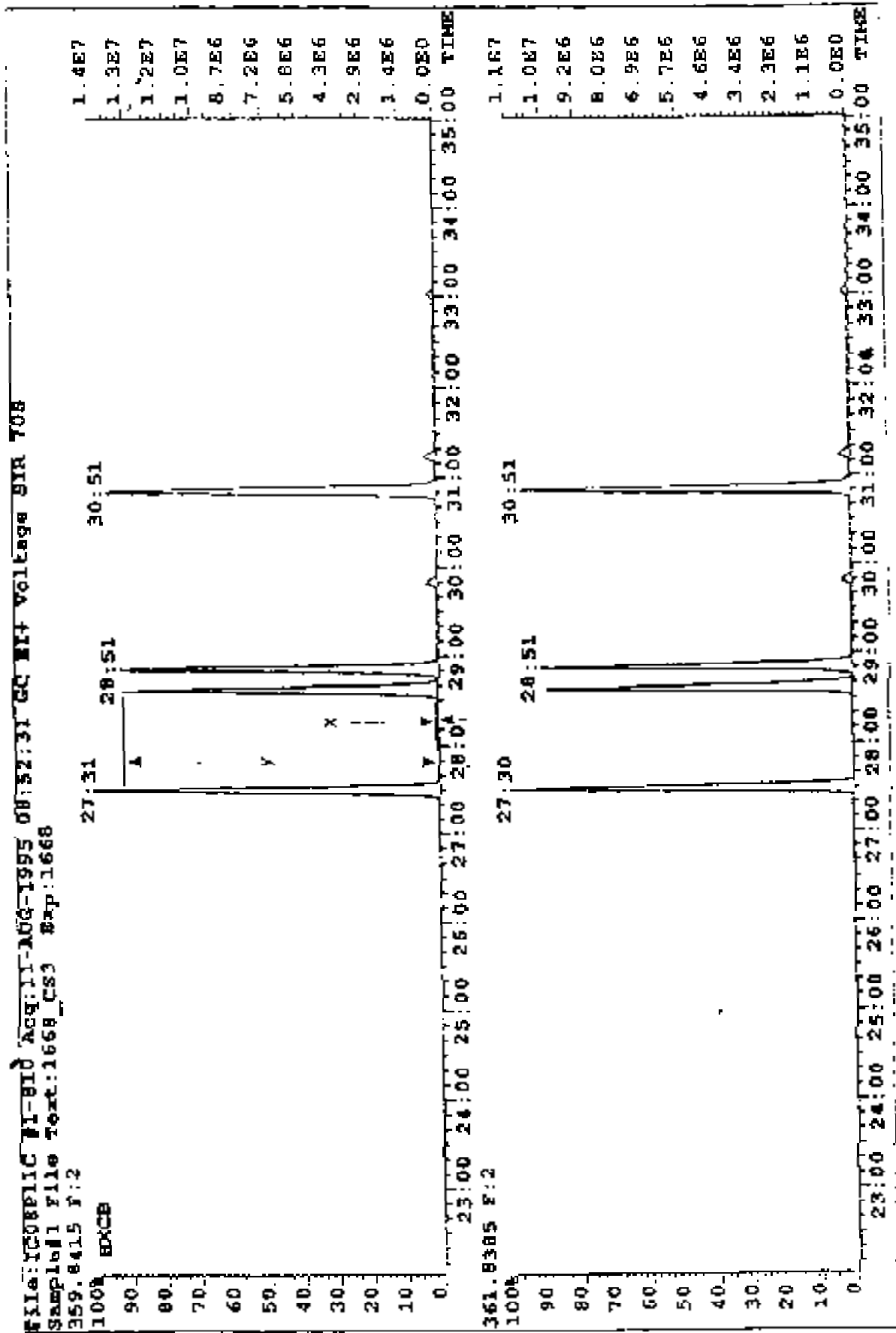

Figure 7 Congener-Specific Separation of PCBs 156 and 157 on DB-1 Column

24.0 Glossary of Definitions and Purposes

These definitions and purposes are specific to this method but have been conformed to common usage as much as possible.

24.1 Units of weight and measure and their abbreviations

24.1.1 Symbols

°C	degrees Celsius
µL	microliter
µm	micrometer
<	less than
>	greater than
%	percent

24.1.2 Alphabetical abbreviations

amp	ampere
cm	centimeter
g	gram
h	hour
ID	inside diameter
in.	inch
L	liter
M	Molecular ion
m	meter
mg	milligram
min	minute
mL	milliliter
mm	millimeter
m/z	mass-to-charge ratio
N	normal; gram molecular weight of solute divided by hydrogen equivalent of solute, per liter solution
OD	outside diameter
pg	picogram
ppb	part-per-billion
ppm	part-per-million
ppq	part-per-quadrillion
ppt	part-per-trillion
psig	pounds-per-square inch gauge
v/v	volume per unit volume
w/v	weight per unit volume

24.2 Definitions and acronyms (in alphabetical order).

Analyte: A PCB tested for by this method. The analytes are listed in Table 1.

Calibration standard (CAL): A solution prepared from a secondary standard and/or stock solutions used to calibrate the response of the instrument with respect to analyte concentration.

Calibration verification standard (VER): The mid-point calibration standard (CS3) that is used in to verify calibration. See Table 4.

CS1, CS2, CS3, CS4, CS5: See Calibration standards and Table 4.

DCB: Decachlorobiphenyl (PCB 209)

Field blank: An aliquot of reagent water or other reference matrix that is placed in a sample container in the laboratory or the field, and treated as a sample in all respects, including exposure to sampling site conditions, storage, preservation, and all analytical procedures. The purpose of the field blank is to determine if the field or sample transporting procedures and environments have contaminated the sample.

GC: Gas chromatograph or gas chromatography.

GPC: Gel permeation chromatograph or gel permeation chromatography.

HpCB: Heptachlorobiphenyl

HPLC: High performance liquid chromatograph or high performance liquid chromatography.

HRGC: High resolution GC.

HRMS: High resolution MS.

HxCB: Hexachlorobiphenyl

IPR: Initial precision and recovery; four aliquots of the diluted PAR standard analyzed to establish ability to generate acceptable precision and accuracy. An IPR is performed prior to the first time the method is used and any time the method or instrumentation is modified.

K-D: Kuderna-Danish concentrator; a device used to concentrate the analytes in a solvent.

Laboratory blank: See Method blank.

Laboratory control sample (LCS): See Ongoing precision and recovery standard (OPR).

Laboratory reagent blank: See Method blank.

May: This action, activity, or procedural step is neither required nor prohibited.

May not: This action, activity, or procedural step is prohibited.

Method blank: An aliquot of reagent water that is treated exactly as a sample including exposure to glassware, equipment, solvents, reagents, internal standards, and surrogates that are used with samples. The method blank is used to determine if analytes or interferences are present in the laboratory environment, the reagents, or the apparatus.

Minimum level (ML): The level at which the entire analytical system must give a recognizable signal and acceptable calibration point for the analyte. It is equivalent to the concentration of the lowest calibration standard, assuming that all method-specified sample weights, volumes, and cleanup procedures have been employed.

MS: Mass spectrometer or mass spectrometry.

Must: This action, activity, or procedural step is required.

OPR: Ongoing precision and recovery standard (OPR); a laboratory blank spiked with known quantities of analytes. The OPR is analyzed exactly like a sample. Its purpose is to assure that the results produced by the laboratory remain within the limits specified in this method for precision and recovery.

PAR: Precision and recovery standard; secondary standard that is diluted and spiked to form the I and OPR.

PFK: Perfluorokerosene; the mixture of compounds used to calibrate the exact m/z scale in the HRMS.

Preparation blank: See Method blank.

Primary dilution standard: A solution containing the specified analytes that is purchased or prepared from stock solutions and diluted as needed to prepare calibration solutions and other solutions.

Quality control check sample (QCS): A sample containing all or a subset of the analytes at known concentrations. The QCS is obtained from a source external to the laboratory or is prepared from source of standards different from the source of calibration standards. It is used to check laboratory performance with test materials prepared external to the normal preparation process.

PeCB: Pentachlorobiphenyl

PCB: Polychlorinated biphenyl

Reagent water: water demonstrated to be free from the analytes of interest and potentially interfering substances at the method detection limit for the analyte.

Relative standard deviation (RSD): The standard deviation times 100 divided by the mean. Also termed "coefficient of variation."

RF: Response factor. See Section 10.6.1.

RR: Relative response. See Section 10.5.2.

RSD: See Relative standard deviation.

SDS: Soxhlet/Dean-Stark extractor; an extraction device applied to the extraction of solid and semi-solid materials (Reference 12 and Figure 5).

Should: This action, activity, or procedural step is suggested but not required.

SICP: Selected ion current profile; the line described by the signal at an exact m/z.

SPE: Solid-phase extraction; an extraction technique in which an analyte is extracted from an aqueous sample by passage over or through a material capable of reversibly adsorbing the analyte. Also termed liquid-solid extraction.

Specificity: The ability to measure an analyte of interest in the presence of interferences and other analytes of interest encountered in a sample.

Stock solution: A solution containing an analyte that is prepared using a reference material traceable to EPA, the National Institute of Science and Technology (NIST), or a source that will attest to the purity and authenticity of the reference material.

TCB: Tetrachlorobiphenyl.

VER: See Calibration verification standard.