



Method 1614
Brominated Diphenyl Ethers in Water Soil,
Sediment and Tissue by HRGC/HRMS

August 2007

U.S. Environmental Protection Agency
Office of Water
Office of Science and Technology
Engineering and Analysis Division (4303T)
1200 Pennsylvania Avenue, NW
Washington, DC 20460

EPA-821-R-07-005

Method 1614

Brominated Diphenyl Ethers in Water, Soil, Sediment, and Tissue by HRGC/HRMS

August 2007

Introduction

EPA Method 1614 was developed by the Office of Water's Office of Science and Technology (OST) to determine polybrominated diphenyl ether (PBDE) congeners in aqueous, solid, tissue, and multi-phase matrices. These ethers are used in brominated flame retardants. The method uses isotope dilution and internal standard high resolution gas chromatography/high resolution mass spectrometry (HRGC/HRMS).

This version revises the August 2003 version to include use of a temperature programmed injector/vaporizer and a short column to improve recoveries of the octa-, nona- and decabrominated diphenyl ethers.

Acknowledgments

EPA Method 1614 was developed under EPA contract by DynCorp Environmental and Interface, Inc. Data were provided by Axys Analytical Services, Ltd., Sidney, BC, Canada.

Disclaimer

This PBDE-congener method is patterned after the EPA PCB-congener Method 1668A. The method specifications are based on data from Axys Analytical. Method 1614 has been reviewed by the Engineering and Analytical Support Branch in the Engineering and Analysis Division (EAD) of OST. The method is available for general use, but has not been published in 40 CFR Part 136. Mention of trade names or commercial products does not constitute endorsement or recommendation for use.

Please address your questions or comments to:

CWA Methods Team
Engineering and Analytical Support Branch/EAD (4303T)
Office of Science and Technology
U.S. Environmental Protection Agency
1200 Pennsylvania Avenue
Washington, DC 20460

E-mail: OSTCWAMethods@epa.gov

Method 1614

Brominated Diphenyl Ether Congeners in Water, Soil, Sediment, Biosolids and Tissue by HRGC/HRMS

August 2007

1.0 Scope and application

- 1.1** EPA Method 1614 ("Method 1614"; the "Method") is for determination of brominated diphenyl ether (BDE) congeners in water, soil, sediment, biosolids, tissue, and other sample matrices by high resolution gas chromatography combined with high resolution mass spectrometry (HRGC/HRMS).
- 1.1.1** The 209 BDE congeners are listed in Table 1. The 8 congeners of primary interest ("BDEs of primary interest"; Reference 1) are shown in **boldface** type. Congeners that have been reported as being found in environmental samples (References 2 and 3) are shown in *italics*. Congeners that allow determination of BDEs at those levels of bromination not found in environmental samples (References 2 and 3) are shown by footnote in Table 1. Other congeners in Table 1 may be determined as standards become available and as needs arise. Data are provided in Tables 2 - 6 for congeners that have been tested.
- 1.1.2** This Method can also be used to test for other brominated flame retardants (BFR) and brominated organic compounds in the event that new products come on the market.
- 1.2** This method is based on EPA Method 1668A (Reference 4) and a method developed by a commercial testing laboratory (Reference 5).
- 1.3** The detection and quantitation limits in this Method are usually dependent on the level of interferences and laboratory backgrounds rather than instrumental limitations. The method detection limits and (MDLs) and minimum levels of quantitation (MLs) in Table 2 are the levels at which the BDEs can be determined with laboratory contamination present. The estimated MDL for BDE 99 in water is 5 pg/L (picograms-per-liter (pg/L); parts-per-quadrillion (ppq)) with no interferences present.
- 1.4** The GC/MS portions of this Method are for use only by analysts experienced with HRGC/HRMS or under the close supervision of such qualified persons. Each laboratory that uses this Method must demonstrate the ability to generate acceptable results using the procedure in Section 9.2.
- 1.5** This method is performance-based. The laboratory is permitted to omit any step or modify any procedure (e.g., to overcome interferences or lower the cost of measurements), provided that all performance requirements in this method are met. Requirements for establishing equivalency are given in Section 9.1.2, and additionally for Clean Water Act (CWA) uses, at 40 CFR 136.6. For use in regulatory programs, such as the CWA, any modification beyond the modifications expressly permitted in this method, or at 40 CFR 136.6 is a modification that may require prior review and approval.

2.0 Summary of Method

Flow charts that summarize procedures for sample preparation, extraction, and analysis are given in Figure 1 for aqueous and solid samples, Figure 2 for multi-phase samples, and Figure 3 for tissue samples.

2.1 Extraction, concentration, and cleanup

2.1.1 Aqueous samples (samples containing less than one percent solids)—Stable isotopically labeled analogs of the BDEs are spiked into a 1-L sample. The sample is extracted using solid-phase extraction (SPE), separatory funnel extraction (SFE), or continuous liquid/liquid extraction (CLLE).

2.1.2 Solid, semi-solid, and multi-phase samples (excluding tissue)—The labeled compounds are spiked into a sample containing 10 g (dry weight) of solids. Samples containing multiple phases are pressure filtered and any aqueous liquid is discarded. Coarse solids are ground or homogenized. Any non-aqueous liquid from multi-phase samples is combined with the solids and extracted in a Soxhlet/Dean-Stark extractor.

2.1.3 Fish and other tissue—A 20-g aliquot of sample is homogenized, and a 10-g aliquot is spiked with the labeled compounds. The sample is mixed with anhydrous sodium sulfate, dried for a minimum of 30 minutes, and extracted for 18-24 hours using methylene chloride in a Soxhlet extractor. The extract is evaporated to dryness, and the lipid content is determined.

2.2 After extraction, a labeled cleanup standard is spiked into the extract and the extract is concentrated. Tissue extracts are first cleaned up using an anthropogenic isolation column, and all extracts are cleaned up using back-extraction with sulfuric acid and/or base, and gel permeation, silica gel, and/or Florisil or alumina chromatography, as required.

2.3 After cleanup, the extract is concentrated to 20 μ L and labeled injection internal standards are added. An aliquot of the extract is injected into the gas chromatograph (GC). The analytes are separated by the GC and detected by a high-resolution ($\geq 5,000$) mass spectrometer. Two exact m/zs are monitored at each level of bromination (LOB) throughout a pre-determined retention time window.

2.4 An individual BDE congener is identified by comparing the GC retention time and ion-abundance ratio of two exact m/zs with the corresponding retention time of an authentic standard and the theoretical or acquired ion-abundance ratio of the two exact m/zs.

2.5 Quantitative analysis is performed in one of two ways using selected ion current profile (SICP) areas:

2.5.1 For a BDE of primary interest and for other congeners of interest for which a labeled analog is available, the GC/MS is multi-point calibrated and the concentration is determined using the isotope dilution technique.

2.5.2 For a BDE of primary interest for which a labeled analog is not available and for a congener of interest for which a multi-point calibration is desired, the GC/MS is multi-point calibrated and the concentration is determined using the internal standard technique.

2.5.3 For other congeners for which a multi-point calibration is not necessary, the GC/MS is calibrated at a single concentration and the concentration is determined using the internal standard technique.

2.5.4 For the labeled analogs of the BDEs quantitated by isotope dilution (Section 2.5.1) and for the cleanup standards, the GC/MS is calibrated at a single concentration and the concentrations of these labeled compounds in samples are determined using the internal standard technique.

2.6 The quality of the analysis is assured through reproducible calibration and testing of the extraction, cleanup, and HRGC/HRMS systems.

3.0 Definitions

Definitions are given in the glossary at the end of this Method.

4.0 Contamination and interferences

4.1 Solvents, reagents, glassware, and other sample processing hardware may yield artifacts, elevated baselines, and/or lock-mass suppression causing misinterpretation of chromatograms. Specific selection of reagents and purification of solvents by distillation in all-glass systems may be required. Where possible, reagents are cleaned by extraction or solvent rinse. Environmentally abundant BDEs have shown to be difficult to completely eliminate from the laboratory at levels lower than the MDLs in this Method (Table 2).

4.2 Proper cleaning of glassware is extremely important, because glassware may not only contaminate the samples but may also remove the analytes of interest by adsorption on the glass surface.

4.2.1 Glassware should be rinsed with solvent and washed with a detergent solution as soon after use as is practical. Sonication of glassware containing a detergent solution for approximately 30 seconds may aid in cleaning. Glassware with removable parts, particularly separatory funnels with fluoropolymer stopcocks, must be disassembled prior to detergent washing.

4.2.2 After detergent washing, glassware should be rinsed immediately, first with methanol, then with hot tap water. The tap water rinse is followed by another methanol rinse, then acetone, and then methylene chloride.

4.2.3 Baking of glassware in a kiln or other high temperature furnace (300 - 500 °C) may be warranted after particularly dirty samples are encountered. The kiln or furnace should be vented to prevent laboratory contamination by BDE vapors. Baking should be minimized, as repeated baking of glassware may cause active sites on the glass surface that may irreversibly adsorb BDEs.

4.2.4 Immediately prior to use, the Soxhlet apparatus should be pre-extracted for approximately 3 hours with the solvent to be used for the extraction (see Sections 12.3.1-12.3.3). Other extraction apparatus (Section 6.4) should also be rinsed prior to use.

- 4.2.5** A separate set of glassware may be necessary to effectively preclude contamination when low-level samples are analyzed.
- 4.3** All materials used in the analysis must be demonstrated to be free from interferences by running reference matrix method blanks (Section 9.5) initially and with each sample batch (samples started through the extraction process on a given 12-hour shift, to a maximum of 20 samples).
- 4.3.1** The reference matrix must simulate, as closely as possible, the sample matrix under test. Ideally, the reference matrix should not contain the BDEs in detectable amounts, but should contain potential interferants in the concentrations expected to be found in the samples to be analyzed.
- 4.3.2** When a reference matrix that simulates the sample matrix under test is not available, reagent water (Section 7.6.1) can be used to simulate water; playground sand (Section 7.6.2) or white quartz sand (Section 7.3.2) can be used to simulate soil; filter paper (Section 7.6.3) can be used to simulate paper and similar materials; and corn oil (Section 7.6.4) can be used to simulate tissue.
- 4.4** Interferences co-extracted from samples will vary considerably from source to source, depending on the diversity of the site being sampled. Interfering compounds may be present at concentrations several orders of magnitude higher than the BDEs. Because low levels of BDEs are measured by this Method, the elimination of interferences is essential. The cleanup steps given in Section 13 can be used to reduce or eliminate these interferences and thereby permit reliable determination of the BDEs at the levels shown in Table 2.
- 4.5** Each piece of reusable glassware should be numbered to associate that glassware with the processing of a particular sample. This will assist the laboratory in tracking possible sources of contamination for individual samples, identifying glassware associated with highly contaminated samples that may require extra cleaning, and determining when glassware should be discarded.
- 4.6** Contamination of calibration solutions—The MDLs and MLs in Table 2 are the levels that can be achieved with normal laboratory backgrounds present. Many of the MLs are greater than the equivalent concentrations of the calibration solutions. In order to prevent contamination of the calibration solutions with the backgrounds allowed by the MLs, the calibration solutions must be prepared in an area free from BDE contamination using glassware free from contamination. If these requirements cannot be met or are difficult to meet in the laboratory, the laboratory should prepare the calibration solutions in a contamination-free facility or have a vendor prepare the calibration standards and guarantee freedom from contamination.
- 4.7** Cleanup of tissue—The natural lipid content of tissue can interfere in the analysis of tissue samples for the BDEs. The lipid contents of different species and portions of tissue can vary widely. Lipids are soluble to varying degrees in various organic solvents and may be present in sufficient quantity to overwhelm the column chromatographic cleanup procedures used for cleanup of sample extracts. Lipids must be removed by the anthropogenic isolation column procedure in Section 13.5, followed by the gel permeation chromatography procedure in Section 13.2. Florisil (Section 13.6) and/or alumina (Section 13.4) are recommended as additional cleanup steps.

5.0 Safety

5.1 The toxicity or carcinogenicity of each chemical used in this Method has not been precisely determined; however, each compound should be treated as a potential health hazard. Exposure to these compounds should be reduced to the lowest possible level.

5.1.1 BDEs are under investigation as suspected human or mammalian carcinogens. On the basis of the available toxicological and physical properties of the BDEs, pure standards should be handled only by highly trained personnel thoroughly familiar with handling and cautionary procedures and the associated risks.

5.1.2 It is recommended that the laboratory purchase dilute standard solutions of the analytes in this Method. However, if primary solutions are prepared, they must be prepared in a hood, and a NIOSH/MESA approved toxic gas respirator must be worn when high concentrations are handled.

5.2 The laboratory is responsible for maintaining a current awareness file of OSHA regulations regarding the safe handling of the chemicals specified in this Method. A reference file of material safety data sheets (MSDSs) should also be made available to all personnel involved in these analyses. The laboratory should perform personal hygiene monitoring of each analyst who uses this Method and the results of this monitoring be made available to the analyst. Additional information on laboratory safety can be found in References 6-9. The references and bibliography at the end of Reference 8 are particularly comprehensive in dealing with the general subject of laboratory safety.

5.3 The pure BDEs and samples suspected to contain these compounds are handled using essentially the same techniques employed in handling radioactive or infectious materials. Well-ventilated, controlled access laboratories are required. Assistance in evaluating the health hazards of particular laboratory conditions may be obtained from certain consulting laboratories and from State Departments of Health or Labor, many of which have an industrial health service. Each laboratory must develop a strict safety program for handling these compounds. The practices in EPA Method 613 (40 CFR 136, Appendix A, Section 4.1) for handling chlorinated dibenzo-*p*-dioxins and dibenzofurans (CDDs/CDFs) are also recommended for handling the BDEs.

5.3.1 Facility—When finely divided samples (dusts, soils, dry chemicals) are handled, all operations (including removal of samples from sample containers, weighing, transferring, and mixing) should be performed in a glove box demonstrated to be leak tight or in a fume hood demonstrated to have adequate air flow. Gross losses to the laboratory ventilation system must not be allowed. Handling of the dilute solutions normally used in analytical and animal work presents no inhalation hazards except in the case of an accident.

5.3.2 Protective equipment—Disposable plastic gloves, apron or lab coat, safety glasses or mask, and a glove box or fume hood adequate for radioactive work should be used. During analytical operations that may give rise to aerosols or dusts, personnel should wear respirators equipped with activated carbon filters. Eye protection (preferably full face shields) must be worn while working with exposed samples or pure analytical standards. Latex gloves are commonly used to reduce exposure of the hands. When handling samples suspected or known to contain high concentrations of the BDEs, an additional set of gloves can also be worn beneath the latex gloves.

- 5.3.3** Training—Workers must be trained in the proper method of removing contaminated gloves and clothing without contacting the exterior surfaces.
- 5.3.4** Personal hygiene—Hands and forearms should be washed thoroughly after each manipulation and before breaks (coffee, lunch, and shift).
- 5.3.5** Confinement—Isolated work areas posted with signs, segregated glassware and tools, and plastic absorbent paper on bench tops will aid in confining contamination.
- 5.3.6** Effluent vapors—The effluent of the sample splitter from the gas chromatograph (GC) and from roughing pumps on the mass spectrometer (MS) should pass through either a column of activated charcoal or be bubbled through a trap containing oil or high-boiling alcohols to condense BDE vapors.
- 5.3.7** Waste Handling—Good technique includes minimizing contaminated waste. Plastic bag liners should be used in waste cans. Janitors and other personnel should be trained in the safe handling of waste.
- 5.3.8** Decontamination
- 5.3.8.1** Decontamination of personnel—Use any mild soap with plenty of scrubbing action.
- 5.3.8.2** Glassware, tools, and surfaces—An ethanol solution is a less toxic solvent that should be effective in removing BDEs. Satisfactory cleaning may be accomplished by rinsing with ethanol, then washing with detergent and water. If glassware is first rinsed with solvent, the wash water may be disposed of in the sewer. Given the cost of disposal, it is prudent to minimize solvent wastes.
- 5.3.9** Laundry—Clothing known to be contaminated should be collected in plastic bags. Persons that convey the bags and launder the clothing should be advised of the hazard and trained in proper handling. The clothing may be put into a washing machine without contact if the launderer knows of the potential problem. The machine should be run through a cycle before being used again for other clothing.
- 5.3.10** Wipe tests—A useful method of determining cleanliness of work surfaces and tools is to perform a wipe test of the surface suspected of being contaminated.
- 5.3.10.1** Using a piece of filter paper moistened with ethanol or other solvent, wipe an area approximately 10 x 10 cm.
- 5.3.10.2** Extract and analyze the wipe by GC with an electron capture detector (ECD) or by this Method.
- 5.3.10.3** Using the area wiped (e.g., 10 x 10 cm = 0.01 m²), calculate the concentration in µg/m². A concentration less than 1 µg/m² indicates acceptable cleanliness; anything higher warrants further cleaning. More than 100 µg/m² constitutes an acute hazard and requires prompt cleaning before further use of the equipment or work space, and indicates that unacceptable work practices have been employed.

6.0 Apparatus and materials

Note: Brand names, suppliers, and part numbers are for illustration purposes only and no endorsement is implied. Equivalent performance may be achieved using apparatus and materials other than those specified here. Meeting the performance requirements of this Method is the responsibility of the laboratory.

6.1 Sampling equipment for discrete or composite sampling

6.1.1 Sample bottles and caps

6.1.1.1 Liquid samples (waters, sludges and similar materials containing 5 percent solids or less)—Sample bottle, amber glass, 1.1-L minimum, with screw cap.

6.1.1.2 Solid samples (soils, sediments, sludges, paper pulps, filter cake, compost, and similar materials that contain more than 5 percent solids)—Sample bottle, wide-mouth, amber glass, 100-mL minimum.

6.1.1.3 If amber bottles are not available, samples must be protected from light.

6.1.1.4 Bottle caps—Threaded to fit sample bottles. Caps must be lined with fluoropolymer.

6.1.1.5 Cleaning

6.1.1.5.1 Bottles are detergent water washed, then solvent rinsed before use.

6.1.1.5.2 Liners are detergent water washed and rinsed with reagent water (Section 7.6.1).

6.1.2 Compositing equipment—Automatic or manual compositing system incorporating glass containers cleaned per the bottle cleaning procedure above. Only glass or fluoropolymer tubing must be used. If the sampler uses a peristaltic pump, a minimum length of compressible silicone rubber tubing may be used in the pump only. Before use, the tubing must be thoroughly rinsed with methanol, followed by repeated rinsing with reagent water to minimize sample contamination. An integrating flow meter is used to collect proportional composite samples.

6.2 Equipment for glassware cleaning

Note: If blanks from bottles or other glassware or with fewer cleaning steps than required above show no detectable BDE contamination, unnecessary cleaning steps and equipment may be eliminated.

6.2.1 Laboratory sink with overhead fume hood

6.2.2 Kiln—Capable of reaching 450 °C within 2 hours and maintaining 450 - 500 °C within \pm 10 °C, with temperature controller and safety switch (Cress Manufacturing Co, Santa Fe Springs, CA, B31H, X31TS, or equivalent). See the precautions in Section 4.2.3.

6.3 Equipment for sample preparation

- 6.3.1 Laboratory fume hood of sufficient size to contain the sample preparation equipment listed below.
- 6.3.2 Glove box (optional)
- 6.3.3 Tissue homogenizer—VirTis Model 45 Macro homogenizer (American Scientific Products H-3515, or equivalent) with stainless steel Macro-shaft and Turbo-shear blade.
- 6.3.4 Meat grinder—Hobart, or equivalent, with 3- to 5-mm holes in inner plate.
- 6.3.5 Equipment for determining percent moisture
 - 6.3.5.1 Oven—Capable of maintaining a temperature of 110 ± 5 °C
 - 6.3.5.2 Desiccator
- 6.3.6 Balances
 - 6.3.6.1 Analytical—Capable of weighing 0.1 mg
 - 6.3.6.2 Top loading—Capable of weighing 10 mg

6.4 Extraction apparatus

- 6.4.1 Water samples
 - 6.4.1.1 pH meter, with combination glass electrode
 - 6.4.1.2 pH paper, wide range (Hydriion Papers, or equivalent)
 - 6.4.1.3 Graduated cylinder, 1-L capacity
 - 6.4.1.4 Liquid/liquid extraction—Separatory funnels, 250-, 500-, and 2000-mL, with fluoropolymer stopcocks
 - 6.4.1.5 Solid-phase extraction
 - 6.4.1.5.1 Filtration apparatus, 1-L, including glass funnel, frit support, clamp, adapter, stopper, filtration flask, and vacuum tubing (Figure 4). For wastewater samples, the apparatus should accept 90 or 144 mm disks. For drinking water or other samples containing low solids, smaller disks may be used.
 - 6.4.1.5.2 Vacuum source—Capable of maintaining 25 in. Hg, equipped with shutoff valve and vacuum gauge
 - 6.4.1.5.3 Glass-fiber filter—Whatman GMF 150 (or equivalent), 1 micron pore size, to fit filtration apparatus in Section 6.4.1.5.1

- 6.4.1.5.4** Solid-phase extraction disk containing octadecyl (C₁₈) bonded silica uniformly enmeshed in an inert matrix—Fisher Scientific 14-378F (or equivalent), to fit filtration apparatus in Section 6.4.1.5.1
- 6.4.1.6** Continuous liquid/liquid extraction (CLLE)—Fluoropolymer or glass connecting joints and stopcocks without lubrication, 1.5-2 L capacity (Hershberg-Wolf Extractor, Cal-Glass, Costa Mesa, California, or equivalent).
- 6.4.2** Soxhlet/Dean-Stark (SDS) extractor (Figure 5 and Reference 10) for filters and solid/sludge samples
 - 6.4.2.1** Soxhlet—50-mm ID, 200-mL capacity with 500-mL flask (Cal-Glass LG-6900, or equivalent, except substitute 500-mL round-bottom flask for 300-mL flat-bottom flask)
 - 6.4.2.2** Thimble—43 × 123 to fit Soxhlet (Cal-Glass LG-6901-122, or equivalent)
 - 6.4.2.3** Moisture trap—Dean-Stark or Barrett with fluoropolymer stopcock, to fit Soxhlet
 - 6.4.2.4** Heating mantle—Hemispherical, to fit 500-mL round-bottom flask (Cal-Glass LG-8801-112, or equivalent)
 - 6.4.2.5** Variable transformer—Powerstat (or equivalent), 110-volt, 10-amp
- 6.4.3** Beakers—400- to 500-mL
- 6.4.4** Spatulas—Stainless steel
- 6.5** Filtration apparatus
 - 6.5.1** Pyrex glass wool—Solvent-extracted using a Soxhlet or SDS extractor for 3 hours minimum
 - 6.5.2** Glass funnel—125- to 250-mL
 - 6.5.3** Glass-fiber filter paper—Whatman GF/D (or equivalent), to fit glass funnel in Section 6.5.2.
 - 6.5.4** Drying column—15- to 20-mm ID Pyrex chromatographic column equipped with coarse-glass frit or glass-wool plug
 - 6.5.5** Buchner funnel—15-cm
 - 6.5.6** Glass-fiber filter paper for Buchner funnel above
 - 6.5.7** Filtration flasks—1.5- to 2.0-L, with side arm
 - 6.5.8** Pressure filtration apparatus—Millipore YT30 142 HW, or equivalent

6.6 Centrifuge apparatus

- 6.6.1 Centrifuge—Capable of rotating 500-mL centrifuge bottles or 15-mL centrifuge tubes at 5,000 rpm minimum
- 6.6.2 Centrifuge bottles—500-mL, with screw-caps, to fit centrifuge
- 6.6.3 Centrifuge tubes—12- to 15-mL, with screw-caps, to fit centrifuge

6.7 Cleanup apparatus

- 6.7.1 Automated gel permeation chromatograph (Analytical Biochemical Labs, Inc, Columbia, MO, Model GPC Autoprep 1002, or equivalent)
 - 6.7.1.1 Column—600-700 mm long \times 25 mm ID glass, packed with 70 g of 200-400 mesh SX-3 Bio-beads (Bio-Rad Laboratories, Richmond, CA, or equivalent)
 - 6.7.1.2 Syringe—10-mL, with Luer fitting
 - 6.7.1.3 Syringe filter holder—stainless steel, and glass-fiber or fluoropolymer filters (Gelman 4310, or equivalent)
 - 6.7.1.4 UV detectors—254-nm, preparative or semi-preparative flow cell (Isco, Inc., Type 6; Schmadzu, 5-mm path length; Beckman-Altex 152W, 8- μ L micro-prep flow cell, 2-mm path; Pharmacia UV-1, 3-mm flow cell; LDC Milton-Roy UV-3, monitor #1203; or equivalent)
- 6.7.2 Pipets
 - 6.7.2.1 Disposable, Pasteur, 150-mm long \times 5-mm ID (Fisher Scientific 13-678-6A, or equivalent)
 - 6.7.2.2 Disposable, serological, 50-mL (8- to 10- mm ID)
- 6.7.3 Glass chromatographic columns
 - 6.7.3.1 150-mm long \times 8-mm ID, (Kontes K-420155, or equivalent) with coarse-glass frit or glass-wool plug and 250-mL reservoir
 - 6.7.3.2 200-mm long \times 15-mm ID, with coarse-glass frit or glass-wool plug and 250-mL reservoir
 - 6.7.3.3 300-mm long \times 22-mm ID, with coarse-glass frit, 300-mL reservoir, and glass or fluoropolymer stopcock
- 6.7.4 Oven—For baking and storage of absorbents, capable of maintaining a constant temperature (± 5 °C) in the range of 105-250 °C

6.8 Concentration apparatus

6.8.1 Rotary evaporator—Buchi/Brinkman-American Scientific No. E5045-10 or equivalent, equipped with a variable temperature water bath

6.8.1.1 Vacuum source for rotary evaporator equipped with shutoff valve at the evaporator and vacuum gauge

6.8.1.2 A recirculating water pump and chiller are recommended, as use of tap water for cooling the evaporator wastes large volumes of water and can lead to inconsistent performance as water temperatures and pressures vary.

6.8.1.3 Round-bottom flask—100-mL and 500-mL or larger, with ground-glass fitting compatible with the rotary evaporator

6.8.2 Kuderna-Danish (K-D) concentrator

6.8.2.1 Concentrator tube—10-mL, graduated (Kontes K-570050-1025, or equivalent) with calibration verified. Ground-glass stopper (size 19/22 joint) is used to prevent evaporation of extracts.

6.8.2.2 Evaporation flask—500-mL (Kontes K-570001-0500, or equivalent), attached to concentrator tube with springs (Kontes K-662750-0012 or equivalent)

6.8.2.3 Snyder column—Three-ball macro (Kontes K-503000-0232, or equivalent)

6.8.2.4 Boiling chips

6.8.2.4.1 Glass or silicon carbide—Approximately 10/40 mesh, extracted with methylene chloride and baked at 450 °C for one hour minimum

6.8.2.4.2 Fluoropolymer (optional)—Extracted with methylene chloride

6.8.2.5 Water bath—Heated, with concentric ring cover, capable of maintaining a temperature in the range of 70-100 °C within ± 2 °C, installed in a fume hood

6.8.3 Nitrogen evaporation apparatus—Equipped with water bath controlled in the range of 30-60 °C (N-Evap, Organomation Associates, Inc., South Berlin, MA, or equivalent), installed in a fume hood

6.8.4 Sample vials

6.8.4.1 Amber glass, 2- to 5-mL with fluoropolymer-lined screw-cap

6.8.4.2 Glass, 0.3-mL, conical, with fluoropolymer-lined screw or crimp cap

6.9 Gas chromatograph—Must have splitless or on-column injection port for capillary column, temperature program with isothermal hold, and must meet all of the performance specifications in Section 10.

6.9.1 GC column—A single- or two-column system may be used, as follows:

6.9.1.1 Single-column—30±5-m long × 0.25±0.02-mm ID; 0.1-µm film; 95% methyl, 4% phenyl, 1% vinyl silicone for high temperature use (J&W DB-5HT, or equivalent). The column must meet the following specifications:

- 6.9.1.1.1** The absolute and relative retention times must be approximately equal to those in Table 2.
- 6.9.1.1.2** If the additional congeners listed in Tables 2 and 4 are determined, the column must uniquely resolve congener 49 from 71. Unique resolution means a valley height less than 40 percent of the shorter of the two peaks that result when the diluted combined congener solution (Section 7.10.2.2) is analyzed (see Figure 6). If the BDEs of primary interest only are determined, there is no column resolution test because these congeners are adequately resolved on the DB-5HT column.
- 6.9.1.1.3** The tailing factor (see Figure 13 in EPA Method 625; 40 CFR 136, Appendix A) for congener 99L in the CS-3 standard must be less than 3.00.
- 6.9.1.1.4** The retention time for decabromodiphenyl ether (DeBDE) must be greater than 48 minutes.
- 6.9.1.1.5** The column must be replaced when any of the criteria in Sections 6.9.1.1.1 - 6.9.1.1.4 are not met.

6.9.1.2 Two-column system—If a two-column system is used, one column to elute the mono- through nona- BDEs and another column to elute the DeBDE separately, the two-column system must meet the following specifications:

- 6.9.1.2.1** The retention time for the latest-eluted BDE on the column that elutes the mono- through nona- BDEs must be greater than the retention time for this compound on the DB-5HT column, as shown in Table 2, and the retention time for DeBDE must be greater than 10 minutes on the column used for determination of DeBDE.
- 6.9.1.2.2** Congener 49 must be uniquely resolved from congener 71 per Section 6.9.1.1.2 on the column that elutes the mono- through nona- BDEs if congeners in addition to the BDEs of primary interest are determined (Section 6.9.1.1.2).
- 6.9.1.2.3** The tailing factor specification in Section 6.9.1.1.3 must be met for congener 99L on the column that elutes the mono- through nona- BDEs and for DeBDE on its column.
- 6.9.1.2.4** The respective column must be replaced when any of the criteria in Sections 6.9.1.2.1 - 6.9.1.2.3 are not met.

6.9.1.3 If a column or column system alternate to the column or two-column system above is used, specifications similar to those for the column or two-column system (Sections

6.9.1.1 - 6.9.1.2) must be developed and must be functionally equivalent to those specifications.

6.9.2 Gas chromatograph short column - Optionally to prevent breakdown of octa, nona and deca congeners and improve recovery - temperature-programmed injector TPI (splitless) or on-column injection port for capillary column, temperature program for injector and column, with isothermal hold, and must meet all of the performance specifications in Section 9 and 10.

6.9.2.1 GC column-15±1-m long × 0.25±0.02-mm ID; 0.1-µm film; 95% methyl, 4% phenyl, 1% vinyl silicone for high temperature use (J&W DB-5HT, or equivalent). The column must meet the specifications in sections 6.9.2-6.

6.9.2.2 The absolute and relative retention times must be approximately equal to those in Table 2.

6.9.2.3 The column must uniquely resolve congener 49 from 71. Unique resolution means a valley height less than 40 percent of the shorter of the two peaks that result when the diluted combined congener solution (Section 7.10.2.2) is analyzed (see Figure 6). If the BDEs of primary interest only are determined, there is no column resolution test because these congeners are adequately resolved on the DB-5HT column.

6.9.2.4 The tailing factor (see Figure 13 in EPA Method 625; 40 CFR 136, Appendix A) for congener 99L in the CS-3 standard must be less than 3.00.

6.9.2.5 The retention time for decabromodiphenyl ether (DeBDE) must be greater than 45 minutes.

6.9.2.6 The column must be replaced when any of the criteria in Sections 6.9.2.2 - 6.9.2.5 are not met.

6.10 Mass spectrometer—28- to 40-eV electron impact ionization, must be capable of selectively monitoring a minimum of 15 exact m/zs minimum in a single function at high resolution (≥5,000) during a period less than 1.5 seconds, and must meet all of the performance specifications in Section 10.

6.11 GC/MS interface—The mass spectrometer (MS) must be interfaced to the GC such that the end of the capillary column terminates within 1 cm of the ion source but does not intercept the electron or ion beams.

6.12 Data system—Capable of collecting, recording, storing, and processing MS data.

6.12.1 Data acquisition—The signal at each exact m/z must be collected repetitively throughout the monitoring period and stored on a mass storage device.

6.12.2 Response factors and multipoint calibrations—The data system must record and maintain lists of response factors (response ratios for isotope dilution) and multipoint calibrations. Computations of relative standard deviation (RSD) are used to test calibration linearity. Statistics on initial (Section 9.4) and ongoing (Section 15.5.4) performance should be computed and maintained, either on the instrument data system, or on a separate computer system.

7.0 Reagents and standards

7.1 pH adjustment and back-extraction

- 7.1.1 Potassium hydroxide—Dissolve 20 g reagent grade KOH in 100 mL reagent water.
- 7.1.2 Sulfuric acid—Reagent grade (specific gravity 1.84)
- 7.1.3 Hydrochloric acid—Reagent grade, 6N
- 7.1.4 Sodium chloride—Reagent grade, prepare at 5% (w/v) solution in reagent water

7.2 Solution drying and evaporation

- 7.2.1 Solution drying—Sodium sulfate, reagent grade, granular, anhydrous (Baker 3375, or equivalent), rinsed with methylene chloride (20 mL/g), baked at 400 °C for 1 hour minimum, cooled in a desiccator, and stored in a pre-cleaned glass bottle with screw-cap that prevents moisture from entering. If, after heating, the sodium sulfate develops a noticeable grayish cast (due to the presence of carbon in the crystal matrix), that batch of reagent is not suitable for use and should be discarded. Extraction with methylene chloride (as opposed to simple rinsing) and baking at a lower temperature may produce sodium sulfate that is suitable for use.
- 7.2.2 Tissue drying—Sodium sulfate, reagent grade, powdered, treated and stored as in Section 7.2.1
- 7.2.3 Prepurified nitrogen

7.3 Extraction

- 7.3.1 Solvents—Acetone, toluene, cyclohexane, hexane, methanol, methylene chloride, isooctane, and nonane; distilled in glass, pesticide quality, lot-certified to be free of interferences

Note: Some solvents; e.g., isooctane and nonane, may need to be re-distilled to eliminate BDE backgrounds.

- 7.3.2 White quartz sand, 60/70 mesh—For Soxhlet/Dean-Stark extraction (Aldrich Chemical, Cat. No. 27-437-9, or equivalent). Bake at 450 °C for 4 hour minimum.

- 7.4 GPC calibration solution—Prepare a solution containing 2.5 mg/mL corn oil, 0.05 mg/mL bis(2-ethylhexyl) phthalate (BEHP), 0.01 mg/mL methoxychlor, 0.002 mg/mL perylene, and 0.008 mg/mL sulfur, or at concentrations appropriate to the response of the detector.

Note: At the time of writing of this method the calibration solution and the dump and collect times for BDEs had not been optimized. Because DeBDE has a molecular weight much higher than BEHP and methoxychlor, it may be necessary to include DeBDE in the calibration solution.

7.5 Adsorbents for sample cleanup—Any of the adsorbents listed below may be used for sample cleanup. Regardless of the cleanup used, the same quantity and type of adsorbent and the same procedure must be used for cleanup of all standards and samples.

7.5.1 Silica gel

7.5.1.1 Activated silica gel—100-200 mesh, Supelco 1-3651 (or equivalent), 100-200 mesh, rinsed with methylene chloride, baked at 180 °C for a minimum of 1 hour, cooled in a desiccator, and stored in a precleaned glass bottle with screw-cap that prevents moisture from entering.

7.5.1.2 Acid silica gel (30% w/w)—Thoroughly mix 44 g of concentrated sulfuric acid (Section 7.1.2) with 100 g of activated silica gel (Section 7.5.1.1) in a clean container. Break up aggregates with a stirring rod until a uniform mixture is obtained. Store in a screw-capped bottle with fluoropolymer-lined cap.

7.5.1.3 Basic silica gel—Thoroughly mix 30 g of 1N sodium hydroxide with 100 g of activated silica gel (Section 7.5.1.1) in a clean container. Break up aggregates with a stirring rod until a uniform mixture is obtained. Store in a screw-capped bottle with fluoropolymer-lined cap.

7.5.1.4 Potassium silicate

7.5.1.4.1 Dissolve 56 g of high purity potassium hydroxide (Aldrich, or equivalent) in 300 mL of methanol in a 750- to 1000-mL flat-bottom flask.

7.5.1.4.2 Add 100 g of activated silica gel (Section 7.5.1.1) and a stirring bar, and stir on an explosion-proof hot plate at 60-70 °C for 1-2 hours.

7.5.1.4.3 Decant the liquid and rinse the potassium silicate twice with 100-mL portions of methanol, followed by a single rinse with 100 mL of methylene chloride.

7.5.1.4.4 Spread the potassium silicate on solvent-rinsed aluminum foil and dry for 2-4 hours in a hood. Observe the precaution in Section 4.8.

7.5.1.4.5 Activate overnight at 200-250 °C prior to use.

7.5.2 Alumina—Either one of two types of alumina, acid or basic, may be used in the cleanup of sample extracts, provided that the laboratory can meet the performance specifications for the recovery of labeled compounds in Section 9.3.

7.5.2.1 Acid alumina—Supelco 19996-6C (or equivalent). Activate by heating to 130 °C for a minimum of 12 hours.

7.5.2.2 Basic alumina—Supelco 19944-6C (or equivalent). Activate by heating to 600 °C for a minimum of 24 hours. Alternatively, activate by heating in a tube furnace at 650 to 700 °C under an air flow rate of approximately 400 cc/minute. Do not heat over 700 °C, as this can lead to reduced capacity for retaining the analytes. Store at 130 °C in a covered flask. Use within five days of baking.

7.5.3 Anthropogenic isolation column—Pack the column in Section 6.7.3.3 from bottom to top with the following:

7.5.3.1 2 g silica gel (Section 7.5.1.1)

7.5.3.2 2 g potassium silicate (Section 7.5.1.4)

7.5.3.3 2 g granular anhydrous sodium sulfate (Section 7.2.1)

7.5.3.4 10 g acid silica gel (Section 7.5.1.2)

7.5.3.5 2 g granular anhydrous sodium sulfate

7.5.4 Florisil column

7.5.4.1 Florisil—PR grade, 60-100 mesh (U.S. Silica Corp, Berkeley Springs, WV, or equivalent). Alternatively, prepacked Florisil columns may be used. Use the following procedure for Florisil activation and column packing.

7.5.4.1.1 Fill a clean 1- to 2-L bottle $\frac{1}{2}$ to $\frac{2}{3}$ full with Florisil and place in an oven at 130-150 °C for a minimum of three days to activate the Florisil.

7.5.4.1.2 Immediately prior to use, dry pack a 300-mm x 22-mm ID glass column (Section 6.7.3.3) bottom to top with 0.5-1.0 cm of warm to hot anhydrous sodium sulfate (Section 7.2.1), 10-10.5 cm of warm to hot activated Florisil (Section 7.5.4.1.1), and 1-2 cm of warm to hot anhydrous sodium sulfate. Allow the column to cool and wet immediately with 100 mL of n-hexane to prevent water from entering.

7.5.4.2 Using the procedure in Section 13.6.3, establish the elution pattern for each carton of Florisil or each lot of Florisil columns received.

7.6 Reference matrices—Matrices in which BDEs and interfering compounds are not detected by this Method

7.6.1 Reagent water—Bottled water purchased locally, or prepared by passage through activated carbon

7.6.2 High-solids reference matrix—Playground sand or similar material. Prepared by extraction with methylene chloride and/or baking at 450 °C for a minimum of 4 hours.

7.6.3 Paper reference matrix—Glass-fiber filter, Gelman type A, or equivalent. Cut paper to simulate the surface area of the paper sample being tested.

7.6.4 Tissue reference matrix—Corn or other vegetable oil.

7.6.5 Other matrices—This Method may be verified on any reference matrix by performing the tests given in Section 9.2. Ideally, the matrix should be free of the BDEs, but in no case must the background level of BDEs in the reference matrix exceed the minimum levels in Table 2. If low background levels of the BDEs are present in the reference matrix, the

spike level of the analytes used in Section 9.2 should be increased to provide a spike-to-background ratio of approximately 5 (Reference 11).

7.7 Standard solutions—Prepare from materials of known purity and composition or purchase as solutions or mixtures with certification to their purity, concentration, and authenticity. If the chemical purity is 98 % or greater, the weight may be used without correction to calculate the concentration of the standard. Observe the safety precautions in Section 5 and the recommendation in Section 5.1.2.

7.7.1 For preparation of stock solutions from neat materials, dissolve an appropriate amount of assayed reference material in solvent. For example, weigh 1 to 2 mg of BDE 99 to three significant figures in a 10-mL ground-glass-stoppered volumetric flask and fill to the mark with nonane. After the compound is completely dissolved, transfer the solution to a clean 15-mL vial with fluoropolymer-lined cap.

7.7.2 When not being used, store standard solutions in the dark at room temperature in screw-capped vials with fluoropolymer-lined caps. Place a mark on the vial at the level of the solution so that solvent loss by evaporation can be detected. Replace the solution if solvent loss has occurred.

7.8 Native (unlabeled) stock solutions

7.8.1 Native stock solution—Prepare to contain the native BDEs of primary interest (see Table 1, footnote 5) at the concentrations shown in Table 3. If additional BDEs are to be determined by multi-point calibration, include the additional native compounds in this stock solution.

7.8.2 Native BDE congener stock solutions—Solutions containing the native congeners to calibrate the DB-5HT column. If BDE congeners other than the BDEs of primary interest are to be determined, and co-elution of these congeners will occur, prepare stock solutions that will allow separation of the congeners on the DB-5HT column. For example, if it is desired to test for the congeners found in EPA's 2001 literature search and the congeners that will cover all levels of bromination (shown in italics and the footnotes in Table 1), prepare stocks of the 2 congener solutions in Table 4 at concentrations of 20 µg/mL each for all BDEs except DeBDE and at 200 µg/mL for DeBDE.

Note: If a column other than the DB-5HT column is used, solutions that allow separation of the congeners of interest on that column must be prepared.

7.8.2.1 Combined congener stock solution—Combine equal volumes of the solutions in Section 7.8.2 to form a stock solution containing all BDE congeners. Because 2 solutions are used, this solution will be at ½ the concentration of the 2 individual solutions.

7.8.3 Stock solutions should be checked for signs of degradation prior to the preparation of calibration or performance test standards. Reference standards that can be used to determine the accuracy of standard solutions are available from several vendors.

7.9 Labeled compound stock solutions

- 7.9.1 Labeled compound stock solution—Prepare in isooctane or nonane at the concentrations in Table 3. If additional BDEs are to be determined by isotope dilution, include the additional labeled compounds in this stock solution.
- 7.9.2 Labeled cleanup standard stock solution--Prepare labeled BDE 139L in iso-octane or nonane at the concentration shown in Table 3.
- 7.9.3 Labeled injection internal standard stock solution—Prepare labeled polychlorinated biphenyl (PCB) PCB-52L and PCB-138L in nonane or isooctane at the concentrations shown in Table 3.

7.10 Calibration standards

- 7.10.1 Calibration standards—Combine and dilute the solutions in Sections 7.8.1 and 7.9 to produce the calibration solutions in Table 5 for the CS-1 to CS-5 set of calibration solutions. These solutions permit the relative response (labeled to native) and response factor to be measured as a function of concentration. The CS-3 standard is used for calibration verification (VER).

7.10.2 Solutions of congener mixes

- 7.10.2.1 Diluted individual solutions—Required if congeners other than the BDEs of primary interest are to be determined.

- 7.10.2.1.1 The two individual solutions listed in Table 4, when analyzed individually, allow resolution of all of the BDE congeners on the DB-5HT column, and are used for establishing retention time and other data for each congener. The elution order of the congeners present in each of the solutions (Section 7.8.2.1) is given in Table 2.

- 7.10.2.1.2 Individually combine an aliquot of each individual mix stock solution (Section 7.8.2.1) with an aliquot of the labeled stock solution (Section 7.9.1), the labeled cleanup standard stock solution (Section 7.9.2), and the labeled injection internal standard stock solution (7.9.3) to produce concentrations of 50 and 500 ng/mL for MoBDE - NoBDE and DeBDE, respectively, for the native compounds; and 100 and 1000 ng/mL for MoBDE - NoBDE and DeBDE, respectively, for the labeled compounds, as shown in the "Extract" column in Table 3. The congeners will be at the same concentration as in the CS-3 (VER) calibration solution in Table 5.

- 7.10.2.2 Diluted combined congener solution—Required if BDEs other than the BDEs of primary interest are to be determined.

- 7.10.2.2.1 This solution combines the two individual mixes with the labeled compounds to allow single-point calibration of the congeners not included in the multi-point calibration, and establishes an average response factor for the co-eluting isomeric congeners.

7.10.2.2.2 Combine an aliquot of the combined BDE congener solution (Section 7.8.2.1) with an aliquot of the labeled stock solution (Section 7.9.1), the labeled cleanup standard stock solution (Section 7.9.2), and the labeled injection internal standard stock solution (7.9.3) to produce the same concentrations as in the diluted individual mix solutions (Section 7.10.2.1.2, the "Extract" column Table 3 and the CS-3 (VER) solution in Table 5).

- 7.11** Native standard spiking solution—Used for determining initial precision and recovery (IPR; Section 9.2) and ongoing precision and recovery (OPR; Section 15.5). Dilute the native stock solution (Section 7.8.1) with acetone to produce concentrations of MoBDE - NoBDE and DeBDE at 1.0 and 2.0 ng/mL, respectively, as shown in Table 3. When 1 mL of this solution spiked into the IPR (Section 9.2.1) or OPR (Section 15.5) and concentrated to a final volume of 20 μ L, the concentrations in the final volume will be 50 and 500 ng/mL (pg/ μ L). Prepare only the amount necessary for each reference matrix with each sample batch.
- 7.12** Labeled standard spiking solution—This solution is spiked into each sample (Section 9.3) and into the IPR (Section 9.2.1), OPR (Section 15.5), and blank (Section 9.5) to measure recovery. Dilute the labeled stock solution (Section 7.9.1) with acetone to produce concentrations of labeled Mo-BDE - NoBDE and DeBDE, respectively, at 2.0 and 20 ng/mL, as shown in Table 3. When 1 mL of this solution is spiked into an IPR, OPR, blank, or sample and concentrated to a final extract volume of 20 μ L, the concentrations in the final volume will be 100 and 1000 ng/mL (pg/ μ L). Prepare only the amount necessary for each reference matrix with each sample batch.
- 7.13** Labeled cleanup standard spiking solution—This solution is spiked into each extract prior to cleanup to measure the efficiency of the cleanup process. Dilute the labeled cleanup standard stock solution (Section 7.9.2) in methylene chloride to produce a concentration of the cleanup standard at 2.0 ng/mL, as shown in Table 3. When 1.0 mL of this solution is spiked into a sample extract and concentrated to a final volume of 20 μ L, the concentration in the final volume will be 100 ng/mL (pg/ μ L).
- 7.14** Labeled injection internal standard spiking solution—This solution is added to each concentrated extract prior to injection into the HRGC/HRMS. Dilute the labeled injection internal standard stock solution (Section 7.9.3) in nonane to produce a concentration of the injection internal standards at 1000 ng/mL, as shown in Table 3. When 2 μ L of this solution is spiked into a 20 μ L extract, the concentration of each injection internal standard will be nominally 100 ng/mL (pg/ μ L).

Note: The addition of 2 μ L of the labeled injection internal standard spiking solution to a 20 μ L final extract has the effect of diluting the concentration of the components in the extract by 10%. Provided all calibration solutions and all extracts undergo this dilution as a result of adding the labeled injection internal standard spiking solution, the effect of the 10% solution is compensated, and correction for this dilution should not be made.

- 7.15** QC Check Sample—A QC Check Sample should be obtained from a source independent of the calibration standards. Ideally, this check sample would be a Standard Reference Material (SRM) containing the BDEs in known concentrations in a sample matrix similar to the matrix under test.
- 7.16** Stability of solutions—Standard solutions used for quantitative purposes (Sections 7.9 through 7.14) should be assayed periodically (e.g., every 6 months) against SRMs from NIST

(if available), or certified reference materials from a source that will attest to the authenticity and concentration, to assure that the composition and concentrations have not changed.

8.0 Sample collection, preservation, storage, and holding times

8.1 Collect samples in amber glass containers following conventional sampling practices (Reference 12).

8.2 Aqueous samples

8.2.1 Collect samples that flow freely as grab samples or in refrigerated bottles using automatic sampling equipment.

8.2.2 If residual chlorine is present, add 80 mg sodium thiosulfate per liter of water. EPA Methods 330.4 and 330.5 may be used to measure residual chlorine (Reference 13).

8.2.3 Maintain aqueous samples in the dark at $<6^{\circ}\text{C}$ from the time of collection until receipt at the laboratory. If the sample will be frozen, allow room for expansion. Store in the dark at $<6^{\circ}\text{C}$.

8.3 Solid, mixed-phase, semi-solid, and oily samples, excluding tissue

8.3.1 Collect samples as grab samples using wide-mouth jars.

8.3.2 Maintain solid, semi-solid, oily, and mixed-phase samples in the dark at $<6^{\circ}\text{C}$ from the time of collection until receipt at the laboratory. Store solid, semi-solid, oily, and mixed-phase samples in the dark at $<-10^{\circ}\text{C}$.

8.4 Fish and other tissue samples

8.4.1 Fish may be cleaned, filleted, or processed in other ways in the field, such that the laboratory may expect to receive whole fish, fish fillets, or other tissues for analysis.

8.4.2 Collect fish, wrap in aluminum foil, and maintain at $<6^{\circ}\text{C}$ from the time of collection until receipt at the laboratory, to a maximum of 24 hours. If a longer transport time is necessary, freeze the sample. Ideally, fish should be frozen upon collection and shipped to the laboratory under dry ice.

8.4.3 Freeze tissue samples upon receipt at the laboratory and maintain in the dark at $<-10^{\circ}\text{C}$ until prepared. Maintain unused sample in the dark at $<-10^{\circ}\text{C}$.

8.5 Holding times

8.5.1 There are no demonstrated maximum holding times associated with the BDEs in aqueous, solid, semi-solid, tissue, or other sample matrices. If stored in the dark at $<6^{\circ}\text{C}$, aqueous samples may be stored for up to one year. Similarly, if stored in the dark at less than -10°C , solid, semi-solid, multi-phase, and tissue samples may be stored for up to one year.

8.5.2 Store sample extracts in the dark at less than -10°C until analyzed. If stored in the dark at less than -10°C , sample extracts may be stored for up to one year.

9.0 Quality assurance/quality control

9.1 Each laboratory that uses this Method is required to operate a formal quality assurance program (Reference 14). The minimum requirements of this program consist of an initial demonstration of laboratory capability, analysis of samples spiked with labeled compounds to evaluate and document data quality, and analysis of standards and blanks as tests of continued performance. Laboratory performance is compared to established performance criteria to determine if the results of analyses meet the performance characteristics of this Method. If this Method is to be applied to a sample matrix other than water (e.g., soil, filter cake, compost, tissue) the most appropriate alternate reference matrix (Sections 7.6.2 - 7.6.5 and 7.15) is substituted for the reagent water matrix (Section 7.6.1) in all performance tests.

9.1.1 The laboratory must make an initial demonstration of the ability to generate acceptable precision and recovery with this Method. This demonstration is given in Section 9.2.

9.1.2 In recognition of advances that are occurring in analytical technology, and to overcome matrix interferences, the laboratory is permitted certain options to improve separations or lower the costs of measurements. These options include alternate extraction, concentration, and cleanup procedures, and changes in columns and detectors. Alternate determinative techniques, such as substitution of spectroscopic or immunoassay techniques, and changes that degrade Method performance, are not allowed. If an analytical technique other than the techniques specified in this Method is used, that technique must have a specificity equal to or greater than the specificity of the techniques in this Method for the analytes of interest.

9.1.2.1 Each time a modification is made to this Method, the laboratory is required to repeat the procedure in Section 9.2. If the detection limit of the Method will be affected by the change, the laboratory is required to demonstrate that the MDLs (40 CFR 136, Appendix B) are lower than one-third the regulatory compliance limit or one-third the EMDLs in this Method, whichever are greater. If calibration will be affected by the change, the instrument must be recalibrated per Section 10.

9.1.2.2 The laboratory is required to maintain records of modifications made to this Method. These records include the following, at a minimum:

9.1.2.2.1 The names, titles, addresses, and telephone numbers of the analyst(s) that performed the analyses and modification, and of the quality control officer that witnessed and will verify the analyses and modification.

9.1.2.2.2 A list of pollutant(s) measured, by name and CAS Registry number.

9.1.2.2.3 A narrative stating reason(s) for the modification.

9.1.2.2.4 Results from all quality control (QC) tests comparing the modified method to this Method, including:

- a) Calibration (Section 10).
- b) Calibration verification (Section 15.3).
- c) Initial precision and recovery (Section 9.2).
- d) Labeled compound recovery (Section 9.3).
- e) Analysis of blanks (Section 9.5).

- f) Accuracy assessment (Section 9.4).

- 9.1.2.2.5** Data that will allow an independent reviewer to validate each determination by tracing the instrument output (peak height, area, or other signal) to the final result. These data are to include:
 - a) Sample numbers and other identifiers.
 - b) Extraction dates.
 - c) Analysis dates and times.
 - d) Analysis sequence/run chronology.
 - e) Sample weight or volume (Section 11).
 - f) Extract volume prior to each cleanup step (Section 13).
 - g) Extract volume after each cleanup step (Section 13).
 - h) Final extract volume prior to injection (Section 14).
 - i) Injection volume (Section 14.3).
 - j) Dilution data, differentiating between dilution of a sample or extract (Section 17.5).
 - k) Instrument and operating conditions.
 - l) Column (dimensions, liquid phase, solid support, film thickness, etc).
 - m) Operating conditions (temperatures, temperature program, flow rates).
 - n) Detector (type, operating conditions, etc).
 - o) Chromatograms, printer tapes, and other recordings of raw data.
 - p) Quantitation reports, data system outputs, and other data to link the raw data to the results reported.

9.1.2.3 Alternate GC column or column system—See Section 6.9.1.3.

- 9.1.3** Analyses of method blanks are required to demonstrate freedom from contamination (Section 4.3). The procedures and criteria for analysis of a method blank are given in Sections 9.5 and 15.6.

- 9.1.4** The laboratory must spike all samples with labeled compounds to monitor Method performance. This test is described in Section 9.3. When results of these spikes indicate atypical Method performance for samples, the samples are diluted to bring Method performance within acceptable limits. Procedures for dilution are given in Section 17.5.

- 9.1.5** The laboratory must, on an ongoing basis, demonstrate through calibration verification and analysis of the ongoing precision and recovery standard (OPR) and blanks that the analytical system is in control. These procedures are given in Sections 15.1 through 15.6.

- 9.1.6** The laboratory should maintain records to define the quality of data generated. Development of accuracy statements is described in Section 9.4.

9.2 Initial precision and recovery (IPR)—To establish the ability to generate acceptable precision and recovery, the laboratory must perform the following operations.

- 9.2.1** For low solids (aqueous) samples, extract, concentrate, and analyze four 1-L aliquots of reagent water spiked with 1 mL each of the native spiking solution (Section 7.11) and the labeled standard spiking solution (Section 7.12), and spike the extracts with the labeled cleanup standard spiking solution (Section 7.13), according to the procedures in Sections 11 through 18. For an alternate sample matrix, four aliquots of the alternate reference matrix (Section 7.6) are used. All sample processing steps that are to be used for

processing samples, including preparation (Section 11), extraction (Section 12), and cleanup (Section 13), must be included in this test.

- 9.2.2** Using results of the set of four analyses, compute the percent recovery for each BDE in each analysis, the average percent recovery (X) for each BDE in the four analyses, and the standard deviation of the percent recoveries (relative standard deviation; RSD) for each compound, by isotope dilution for BDEs with a labeled analog, and by internal standard for BDEs without a labeled analog and for the labeled compounds.
- 9.2.3** For each BDE and labeled compound, compare RSD and X with the corresponding limits for initial precision and recovery in Table 6. If RSD and X for all compounds meet the acceptance criteria, system performance is acceptable and analysis of blanks and samples may begin. If, however, any individual RSD exceeds the precision limit or any individual X falls outside the range for recovery, system performance is unacceptable for that compound. Correct the problem and repeat the test (Section 9.2).
- 9.3** To assess Method performance on the sample matrix, the laboratory must spike all samples with the labeled standard spiking solution (Section 7.12) and all sample extracts with the labeled cleanup standard spiking solution (Section 7.13).
- 9.3.1** Analyze each sample according to the procedures in Sections 11 through 18.
- 9.3.2** Compute the percent recovery of the labeled congeners and the labeled cleanup congener using the internal standard method (Section 17.2).
- 9.3.3** The recovery of each labeled compound must be within the limits in Table 6. If the recovery of any compound falls outside of these limits, Method performance is unacceptable for that compound in that sample. Additional cleanup procedures must then be employed to attempt to bring the recovery within the normal range. If the recovery cannot be brought within the normal range after all cleanup procedures have been employed, water samples are diluted and smaller amounts of soils, sludges, sediments, and other matrices are analyzed per Section 18.
- 9.4** It is suggested but not required that recovery of labeled compounds from samples be assessed and records maintained.
- 9.4.1** After the analysis of 30 samples of a given matrix type (water, soil, sludge, pulp, etc.) for which the labeled compounds pass the tests in Section 9.3, compute the average percent recovery (R) and the standard deviation of the percent recovery (S_R) for the labeled compounds only. Express the assessment as a percent recovery interval from $R - 2S_R$ to $R + 2S_R$ for each matrix. For example, if $R = 90\%$ and $S_R = 10\%$ for five analyses of pulp, the recovery interval is expressed as 70 to 110%.
- 9.4.2** Update the accuracy assessment for each labeled compound in each matrix on a regular basis (e.g., after each five to ten new measurements).
- 9.5** Method blanks—A reference matrix method blank is analyzed with each sample batch (Section 4.3) to demonstrate freedom from contamination. The matrix for the method blank must be similar to the sample matrix for the batch, e.g., a 1-L reagent water blank (Section 7.6.1), high-solids reference matrix blank (Section 7.6.2), paper matrix blank (Section 7.6.3); tissue blank (Section 7.6.4), or alternative reference matrix blank (Section 7.6.5).

- 9.5.1** Spike 1.0 mL of the labeled standard spiking solution (Section 7.12) into the method blank and 1 mL the labeled cleanup standard spiking solution (Section 7.13) into the extract of the method blank, according to the procedures in Sections 11 through 18. Prepare, extract, clean up, and concentrate the method blank. Analyze the blank immediately after analysis of the OPR (Section 15.5) to demonstrate freedom from contamination.
- 9.5.2** If any BDE (Table 1) is found in the blank at greater than the minimum level (Table 2) or one-third the regulatory compliance limit, whichever is greater; or if any potentially interfering compound is found in the blank at the ML for each BDE given in Table 2 (assuming a response factor of 1 relative to the quantitation reference in Table 2 at that level of bromination for a potentially interfering compound; i.e., a compound not listed in this Method), analysis of samples must be halted until the sample batch is re-extracted and the extracts re-analyzed, and the blank associated with the sample batch shows no evidence of contamination at these levels. All samples must be associated with an uncontaminated method blank before the results for those samples may be reported or used for permitting or regulatory compliance purposes.
- 9.6** QC Check Sample—The laboratory should analyze a QC check sample (Section 7.15) periodically to assure the accuracy of calibration standards and the overall reliability of the analytical process. It is suggested that the QC check sample be analyzed at least quarterly.
- 9.7** The specifications contained in this Method can be met if the apparatus used is calibrated properly and maintained in a calibrated state. The standards used for calibration (Section 10), calibration verification (Section 15.3), and for initial (Section 9.2) and ongoing (Section 15.5) precision and recovery should be identical, so that the most precise results will be obtained. The HRGC/HRMS instrument will provide the most reproducible results if dedicated to the settings and conditions required for determination of BDEs by this Method.
- 9.8** Depending on specific program requirements, field replicates may be collected to determine the precision of the sampling technique, and spiked samples may be required to determine the accuracy of the analysis when the internal standard method is used.

10.0 Calibration

- 10.1** Establish the operating conditions necessary to meet the retention times (RTs) and relative retention times (RRTs) for the BDEs in Table 2.
- 10.1.1** Suggested GC operating conditions:
- Injector temperature: 300 °C
 - Interface temperature: 320 °C
 - Initial temperature: 100 °C
 - Initial time: 3 minutes
 - Temperature program: 100 - 320 °C @ 5 °C/minute
 - Final time: 5 minutes

All portions of the column that connect the GC to the ion source should remain at or above the interface temperature specified above during analysis to preclude condensation of less volatile compounds.

The GC conditions may be optimized for compound separation and sensitivity. Once optimized, the same GC conditions must be used for analysis of all standards, blanks, IPR and OPR standards, and samples.

10.1.2 Retention time calibration for the BDE congeners

10.1.2.1 If only the eight BDEs of primary interest are to be analyzed, inject the CS-3 calibration solution (Section 7.10.1 and Table 5). If congeners in addition to the BDEs of primary interest are to be analyzed, separately inject each of the diluted individual congener solutions (Section 7.10.2.1.2). Establish the beginning and ending retention times at each level of bromination for the scan descriptors in Table 7. Scan descriptors other than those listed in Table 7 may be used provided the MDLs in Table 2 are met. Store the retention time (RT) and relative retention time (RRT) for each congener in the data system.

10.1.2.2 The absolute retention time of BDE 209 must exceed 48 minutes on the DB-5HT column; otherwise, the GC temperature program must be adjusted and this test repeated until the minimum retention time criterion is met. If a GC column or column system alternate to the DB-5HT column is used, a similar minimum retention time specification must be established for the alternate column or column systems so that interferences that may be encountered in environmental samples will be resolved from the analytes of interest. This specification is deemed to be met if the retention time of BDE 209 is greater than 48 minutes on such alternate column.

10.1.2.3 If BDEs other than the eight BDEs of primary interest are to be determined, inject the Diluted combined congener solution (Section 7.10.2.2); otherwise, use the data from injection of the CS-3 calibration solution (Section 10.1.2.1). Adjust the chromatographic conditions and scan descriptors until the specifications for the one- or two-column system in Section 6.9.1.1.1 - 6.9.1.1.4 or 6.9.1.2.1 - 6.9.1.2.3, respectively, are met. If an alternate column or column system is used, adjust the conditions for that column. If column performance is unacceptable, optimize the analysis conditions or replace the column and repeat the performance tests. Confirm that the scan descriptor changes at times when BDEs do not elute.

10.1.2.4 After the column performance tests are passed (Section 10.1.2.2 - 10.1.2.3), store the RTs and RRTs for the resolved congeners and the RTs and RRTs for the isomeric congeners that co-elute.

10.1.3 GC and Temperature-Programmed Injector Conditions - Optional to prevent breakdown of octa, nona and deca congeners and improve recovery. These conditions are optimized to target minimization of BDE-209 breakdown, while attempting to resolve and quantitate as many of the other target BDE congeners as possible.

GC Column:

15 m DB-5ms, 0.25 mm x 0.1 μ m film
Constant Helium flow at 1.5 mL/min

TPI Injector:

Sample Injection Volume: 5 μ L
Vent Flow: 100 mL/min

Vent Pressure: 2 psi until 0.75 min
Pure Flow to Spit Vent: 500 mL/min at 5 min
Temperature Program: 45 °C for 0.8 min, 600 °C/min to 330 °C, hold for 20 min
GC Temperature Program:
40 ° for 1.5 min
45 °C/min to 140 °C
5 °C/min to 310 °C, hold for 8.0 min
Total Run Time: 45.72 min

10.2 Mass spectrometer (MS) resolution

10.2.1 Using perfluorokerosene (or other reference substance) and a molecular leak, tune the instrument to meet a resolving power of 5,000 (10% valley) at m/z 554.9665 or any other significant fragment in the range of 540 to 580. For each descriptor (Table 7), monitor and record the resolution and exact m/z s of three to five reference peaks covering the mass range of the descriptor. The level of reference substance metered into the HRMS during analyses should be adjusted so that the amplitude of the most intense selected lock-mass m/z signal (regardless of the descriptor number) does not exceed 10% of the full-scale deflection for a given set of detector parameters. Under those conditions, sensitivity changes that might occur during the analysis can be more effectively monitored.

Note: Different lots and types of reference substance can contain varying levels of contamination, and an excessive amount of reference substance may cause noise problems and contamination of the ion source necessitating increased frequency of source cleaning.

10.2.2 The analysis time for BDEs may exceed the long-term mass stability of the mass spectrometer. Because the instrument is operated in the high-resolution mode, a mass drift of a few ppm (e.g., 5 ppm in mass) can have a serious adverse effect on instrument performance. Therefore, mass-drift correction is mandatory and a lock-mass m/z from PFK or other reference substance is used for drift correction. The lock-mass m/z is dependent on the exact m/z s monitored within each descriptor, as shown in Table 7. The deviation between each exact m/z monitored and the theoretical m/z (Table 7) must be less than 5 ppm.

10.2.3 Obtain a selected ion current profile (SICP) at the two exact m/z s specified in Table 7 and at $\geq 5,000$ resolving power at each level of bromination (LOB) for the native congeners and congener groups and for the labeled congeners. Because of the extensive mass range covered in each function and the requirement for $\geq 5,000$ resolution throughout the mass range during the function, the resolution may need to be greater than 5,000 in the center of the mass range for each function.

10.2.4 If the HRMS has the capability to monitor resolution during the analysis, it is acceptable to terminate the analysis when the resolution falls below the minimum (Section 10.2.3) to save analysis time.

10.3 Ion abundance ratios, minimum levels, and signal-to-noise (S/N) ratios. Choose an injection volume of either 1 or 2 μL , consistent with the capability of the HRGC/HRMS instrument. Inject a 1 or 2 μL aliquot of the CS-1 calibration solution (Table 5) using the GC conditions in Section 10.1.1.

10.3.1 Measure the SICP areas for each congener or congener group, and compute the ion abundance ratios at the exact m/zs specified in Table 7. Compare the computed ratio to the theoretical ratio given in Table 8.

10.3.1.1 The exact m/zs to be monitored in each descriptor are shown in Table 7. Each group or descriptor must be monitored in succession as a function of GC retention time to ensure that the BDEs of interest are detected. Additional m/zs may be monitored in each descriptor, and the m/zs may be divided among more than the descriptors listed in Table 7, provided that the laboratory is able to monitor the m/zs of all BDEs that elute from the GC in a given level of bromination (LOB) window. The laboratory must also monitor exact m/zs for congeners at higher LOBs to determine if fragments will compromise measurement of congeners at lower LOBs.

10.3.1.2 The mass spectrometer must be operated in a mass-drift correction mode, using a reference substance to provide lock m/zs. The lock mass for each group of m/zs is shown in Table 7. Each lock mass must be monitored and must not vary by more than $\pm 20\%$ throughout its respective retention time window. Variations of lock mass by more than 20% indicate the presence of co-eluting interferences that raise the source pressure and may significantly reduce the sensitivity of the mass spectrometer. Re-injection of another aliquot of the sample extract may not resolve the problem and additional cleanup of the extract may be required to remove the interference. A lock mass interference or suppression in a retention time region in which BDEs and labeled compounds do not elute may be ignored.

10.3.2 All BDEs and labeled compounds in the CS-1 standard must be within the QC limits in Table 8 for their respective ion abundance ratios; otherwise, the mass spectrometer must be adjusted and this test repeated until the m/z ratios fall within the limits specified. If the adjustment alters the resolution of the mass spectrometer, resolution must be verified (Section 10.2.1) prior to repeat of the test.

10.3.3 Verify that the HRGC/HRMS instrument meets the minimum levels (MLs) in Table 2. The peaks representing the BDEs and labeled compounds in the CS-1 calibration standard must have $S/Ns \geq 10$; otherwise, the mass spectrometer must be adjusted and this test repeated until the minimum levels in Table 2 are met.

Note: The MDLs and MLs in Table 2 are based on the levels of contamination normally found in laboratories. Lower levels may be readily achievable if segregation and extensive cleaning of glassware are employed. If lower levels are achievable, these levels must be established as described in Section 17.6.1.4.1.

10.4 Calibration by isotope dilution—Isotope dilution is used for calibration of the BDEs that have a labeled analog. The reference compound for each native compound its labeled analog, as listed in Table 2. A 5-point calibration encompassing the concentration range is prepared for each native congener.

10.4.1 For the native BDEs determined by isotope dilution, the relative response (RR) (labeled to native) vs. concentration in the calibration solutions (Table 5) is computed over the calibration range according to the procedures described below.

- 10.4.2** The response of each native BDE relative to its labeled analog is determined using the area responses of both the primary and secondary exact m/zs specified in Table 7, for each calibration standard, as follows:

$$RR = (A1_n + A2_n) C_l / (A1_l + A2_l) C_n$$

where:

A1_n and A2_n = The measured areas at the primary and secondary m/zs for the BDE

A1_l and A2_l = The measured areas at the primary and secondary m/zs for the labeled compound

C_l = The concentration of the labeled compound in the calibration standard (Table 5)

C_n = The concentration of the native compound in the calibration standard (Table 5)

- 10.4.3** To calibrate the instrument for the BDEs of primary interest by isotope dilution, inject calibration standards CS-1 through CS-5 (Section 7.10.1 and Table 5). Use a volume identical to the volume chosen in Section 10.3, the procedure in Section 14, and the conditions in Section 10.1.1. Compute and store the relative response (RR) for each native BDE at each concentration. Compute the average (mean) RR and the RSD of the 5 RRs.

- 10.4.4** Linearity—If the RR for any BDE is constant (less than 20% RSD), the average RR may be used for that congener; otherwise, the complete calibration curve for that congener must be used over the calibration range.

10.5 Calibration by internal standard

- 10.5.1** Internal standard calibration is applied to determination of the native BDEs for which a labeled compound is not available, to determination of the labeled congeners and labeled cleanup standard for performance tests and intra-laboratory statistics (Sections 9.4 and 15.5.4), and to determination of the labeled injection internal standards except for PCB 138L. The reference for each congener is listed in Table 2.

- 10.5.2** Response factors—Internal standard calibration requires the determination of response factors (RF) defined by the following equation:

$$RF = (A1_s + A2_s) C_{is} / (A1_{is} + A2_{is}) C_s$$

where:

A1_s and A2_s = The measured areas at the primary and secondary m/zs for the BDE

A1_{is} and A2_{is} = The measured areas at the primary and secondary m/zs for the internal standard

C_{is} = The concentration of the internal standard (Table 5)

C_s = The concentration of the compound in the calibration standard (Table 5)

- 10.5.3** Compute the response factor (RF) for all native BDEs except those that have a labeled analog. Use the average (mean) response of the labeled compounds at each level of bromination (LOB) as the quantitation reference, as shown in Table 2. For the combinations of isomeric congeners that co-elute, compute a combined RF for the co-eluted group. For example, for congener 116, the areas at the two exact m/zs for 99L, 100L, and 126L are summed and the total area is divided by 3 (because there are 3 congeners as the quantitation reference).

Note: All labeled congeners at each LOB are used as reference to reduce the effect of interferences. Other quantitation references and procedures may be used provided that the results produced are as accurate as results produced by the quantitation references and procedures described in this method.

- 10.5.4** For the labeled compounds and the labeled cleanup standards, use the nearest eluted labeled injection internal standard as the quantitation reference, as given in Table 2. Labeled injection internal standard PCB 52L is referenced to PCB 138L, and PCB 138L is referenced to itself, as shown in Table 2.
- 10.5.5** Multi-point calibration—Calibrate the instrument for compounds to be multi-point calibrated (other than those calibrated by isotope dilution) using data from the injections performed for isotope dilution calibration (Section 10.4.3).
- 10.5.6** Linearity—If the RF for any compound is constant (less than 35% RSD for all congeners other than congener 209L; less than 100% for congener 209L), an average RF may be used for that compound; otherwise, a calibration curve must be used for that compound.
- 10.5.7** Single-point calibration—Calibrate the instrument for any additional native BDEs by injecting the diluted combined congener solution (Section 7.10.2.2).

11.0 Sample preparation

- 11.1** Sample preparation involves modifying the physical form of the sample so that the BDEs can be extracted efficiently. In general, the samples must be in a liquid form or in the form of finely divided solids in order for efficient extraction to take place. Table 9 lists the phases and suggested quantities for extraction of various sample matrices.

For samples known or expected to contain high levels of the BDEs, the smallest sample size representative of the entire sample should be used (see Section 18). For all samples, the blank and IPR/OPR aliquots must be processed through the same steps as the sample to check for contamination and losses in the preparation processes.
- 11.1.1** For samples that contain particles, percent solids and particle size are determined using the procedures in Sections 11.2 and 11.3, respectively.
- 11.1.2** Aqueous samples—Because BDEs may be bound to suspended particles, the preparation of aqueous samples is dependent on the solids content of the sample.
 - 11.1.2.1** Aqueous samples containing one percent solids or less are prepared per Section 11.4 and extracted directly using one of the extraction techniques in Section 12.2.
 - 11.1.2.2** For aqueous samples containing greater than one percent solids, a sample aliquot sufficient to provide 10 g of dry solids is used, as described in Section 11.5.
- 11.1.3** Solid samples are prepared using the procedure in Section 11.5 followed by extraction using the SDS procedure in Section 12.3.
- 11.1.4** Multi-phase samples—The phase(s) containing the BDEs is separated from the non-BDE phase using pressure filtration and centrifugation, as described in Section 11.6. The

BDEs will be in the organic phase in a multi-phase sample in which an organic phase exists.

11.1.5 Procedures for grinding, homogenization, and blending of various sample phases are given in Section 11.7.

11.1.6 Tissue samples—Preparation procedures for fish and other tissues are given in Section 11.8.

11.2 Determination of percent suspended solids. This aliquot is used for determining the solids content of the sample, not for determination of BDEs.

11.2.1 Aqueous liquids and multi-phase samples consisting of mainly an aqueous phase.

11.2.1.1 Desiccate and weigh a GF/D filter (Section 6.5.3) to three significant figures.

11.2.1.2 Filter 10.0 ± 0.02 mL of well-mixed sample through the filter.

11.2.1.3 Dry the filter a minimum of 12 hours at 110 ± 5 °C and cool in a desiccator.

11.2.1.4 Calculate percent solids as follows:

$$\% \text{ solids} = 100 (\text{weight of sample aliquot after drying (g)} - \text{weight of filter (g)}) / 10 \text{ g}$$

11.2.2 Non-aqueous liquids, solids, semi-solid samples, and multi-phase samples in which the main phase is not aqueous; but not tissues.

11.2.2.1 Weigh a 5- to 10-g aliquot of sample to three significant figures in a tared beaker.

11.2.2.2 Dry a minimum of 12 hours at 110 ± 5 °C, and cool in a desiccator.

11.2.2.3 Calculate percent solids as follows:

$$\% \text{ solids} = 100 \text{ weight of aliquot after drying (g)} / \text{weight of aliquot before drying (g)}$$

11.3 Estimation of particle size

11.3.1 Spread the dried sample from Section 11.2.2.2 on a piece of filter paper or aluminum foil in a fume hood or glove box.

11.3.2 Estimate the size of the particles in the sample. If the size of the largest particles is greater than 1 mm, the particle size must be reduced to 1 mm or less prior to extraction using the procedures in Section 11.7.

11.4 Preparation of aqueous samples containing one percent suspended solids or less.

11.4.1 Prepare using the procedure below and extract using the one of the extraction techniques in Section 12.2.

11.4.2 Preparation of sample and QC aliquots

- 11.4.2.1 Mark the original level of the sample on the sample bottle for reference. Weigh the sample plus bottle to ± 1 g.
- 11.4.2.2 Spike 1.0 mL of the labeled standard spiking solution (Section 7.12) into the sample bottle. Cap the bottle and mix the sample by shaking. Allow the sample to equilibrate for 1 to 2 hours, with occasional shaking.
- 11.4.2.3 For each sample or sample batch (to a maximum of 20 samples) to be extracted during the same 12-hour shift, place two 1.0-L aliquots of reagent water in clean sample bottles or flasks.
- 11.4.2.4 Spike 1.0 mL of the labeled standard spiking solution (Section 7.12) into both reagent water aliquots. Spike 1.0 mL of the native standard spiking solution (Section 7.11) into one reagent water aliquot. This aliquot will serve as the OPR (Section 15.5). The other aliquot will serve as the method blank.
- 11.4.2.5 For extraction using SPE, add 5 mL of methanol to the sample and QC aliquots. Cap and shake the sample and QC aliquots to mix thoroughly, and proceed to Section 12.2 for extraction.

11.5 Preparation of samples containing greater than one percent solids

- 11.5.1 Weigh a well-mixed aliquot of each sample (of the same matrix type) sufficient to provide 10 g of dry solids (based on the solids determination in Section 11.2) into a clean beaker or glass jar.
- 11.5.2 Spike 1.0 mL of the labeled standard spiking solution (Section 7.12) into the sample.
- 11.5.3 For each sample or sample batch (to a maximum of 20 samples) to be extracted during the same 12 hour shift, weigh two 10-g aliquots of the appropriate reference matrix (Section 7.6) into clean beakers or glass jars.
- 11.5.4 Spike 1.0 mL of the labeled standard spiking solution (Section 7.12) into both reference matrix aliquots. Spike 1.0 mL of the native standard spiking solution (Section 7.11) into one reference matrix aliquot. This aliquot will serve as the OPR (Section 15.5). The other aliquot will serve as the method blank.
- 11.5.5 Stir or tumble and equilibrate the aliquots for 1 to 2 hours.
- 11.5.6 Decant excess water. If necessary to remove water, filter the sample through a glass-fiber filter and discard the aqueous liquid.
- 11.5.7 If particles >1 mm are present in the sample (as determined in Section 11.3.2), spread the sample on clean aluminum foil in a hood. Observe the precaution in Section 5.3.1. After the sample is dry, grind to reduce the particle size (Section 11.7).
- 11.5.8 Extract the sample and QC aliquots using the SDS procedure in Section 12.3.

11.6 Multi-phase samples

- 11.6.1** Using the percent solids determined in Section 11.2.1 or 11.2.2, determine the volume of sample that will provide 10 g of solids, up to 1 L of sample.
- 11.6.2** Spike 1.0 mL of the labeled standard spiking solution (Section 7.12) into the amount of sample determined in Section 11.6.1, and into the OPR and blank. Spike 1.0 mL of the native standard spiking solution (Section 7.11) into the OPR. Pressure filter the sample, blank, and OPR through Whatman GF/D glass-fiber filter paper (Section 6.5.3). If necessary to separate the phases and/or settle the solids, centrifuge these aliquots prior to filtration.
- 11.6.3** Discard any aqueous phase (if present). Remove any non-aqueous liquid present and reserve the maximum amount filtered from the sample (Section 11.6.1) or 10 g, whichever is less, for combination with the solid phase (Section 12.3.5).
- 11.6.4** If particles >1 mm are present in the sample (as determined in Section 11.3.2) and the sample is capable of being dried, spread the sample and QC aliquots on clean aluminum foil in a hood. Observe the precaution in Section 5.3.1.
- 11.6.5** After the aliquots are dry or if the sample cannot be dried, reduce the particle size using the procedures in Section 11.7 and extract the reduced-size particles using the SDS procedure in Section 12.3. If particles >1 mm are not present, extract the particles and filter in the sample and QC aliquots directly using the SDS procedure in Section 12.3.
- 11.7** Sample grinding, homogenization, or blending—Samples with particle sizes greater than 1 mm (as determined in Section 11.3.2) are subjected to grinding, homogenization, or blending. The method of reducing particle size to less than 1 mm is matrix-dependent. In general, hard particles can be reduced by grinding with a mortar and pestle. Softer particles can be reduced by grinding in a Wiley mill or meat grinder, by homogenization, or in a blender.
- 11.7.1** Each size-reducing preparation procedure on each matrix must be verified by running the tests in Section 9.2 before the procedure is applied to samples and employed routinely.
- 11.7.2** The grinding, homogenization, or blending procedures must be carried out in a glove box or fume hood to prevent particles from contaminating the work environment.
- 11.7.3** Grinding—Certain papers and pulps, slurries, and amorphous solids can be ground in a Wiley mill or heavy duty meat grinder. In some cases, reducing the temperature of the sample to freezing or to dry ice or liquid nitrogen temperatures can aid in the grinding process. Grind the sample aliquots from Sections 11.5.7 or 11.6.5 in a clean grinder. Do not allow the sample temperature to exceed 50 °C. Grind the blank and reference matrix aliquots using a clean grinder.
- 11.7.4** Homogenization or blending—Particles that are not ground effectively, or particles greater than 1 mm in size after grinding, can often be reduced in size by high speed homogenization or blending. Homogenize and/or blend the particles or filter from Sections 11.5.7 or 11.6.5 for the sample, blank, and OPR aliquots.
- 11.7.5** Extract the aliquots using the SDS procedure in Section 12.3.

11.8 Fish and other tissues—Prior to processing tissue samples, the laboratory must determine the exact tissue to be analyzed. Common requests for analysis of fish tissue include whole fish-skin on, whole fish-skin removed, edible fish fillets (filleted in the field or by the laboratory), specific organs, and other portions. Once the appropriate tissue has been determined, the sample must be homogenized.

11.8.1 Homogenization

11.8.1.1 Samples are homogenized while still frozen, where practical. If the laboratory must dissect the whole fish to obtain the appropriate tissue for analysis, the unused tissues may be rapidly refrozen and stored in a clean glass jar for subsequent use.

11.8.1.2 Each analysis requires 10 g of tissue (wet weight). Therefore, the laboratory should homogenize at least 20 g of tissue to allow for re-extraction of a second aliquot of the same homogenized sample, if re-analysis is required. When whole fish analysis is necessary, the entire fish is homogenized.

11.8.1.3 Homogenize the sample in a tissue homogenizer (Section 6.3.3) or grind in a meat grinder (Section 6.3.4). Cut tissue too large to feed into the grinder into smaller pieces. To assure homogeneity, grind a minimum of three times.

11.8.1.4 Transfer approximately 10 g (wet weight) of homogenized tissue to a clean, tared, 400- to 500-mL beaker.

11.8.1.5 Transfer the remaining homogenized tissue to a clean jar with a fluoropolymer-lined lid. Seal the jar and store the tissue at less than -10 °C. Return any tissue that was not homogenized to its original container and store at less than -10 °C.

11.8.2 QC aliquots

11.8.2.1 Prepare a method blank by adding approximately 1-2 g of the oily liquid reference matrix (Section 7.6.4) to a 400- to 500-mL beaker.

11.8.2.2 Prepare a precision and recovery aliquot by adding 1-2 g of the oily liquid reference matrix (Section 7.6.4) to a separate 400- to 500-mL beaker. Record the weight to the nearest 10 mg. If the initial precision and recovery test is to be performed, use four aliquots; if the ongoing precision and recovery test is to be performed, use a single aliquot.

11.8.3 Spiking

11.8.3.1 Spike 1.0 mL of the labeled standard spiking solution (Section 7.12) into the sample, blank, and OPR aliquot.

11.8.3.2 Spike 1.0 mL of the native standard spiking solution (Section 7.11) into the OPR aliquot.

11.8.4 Extract the aliquots using the procedures in Section 12.4.

12.0 Extraction and concentration

- 12.1** Extraction procedures include solid phase (Section 12.2.1), separatory funnel (Section 12.2.2), and continuous liquid/liquid (Section 12.2.3) for aqueous liquids; Soxhlet/Dean-Stark (Section 12.3) for solids and filters; and Soxhlet extraction (Section 12.4) for tissues. Acid/base back-extraction (Section 12.5) is used for initial cleanup of extracts.

Macro-concentration procedures include rotary evaporation (Section 12.6.1), heating mantle (Section 12.6.2), and Kuderna-Danish (K-D) evaporation (Section 12.6.3). Micro-concentration uses nitrogen evaporation (Section 12.7).

12.2 Extraction of aqueous liquids

12.2.1 SPE of samples containing less than one percent solids

12.2.1.1 Disk preparation

12.2.1.1.1 Remove the test tube from the suction flask (Figure 4). Place an SPE disk on the base of the filter holder and wet with methylene chloride. While holding a GMF 150 filter above the SPE disk with tweezers, wet the filter with methylene chloride and lay the filter on the SPE disk, making sure that air is not trapped between the filter and disk. Clamp the filter and SPE disk between the 1-L glass reservoir and the vacuum filtration flask.

12.2.1.1.2 Rinse the sides of the reservoir with approx 15 mL of methylene chloride using a squeeze bottle or pipet. Apply vacuum momentarily until a few drops appear at the drip tip. Release the vacuum and allow the filter/disk to soak for approx one minute. Apply vacuum and draw all of the methylene chloride through the filter/disk. Repeat the wash step with approx 15 mL of acetone and allow the filter/disk to air dry.

12.2.1.2 Sample extraction

12.2.1.2.1 Pre-wet the disk by adding approx 20 mL of methanol to the reservoir. Pull most of the methanol through the filter/disk, retaining a layer of methanol approx 2 mm thick on the filter. Do not allow the filter/disk to go dry until the extraction is completed.

12.2.1.2.2 Add approx 20 mL of reagent water to the reservoir and pull most through, leaving a layer approx 2 mm thick on the filter/disk.

12.2.1.2.3 Allow the sample (Section 11.4.2.5) to stand for 1-2 hours, if necessary, to settle the suspended particles. Decant the clear layer of the sample, the blank (Section 11.4.2.4), or IPR/OPR aliquot (Section 11.4.2.4) into its respective reservoir and turn on the vacuum to begin the extraction. Adjust the vacuum to complete the extraction in no less than 10 minutes. For samples containing a high concentration of particles (suspended solids), the extraction time may be an hour or longer.

- 12.2.1.2.4** Before all of the sample has been pulled through the filter/disk, add approximately 50 mL of reagent water to the sample bottle, swirl to suspend the solids (if present), and pour into the reservoir. Pull through the filter/disk. Use additional reagent water rinses until all solids are removed.
- 12.2.1.2.5** Before all of the sample and rinses have been pulled through the filter/disk, rinse the sides of the reservoir with small portions of reagent water.
- 12.2.1.2.6** Partially dry the filter/disk under vacuum for approximately 3 minutes.
- 12.2.1.3** Elution of the filter/disk
- 12.2.1.3.1** Release the vacuum, remove the entire filter/disk/reservoir assembly from the vacuum flask, and empty the flask. Insert a test tube for eluant collection into the flask. The test tube should have sufficient capacity to contain the total volume of the elution solvent (approximately 50 mL) and should fit around the drip tip. The drip tip should protrude into the test tube to preclude loss of sample from spattering when vacuum is applied. Reassemble the filter/disk/reservoir assembly on the vacuum flask.
- 12.2.1.3.2** Wet the filter/disk with 4-5 mL of acetone. Allow the acetone to spread evenly across the disk and soak for 15-20 seconds. Pull the acetone through the disk, releasing the vacuum when approximately 1 mm thickness remains on the filter.
- 12.2.1.3.3** Rinse the sample bottle with approximately 20 mL of methylene chloride and transfer to the reservoir. Pull approximately half of the solvent through the filter/disk and release the vacuum. Allow the filter/disk to soak for approximately 1 minute. Pull all of the solvent through the disk. Repeat the bottle rinsing and elution step with another 20 mL of methylene chloride. Pull all of the solvent through the disk.
- 12.2.1.3.4** Release the vacuum, remove the filter/disk/reservoir assembly, and remove the test tube containing the sample solution. Quantitatively transfer the solution to a 250-mL separatory funnel and proceed to Section 12.5 for back-extraction.

12.2.2 Separatory funnel extraction

- 12.2.2.1** Pour the spiked sample (Section 11.4.2.2) into a 2-L separatory funnel. Rinse the bottle or flask twice with 5 mL of reagent water and add these rinses to the separatory funnel.
- 12.2.2.2** Add 60 mL methylene chloride to the empty sample bottle. Seal the bottle and shake 60 seconds to rinse the inner surface. Transfer the solvent to the separatory funnel, and extract the sample by shaking the funnel for 2 minutes with periodic venting. Allow the organic layer to separate from the aqueous phase for a minimum of 10 minutes. If an emulsion forms and is more than one-third the volume of the solvent layer, employ mechanical techniques to complete the phase separation (see note below). Drain the methylene chloride extract through a solvent-rinsed glass funnel approximately one-half full of granular anhydrous

sodium sulfate (Section 7.2.1) supported on clean glass-fiber paper into a solvent-rinsed concentration device (Section 12.6).

Note: If an emulsion forms, the laboratory must employ mechanical techniques to complete the phase separation. The optimum technique depends upon the sample, but may include stirring, filtration through glass wool, use of phase separation paper, centrifugation, use of an ultrasonic bath with ice, addition of NaCl, or other physical methods. Alternatively, solid-phase (Section 12.2.1), continuous liquid/liquid (CLLE; Section 12.2.3), or other extraction techniques may be used to prevent emulsion formation. Any alternative technique is acceptable so long as the requirements in Section 9.2 are met.

12.2.2.3 Extract the water sample two more times with 60-mL portions of methylene chloride. Drain each portion through the sodium sulfate into the concentrator. After the third extraction, rinse the separatory funnel with at least 20 mL of methylene chloride, and drain this rinse through the sodium sulfate into the concentrator. Repeat this rinse at least twice. Set aside the funnel with sodium sulfate if the extract is to be combined with the extract from the particles.

12.2.2.4 Concentrate the extract using one of the macro-concentration procedures in Section 12.6 and proceed to back extraction in Section 12.5.

12.2.3 Continuous liquid/liquid extraction

12.2.3.1 Place 100-150 mL methylene chloride in each continuous extractor and 200-300 mL in each distilling flask.

12.2.3.2 Pour the sample(s), blank, and QC aliquots into the extractors. Rinse the sample containers with 50-100 mL methylene chloride and add to the respective extractors. Include all solids in the extraction process.

12.2.3.3 Begin the extraction by heating the flask until the methylene chloride is boiling. When properly adjusted, 1-2 drops of methylene chloride per second will fall from the condenser tip into the water. Test and adjust the pH after 1-2 hours. Extract for 16-24 hours.

12.2.3.4 Remove the distilling flask, estimate and record the volume of extract (to the nearest 100 mL), and pour the contents through a drying column containing 7 to 10 cm of granular anhydrous sodium sulfate into a 500-mL K-D evaporator flask equipped with a 10-mL concentrator tube. Rinse the distilling flask with 30-50 mL of methylene chloride and pour through the drying column. Concentrate and exchange to hexane per Section 12.6 and back extract per Section 12.5.

12.3 SDS extraction of samples containing particles

12.3.1 Charge a clean extraction thimble (Section 6.4.2.2) with 5.0 g of 100/200 mesh silica (Section 7.5.1.1) topped with 100 g of quartz sand (Section 7.3.2). Do not disturb the silica layer throughout the extraction process.

12.3.2 Place the thimble in a clean extractor. Place 30 to 40 mL of toluene in the receiver and 200 to 250 mL of toluene in the flask.

- 12.3.3** Pre-extract the glassware by heating the flask until the toluene is boiling. When properly adjusted, 1 to 2 drops of toluene will fall per second from the condenser tip into the receiver. Extract the apparatus for a minimum of 3 hours.
- 12.3.4** After pre-extraction, cool and disassemble the apparatus. Rinse the thimble with toluene and allow to air dry.
- 12.3.5** Load the wet sample and/or filter from Sections 11.5.8, 11.6.5, or 11.7.5 and any non-aqueous liquid from Section 11.6.3 into the thimble and manually mix into the sand layer with a clean metal spatula, carefully breaking up any large lumps of sample.
- 12.3.6** Reassemble the pre-extracted SDS apparatus, and add a fresh charge of toluene to the receiver and reflux flask. Apply power to the heating mantle to begin refluxing. Adjust the reflux rate to match the rate of percolation through the sand and silica beds until water removal lessens the restriction to toluene flow. Frequently check the apparatus for foaming during the first 2 hours of extraction. If foaming occurs, reduce the reflux rate until foaming subsides.
- 12.3.7** Drain the water from the receiver at 1-2 hours and 8-9 hours, or sooner if the receiver fills with water. Save the water. Reflux the sample for a total of 16-24 hours.
- 12.3.8** Cool and disassemble the apparatus. Remove the distilling flask. Drain the water from the Dean-Stark receiver and add any toluene in the receiver to the extract in the flask. Record the total volume of water collected.
- 12.3.9** Quantitatively transfer the extract to a macro-concentration device (Section 12.6), and concentrate to near dryness. Dilute to approximately 100 mL with methylene chloride, quantitatively transfer to a 250-mL separatory funnel, and proceed with back-extraction (Section 12.5).

12.4 Soxhlet extraction of tissue

Note: This procedure includes determination of the lipid content of the sample (Sections 12.4.8 - 12.4.9), using the same sample extract that is analyzed by GC/MS. Alternatively, a separate sample aliquot may be used for the lipid determination. If a separate aliquot is used, use nitrogen to evaporate the main portion of the sample extract only to the extent necessary to effect the solvent exchange to n-hexane, so that loss of low molecular weight CBs is avoided, i.e., it is not necessary to dry the main portion of the sample to constant weight (Section 12.4.8).

- 12.4.1** Add 30 to 40 g of powdered anhydrous sodium sulfate (Section 7.2.2) to each of the beakers (Section 11.8.4) and mix thoroughly. Cover the beakers with aluminum foil and allow to equilibrate until the mixture becomes a free-flowing powder (30 minutes minimum). Remix prior to extraction to prevent clumping.
- 12.4.2** Assemble and pre-extract the Soxhlet apparatus per Sections 12.3.1-12.3.4, substituting methylene chloride for the pre-extraction and rinsing, and omitting the quartz sand.
- 12.4.3** Reassemble the pre-extracted Soxhlet apparatus and add a fresh charge of methylene chloride to the reflux flask.

- 12.4.4** Transfer the sample/sodium sulfate mixture (Section 12.4.1) to the Soxhlet thimble, and install the thimble in the Soxhlet apparatus.
- 12.4.5** Rinse the beaker with several portions of solvent mixture and add to the thimble. Fill the thimble/receiver with solvent. Extract for 18-24 hours.
- 12.4.6** After extraction, cool and disassemble the apparatus.
- 12.4.7** Quantitatively transfer the extract to a macro-concentration device (Section 12.6), and concentrate to near dryness. Set aside the concentration apparatus for re-use.
- 12.4.8** Complete the removal of the solvent using the nitrogen evaporation procedure (Section 12.7) and a water bath temperature of 60 °C. Weigh the receiver, record the weight, and return the receiver to the evaporation apparatus, concentrating the residue until a constant weight is obtained.

12.4.9 Percent lipid determination

- 12.4.9.1** Redissolve the residue in the receiver in hexane and spike 1.0 mL of the labeled cleanup standard spiking solution (Section 7.13) into the solution.
- 12.4.9.2** Transfer the residue/hexane to the anthropogenic isolation column (Section 13.5), retaining the boiling chips in the concentration apparatus. Use several rinses to assure that all material is transferred. If necessary, sonicate or heat the receiver slightly to assure that all material is re-dissolved. Allow the receiver to dry. Weigh the receiver and boiling chips.
- 12.4.9.3** Calculate the lipid content to the nearest three significant figures as follows:
- $$\% \text{ lipid} = 100 \times \text{weight of residue (g)} / \text{weight of tissue (g)}$$
- 12.4.9.4** The laboratory should determine the lipid content of the blank, IPR, and OPR to assure that the extraction system is working effectively.

12.5 Back-extraction with base and acid

- 12.5.1** Back-extraction may not be necessary for some samples. For some samples, the presence of color in the extract may indicate that back-extraction is necessary. If back-extraction is not performed, spike 1.0 mL of the labeled cleanup standard spiking solution (Section 7.13) into the extract and concentrate the extract for cleanup or analysis (Section 12.7). If back-extraction is necessary, spike 1.0 mL of the labeled cleanup standard spiking solution (Section 7.13) into the separatory funnels containing the sample and QC extracts from Section 12.2.3.4 or 12.3.9.
- 12.5.2** Partition the extract against 50 mL of potassium hydroxide solution (Section 7.1.1). Shake for 2 minutes with periodic venting into a hood. Remove and discard the aqueous layer. Repeat the base washing until no color is visible in the aqueous layer, to a maximum of four washings. Minimize contact time between the extract and the base to prevent degradation of the BDEs. Stronger potassium hydroxide solutions may be employed for back-extraction, provided that the laboratory meets the specifications for

labeled compound recovery and demonstrates acceptable performance using the procedure in Section 9.2.

- 12.5.3** Partition the extract against 50 mL of sodium chloride solution (Section 7.1.4) in the same way as with base. Discard the aqueous layer.
- 12.5.4** Partition the extract against 50 mL of sulfuric acid (Section 7.1.2) in the same way as with base. Repeat the acid washing until no color is visible in the aqueous layer, to a maximum of four washings.
- 12.5.5** Repeat the partitioning against sodium chloride solution and discard the aqueous layer.
- 12.5.6** Pour each extract through a drying column containing 7 to 10 cm of granular anhydrous sodium sulfate (Section 7.2.1). Rinse the separatory funnel with 30 to 50 mL of solvent, and pour through the drying column. Collect each extract in a round-bottom flask. Re-concentrate the sample and QC aliquots per Sections 12.6-12.7, and clean up the samples and QC aliquots per Section 13.
- 12.6** Macro-concentration—Extracts in toluene are concentrated using a rotary evaporator or a heating mantle; extracts in methylene chloride or hexane are concentrated using a rotary evaporator, heating mantle, or Kuderna-Danish apparatus.

Note: In the concentration procedures below, the extract must not be allowed to concentrate to dryness because the mono- through di- BDEs may be totally or partially lost.

- 12.6.1** Rotary evaporation—Concentrate the extracts in separate round-bottom flasks.
- 12.6.1.1** Assemble the rotary evaporator according to manufacturer's instructions, and warm the water bath to 45 °C. On a daily basis, pre-clean the rotary evaporator by concentrating 100 mL of clean extraction solvent through the system. Archive both the concentrated solvent and the solvent in the catch flask for a contamination check if necessary. Between samples, rinse three 2- to 3-mL aliquots of solvent down the feed tube into a waste beaker to preclude sample cross-contamination.
- 12.6.1.2** Attach the round-bottom flask containing the sample extract to the rotary evaporator. Slowly apply vacuum to the system, and begin rotating the sample flask.
- 12.6.1.3** Lower the flask into the water bath, and adjust the speed of rotation and the temperature as required to complete concentration in 15 to 20 minutes. At the proper rate of concentration, the flow of solvent into the receiving flask will be steady, but no bumping or visible boiling of the extract will occur.

Note: If the rate of concentration is too fast, analyte loss may occur.

- 12.6.1.4** When the liquid in the concentration flask has reached an apparent volume of approximately 2 mL, remove the flask from the water bath and stop the rotation. Slowly and carefully admit air into the system. Be sure not to open the valve so quickly that the sample is blown out of the flask. Rinse the feed tube with approximately 2 mL of solvent.

- 12.6.1.5** Proceed to Section 12.6.4 for preparation for back-extraction or micro-concentration and solvent exchange.
- 12.6.2** Heating mantle—Concentrate the extracts in separate round-bottom flasks.
- 12.6.2.1** Add one or two clean boiling chips to the round-bottom flask, and attach a three-ball macro Snyder column. Prewet the column by adding approximately 1 mL of solvent through the top. Place the round-bottom flask in a heating mantle, and apply heat as required to complete the concentration in 15 to 20 minutes. At the proper rate of distillation, the balls of the column will actively chatter, but the chambers will not flood.
- 12.6.2.2** When the liquid has reached an apparent volume of approximately 10 mL, remove the round-bottom flask from the heating mantle and allow the solvent to drain and cool for at least 10 minutes. Remove the Snyder column and rinse the glass joint into the receiver with small portions of solvent.
- 12.6.2.3** Proceed to Section 12.6.4 for preparation for back-extraction or micro-concentration and solvent exchange.
- 12.6.3** Kuderna-Danish (K-D)—Concentrate the extracts in separate 500-mL K-D flasks equipped with 10-mL concentrator tubes. The K-D technique is used for solvents such as methylene chloride and hexane. Toluene is difficult to concentrate using the K-D technique unless a water bath fed by a steam generator is used.
- 12.6.3.1** Add 1 to 2 clean boiling chips to the receiver. Attach a three-ball macro Snyder column. Prewet the column by adding approximately 1 mL of solvent through the top. Place the K-D apparatus in a hot water bath so that the entire lower rounded surface of the flask is bathed with steam.
- 12.6.3.2** Adjust the vertical position of the apparatus and the water temperature as required to complete the concentration in 15 to 20 minutes. At the proper rate of distillation, the balls of the column will actively chatter but the chambers will not flood.
- 12.6.3.3** When the liquid has reached an apparent volume of 1 mL, remove the K-D apparatus from the bath and allow the solvent to drain and cool for at least 10 minutes. Remove the Snyder column and rinse the flask and its lower joint into the concentrator tube with 1 to 2 mL of solvent. A 5-mL syringe is recommended for this operation.
- 12.6.3.4** Remove the three-ball Snyder column, add a fresh boiling chip, and attach a two ball micro Snyder column to the concentrator tube. Prewet the column by adding approximately 0.5 mL of solvent through the top. Place the apparatus in the hot water bath.
- 12.6.3.5** Adjust the vertical position and the water temperature as required to complete the concentration in 5 to 10 minutes. At the proper rate of distillation, the balls of the column will actively chatter but the chambers will not flood.

- 12.6.3.6** When the liquid reaches an apparent volume of 0.5 mL, remove the apparatus from the water bath and allow to drain and cool for at least 10 minutes.
- 12.6.3.7** Proceed to 12.6.4 for preparation for back-extraction or micro-concentration and solvent exchange.

12.6.4 Preparation for back-extraction or micro-concentration and solvent exchange

- 12.6.4.1** For back-extraction (Section 12.5), transfer the extract to a 250-mL separatory funnel. Rinse the concentration vessel with small portions of hexane, adjust the hexane volume in the separatory funnel to 10 to 20 mL, and proceed to back-extraction (Section 12.5).
- 12.6.4.2** For determination of the weight of residue in the extract, or for clean-up procedures other than back-extraction, transfer the extract to a evaporation vial using 2-3 rinses of solvent. Proceed with micro-concentration and solvent exchange (Section 12.7).

12.7 Micro-concentration and solvent exchange

- 12.7.1** Extracts to be subjected to GPC cleanup are exchanged into methylene chloride. Extracts to be cleaned up using silica gel, Florisil, and/or alumina are exchanged into hexane.
- 12.7.2** Transfer the vial containing the sample extract to a nitrogen evaporation device. Adjust the flow of nitrogen so that the surface of the solvent is just visibly disturbed. A large vortex in the solvent may cause analyte loss.
- 12.7.3** Lower the vial into a 45 °C water bath and continue concentrating.
 - 12.7.3.1** If the extract or an aliquot of the extract is to be concentrated to dryness for weight determination (Sections 12.4.8 -12.4.9 and 13.5.4), blow dry until a constant weight is obtained.
 - 12.7.3.2** If the extract is to be concentrated for injection into the GC/MS or the solvent is to be exchanged for extract cleanup, proceed as follows:
- 12.7.4** When the volume of the liquid is approximately 100 µL, add 2 to 3 mL of the desired solvent (methylene chloride for GPC or hexane for the other cleanups) and continue concentrating to approximately 100 µL. Repeat the addition of solvent and concentrate once more.
- 12.7.5** If the extract is to be cleaned up by GPC, adjust the volume of the extract to 5.0 mL with methylene chloride and proceed with GPC cleanup (Section 13.2).
- 12.7.6** If the extract is to be cleaned up by column chromatography (silica gel, Florisil, or alumina), bring the final volume to 1.0 mL with hexane. Proceed with column cleanup (Sections 13.3, 13.4, or 13.6).
- 12.7.7** If the extract is to be concentrated for injection into the GC/MS (Section 14), quantitatively transfer the extract to a 0.3-mL conical vial for final concentration, rinsing the larger vial with hexane and adding the rinse to the conical vial. Reduce the volume to

approximately 100 μL . Add 20 μL of nonane to the vial, and evaporate the solvent to the level of the nonane. Seal the vial and label with the sample number. Store in the dark at room temperature until ready for GC/MS analysis. If GC/MS analysis will not be performed on the same day, store the vial at less than $-10\text{ }^{\circ}\text{C}$.

13.0 Extract cleanup

13.1 Cleanup may not be necessary for relatively clean samples (e.g., treated effluents, groundwater, drinking water). If particular circumstances require the use of a cleanup procedure, the laboratory may use any or all of the procedures below or any other appropriate procedure. Before using a cleanup procedure, the laboratory must demonstrate that the requirements of Section 9.2 can be met using the cleanup procedure.

13.1.1 Gel permeation chromatography (Section 13.2) removes high molecular weight interferences that cause GC column performance to degrade. It should be used for all soil and sediment extracts. It may be used for water extracts that are expected to contain high molecular weight organic compounds (e.g., polymeric materials, humic acids). It should also be used for tissue extracts after initial cleanup on the anthropogenic isolation column (Section 13.5).

13.1.2 Acid, neutral, and basic silica gel (Section 13.3), alumina (Section 13.4), and Florisil (Section 13.6) are used to remove non-polar and polar interferences.

13.1.3 The anthropogenic isolation column (Section 13.5) is used for removal of lipids from tissue samples.

13.2 Gel permeation chromatography (GPC)

13.2.1 Column packing

13.2.1.1 Place 70 to 75 g of SX-3 Bio-beads (Section 6.7.1.1) in a 400- to 500-mL beaker.

13.2.1.2 Cover the beads with methylene chloride and allow to swell overnight (a minimum of 12 hours).

13.2.1.3 Transfer the swelled beads to the column (Section 6.7.1.1) and pump solvent through the column, from bottom to top, at 4.5 to 5.5 mL/minute prior to connecting the column to the detector.

13.2.1.4 After purging the column with solvent for 1 to 2 hours, adjust the column head pressure to 7 to 10 psig and purge for 4 to 5 hours to remove air. Maintain a head pressure of 7 to 10 psig. Connect the column to the detector (Section 6.7.1.4).

13.2.2 Column calibration

13.2.2.1 Load 5 mL of the GPC calibration solution (Section 7.4) into the sample loop.

- 13.2.2.2** Inject the GPC calibration solution and record the signal from the detector. The elution pattern will be corn oil, DeBDE, BEHP, methoxychlor, perylene, and sulfur.
 - 13.2.2.3** Set the "dump time" to allow >85% removal the corn oil and >85% collection of DeBDE (see the note in Section 7.4).
 - 13.2.2.4** Set the "collect time" to the time of the sulfur peak maximum.
 - 13.2.2.5** Verify calibration with the GPC calibration solution after every 20 extracts. Calibration is verified if the recovery of the DeBDE is greater than 85%. If calibration is not verified, the system must be recalibrated using the GPC calibration solution, and the previous sample batch must be re-extracted and cleaned up using the calibrated GPC system.
- 13.2.3** Extract cleanup—GPC requires that the column not be overloaded. The column specified in this Method is designed to handle a maximum of 0.5 g of material from an aqueous, soil, or mixed-phase sample in a 5-mL extract, and has been shown to handle 1.5 g of lipid from a tissue sample in a 5-mL extract. If the extract is known or expected to contain more than these amounts, the extract is split into aliquots for GPC, and the aliquots are combined after elution from the column. The residue content of the extract may be obtained gravimetrically by evaporating the solvent from a 50- μ L aliquot.
- 13.2.3.1** Filter the extract or load through the filter holder (Section 6.7.1.3) to remove particles. Load the 5.0-mL extract onto the column.
 - 13.2.3.2** Elute the extract using the calibration data determined in Section 13.2.2. Collect the eluate in a clean 400- to 500-mL beaker. Allow the system to rinse for additional 10 minutes before injecting the next sample.
 - 13.2.3.3** Rinse the sample loading tube thoroughly with methylene chloride between extracts to prepare for the next sample.
 - 13.2.3.4** If an extract is encountered that could overload the GPC column to the extent that carry-over could occur, a 5.0-mL methylene chloride blank must be run through the system to check for carry-over.
 - 13.2.3.5** Concentrate the eluate per Sections 12.6 and 12.7 for further cleanup or injection into the GC/MS.

13.3 Silica gel cleanup

- 13.3.1** Place a glass-wool plug in a 15-mm ID chromatography column (Section 6.7.3.2). Pack the column bottom to top with: 1 g silica gel (Section 7.5.1.1), 4 g basic silica gel (Section 7.5.1.3), 1 g silica gel, 8 g acid silica gel (Section 7.5.1.2), 2 g silica gel, and 4 g granular anhydrous sodium sulfate (Section 7.2.1). Tap the column to settle the adsorbents.
- 13.3.2** Pre-elute the column with 50 to 100 mL of hexane. Close the stopcock when the hexane is within 1 mm of the sodium sulfate. Discard the eluate. Check the column for channeling. If channeling is present, discard the column and prepare another.

- 13.3.3** Apply the concentrated extract to the column. Open the stopcock until the extract is within 1 mm of the sodium sulfate.
- 13.3.4** Rinse the receiver twice with 1-mL portions of hexane, and apply separately to the column. Elute the BDEs with 25 mL of n-hexane and collect the eluate.
- 13.3.5** Concentrate the eluate per Section 12.6 and 12.7 for further cleanup or injection into the GC/MS.
- 13.3.6** For extracts of samples known to contain large quantities of other organic compounds, it may be advisable to increase the capacity of the silica gel column. This may be accomplished by increasing the strengths of the acid and basic silica gels. The acid silica gel (Section 7.5.1.2) may be increased in strength to as much as 40% w/w (6.7 g sulfuric acid added to 10 g silica gel). The basic silica gel (Section 7.5.1.3) may be increased in strength to as much as 33% w/w (50 mL 1N NaOH added to 100 g silica gel), or the potassium silicate (Section 7.5.1.4) may be used.

The use of stronger acid silica gel (44% w/w) may lead to charring of organic compounds in some extracts. The charred material may retain some of the analytes and lead to lower recoveries of the BDEs. Increasing the strengths of the acid and basic silica gel may also require different volumes of solvent than those specified above to elute the analytes from the column. The performance of the Method after such modifications must be verified by the procedure in Section 9.2.

13.4 Alumina

- 13.4.1** Place a glass-wool plug in a 15-mm ID chromatography column (Section 6.7.3.2).
- 13.4.2** If using acid alumina, pack the column by adding 6 g acid alumina (Section 7.5.2.1); if using basic alumina, substitute 6 g basic alumina (Section 7.5.2.2). Tap the column to settle the adsorbent.
- 13.4.3** Pre-elute the column with 50 to 100 mL of hexane. Close the stopcock when the hexane is within 1 mm of the alumina.
- 13.4.4** Discard the eluate. Check the column for channeling. If channeling is present, discard the column and prepare another.
- 13.4.5** Apply the concentrated extract to the column. Open the stopcock until the extract is within 1 mm of the alumina.
- 13.4.6** Rinse the receiver twice with 1-mL portions of hexane and apply separately to the column. Elute the interfering compounds with 15 mL hexane and discard the eluate.
- 13.4.7** The volume of eluting solvents will depend on the choice (acid or basic) and activity of the alumina. Determine the volume by test.
- 13.4.8** Elute interferences with n-hexane and discard the elute. Elute the BDEs with methylene chloride:hexane (50:50 v/v) and collect the eluate.

- 13.4.9** Concentrate the eluate per Section 12.6 and 12.7 for further cleanup or injection into the GC/MS.
- 13.5** Anthropogenic isolation column (Reference 15)—Used for removal of lipids from tissue extracts.
- 13.5.1** Prepare the column as given in Section 7.5.3.
- 13.5.2** Pre-elute the column with 100 mL of hexane. Drain the hexane layer to the top of the column, but do not expose the sodium sulfate.
- 13.5.3** Load the sample and rinses (Section 12.4.9.2) onto the column by draining each portion to the top of the bed. Elute the BDEs from the column into the apparatus used for concentration (Section 12.4.7) using 200 mL of hexane.
- 13.5.4** Remove a small portion (e.g, 50 μ L) of the extract for determination of residue content. Estimate the percent of the total that this portion represents. Concentrate the small portion to constant weight per Section 12.7.3.1. Calculate the total amount of residue in the extract. If more than 500 mg of material remains, repeat the cleanup using a fresh anthropogenic isolation column.
- 13.5.5** If necessary, exchange the extract to a solvent suitable for the additional cleanups to be used (Section 13.2-13.4 and 13.6).
- 13.5.6** Clean up the extract using the procedures in Sections 13.2-13.4 and 13.6. GPC (Section 13.2) and Florisil (Section 13.6) are recommended as minimum additional cleanup steps.
- 13.5.7** Following cleanup, concentrate the extract to 20 μ L as described in Section 12.7 and proceed with the analysis in Section 14.
- 13.6** Florisil cleanup (Reference 16)
- 13.6.1** Begin to drain the n-hexane from the column (Section 7.5.4.1.2). Adjust the flow rate of eluant to 4.5-5.0 mL/min.
- 13.6.2** When the n-hexane is within 1 mm of the sodium sulfate, apply the sample extract (in hexane) to the column. Rinse the sample container twice with 1-mL portions of hexane and apply to the column.
- 13.6.3** Elute the BDEs with n-hexane and/or ether in n-hexane and collect the eluate. The exact volumes of solvents will need to be determined for each batch of Florisil. If the BDEs are not to be separated according to polarity, elute all BDEs with ether in n-hexane.
- 13.6.4** Concentrate the eluate(s) per Sections 12.6-12.7 for further cleanup or for injection into the GC/MS.

14.0 HRGC/HRMS analysis

- 14.1 Establish the operating conditions given in Section 10.1.
- 14.2 Add 2 μL of the labeled injection internal standard spiking solution (Section 7.14) to the 20 μL sample extract immediately prior to injection to minimize the possibility of loss by evaporation, adsorption, or reaction. If an extract is to be reanalyzed and evaporation has occurred, do not add more labeled injection internal standard spiking solution. Rather, bring the extract back to its previous volume with nonane (e.g., 19 μL if a 1- μL injection is used; 18 μL if a 2- μL injection is used).
- 14.3 Inject 1.0 or 2.0 μL of the concentrated extract containing the labeled injection internal standards using on-column or splitless injection. The volume injected must be identical to the volume used for calibration (Section 10.3).
 - 14.3.1 Start the GC column initial isothermal hold upon injection. Start MS data collection after the solvent peak elutes.
 - 14.3.2 Monitor the exact m/zs at each LOB throughout the LOB retention time window. Where warranted, monitor m/zs associated with congeners at higher levels of bromination to assure that fragments are not interfering with the m/zs for congeners at lower levels of bromination. Also where warranted, monitor m/zs associated with interferants expected to be present.
 - 14.3.3 Stop data collection after $^{13}\text{C}_{12}$ -DeBDE has eluted. Return the column to the initial temperature for analysis of the next extract or standard.

15.0 System and laboratory performance

- 15.1 At the beginning of each 12-hour shift during which analyses are performed, GC/MS system performance and calibration are verified for all native BDEs and labeled compounds. For these tests, the CS-3 calibration verification (VER) standard (Section 7.10.1 and Table 5) is analyzed. If BDEs in addition to the BDEs of primary interest are to be determined, the Diluted combined congener solution (Section 7.10.2.2) is used in place of the VER standard to verify all performance criteria. Adjustment and/or recalibration (Section 10) must be performed until all performance criteria are met. Only after all performance criteria are met may samples, blanks, IPRs, and OPRs be analyzed.
- 15.2 MS resolution—Static resolving power checks must be performed at the beginning and at the end of each shift per Sections 10.2.1. If analyses are performed on successive shifts, only the beginning of shift static resolving power check is required. If the requirement in Section 10.2.1 cannot be met, the problem must be corrected before analyses can proceed. If any of the samples in the previous shift may be affected by poor resolution, those samples must be re-analyzed.

15.3 Calibration verification

- 15.3.1** Inject the VER (CS-3) standard using the procedure in Section 14. If BDEs in addition to the BDEs of primary interest are to be determined, inject the diluted combined congener solution (7.10.2.2).
- 15.3.2** The ion abundance ratios for all BDEs must be within the limits in Table 8; otherwise, the mass spectrometer must be adjusted until the m/z abundance ratios fall within the limits specified when the verification test is repeated. If the adjustment alters the resolution of the mass spectrometer, resolution must be verified (Section 10.2.1) prior to repeat of the verification test.
- 15.3.3** The GC peak representing each native BDE and labeled compound in the VER standard must be present with a S/N of at least 10; otherwise, the mass spectrometer must be adjusted and the verification test repeated.
- 15.3.4** Compute the concentration of the BDEs that have a labeled analog by isotope dilution (Section 17.1). These concentrations are computed based on the calibration data in Section 10.
- 15.3.5** For each compound, compare the concentration with the calibration verification limit in Table 6. If all compounds meet the acceptance criteria, calibration has been verified and analysis of standards and sample extracts may proceed. If, however, any compound fails its respective limit, the measurement system is not performing properly. In this event, prepare a fresh calibration standard or correct the problem and repeat the resolution (Section 15.2) and verification (Section 15.3) tests, or recalibrate (Section 10). If recalibration is required, recalibration for all congeners (Section 10.5) must also be performed.

15.4 GC performance

15.4.1 Retention times

- 15.4.1.1** Absolute—The absolute retention times for the congeners in the labeled standard (Section 7.12) in the verification test (Section 15.3) must be within ± 15 seconds of the respective retention times in the calibration.
- 15.4.1.2** Relative—The relative retention times of native BDEs and labeled compounds in the verification test (Section 15.3) must be within their respective RRT limits in Table 2 (Section 6.9.1.1) or, if an alternate column or column system is employed, within their respective RRT limits for the alternate column or column system (Section 6.9.1.3).
- 15.4.1.3** If the absolute or relative retention time of any compound is not within the limits specified, the GC is not performing properly. In this event, adjust the GC and repeat the verification test (Section 15.3) or recalibrate (Section 10), or replace the GC column and either verify calibration or recalibrate.

15.4.2 GC minimum analysis time and peak tailing

15.4.2.1 The peak tailing, resolution, and minimum analysis time specifications in Sections 6.9.1.1.2 - 6.9.1.1.4 must be met for the DB-5HT column or, if an alternate column or column system is employed, must be met as specified for the alternate column or column system (Section 6.9.1.2.1 - 6.9.1.2.3). If these specifications are not met, the GC analysis conditions must be adjusted until the specifications are met, or the column must be replaced and the calibration verification tests repeated (Sections 15.4.1 through 15.4.2), or the system must be recalibrated (Section 10).

15.4.2.2 After the peak tailing and minimum analysis time specifications are met, update the retention times, relative retention times, and response factors for all congeners except the response factors for the compounds that are multi-point calibrated. For these compounds, the multi-point calibration data must be used (see Section 10.4 and 15.3).

15.4.3 When using either the TPI in section 6.9.2 or the short column in section 10.1.3 a DeBDE breakdown test should be performed - Analyze DeBDE by itself and if more than 10% total OcBDE + NoBDE are present, adjust chromatographic conditions to eliminate the breakdown.

15.5 Ongoing precision and recovery

15.5.1 Analyze the extract of the ongoing precision and recovery (OPR) aliquot (Section 11.4.2.4, 11.5.4, 11.6.2, or 11.8.3.2) prior to analysis of samples from the same batch.

15.5.2 Compute the percent recovery of the native compounds that have a labeled analog by isotope dilution (Section 10.4). Compute the percent recovery of each labeled compound by the internal standard method (Section 10.5).

15.5.3 For the native BDEs and labeled compounds, compare the recovery to the OPR limits given in Table 6. If all compounds meet the acceptance criteria, system performance is acceptable and analysis of blanks and samples may proceed. If, however, any individual concentration falls outside of the range given, the extraction/concentration processes are not being performed properly for that compound. In this event, correct the problem, re-prepare, extract, and clean up the sample batch and repeat the ongoing precision and recovery test (Section 15.5).

15.5.4 If desired, add results that pass the specifications in Section 15.5.3 to initial and previous ongoing data for each compound in each matrix. Update QC charts to form a graphic representation of continued laboratory performance. Develop a statement of laboratory accuracy for each congener in each matrix type by calculating the average percent recovery (R) and the standard deviation of percent recovery (S_R). Express the accuracy as a recovery interval from $R - 2S_R$ to $R + 2S_R$. For example, if $R = 95\%$ and $S_R = 5\%$, the accuracy is 85 to 105%.

15.6 Blank—Analyze the method blank extracted with each sample batch immediately following analysis of the OPR aliquot to demonstrate freedom from contamination and freedom from carryover from the OPR analysis. The results of the analysis of the blank must meet the specifications in Section 9.5.2 before sample analyses may proceed.

16.0 Qualitative determination

A BDE or labeled compound is identified in a standard, blank, or sample when all of the criteria in Sections 16.1 through 16.4 are met.

- 16.1 The signals for the two exact m/zs in Table 7 must be present and must maximize within the same two scans.
- 16.2 The signal-to-noise ratio (S/N) for the GC peak at each exact m/z must be greater than or equal to 2.5 for each BDE detected in a sample extract, and greater than or equal to 10 for all BDEs in the calibration and verification standards (Sections 10.3.3 and 15.3.3).
- 16.3 The ratio of the integrated areas of the two exact m/zs specified in Table 7 must be within the limit in Table 8, or within ± 15 percent of the ratio in the midpoint (CS-3) calibration or calibration verification (VER), whichever is most recent.
- 16.4 The relative retention time of the peak for a BDE must be within the RRT QC limits specified in Table 2 or developed from calibration data or, if an alternate column or column system is employed, within its respective RRT QC limits for the alternate column or column system (Section 6.9.1.1 - 6.9.1.3).

For native BDEs determined by internal standard quantitation, a given BDE congener may fall within more than RT window and be misidentified unless the RRT windows are made very narrow, as in Table 2. Therefore, consistency of the RT and RRT with other congeners and the labeled compounds may be required for rigorous congener identification. Retention time regression analysis may aid in this identification.

- 16.5 Because of congener overlap and the potential for interfering substances, it is possible that all of the identification criteria (Sections 16.1-16.4) may not be met. It is also possible that loss of one or more bromines from a highly brominated congener may inflate or produce a false concentration for a less-brominated congener that elutes at the same retention time. If identification is ambiguous, an experienced spectrometrist (Section 1.4) must determine the presence or absence of the congener.
- 16.6 If the criteria for identification in Sections 16.1-16.5 are not met, the congener has not been identified and the result for that congener may not be reported or used for permitting or regulatory compliance purposes. If interferences preclude identification, a new aliquot of sample must be extracted, further cleaned up, and analyzed.

17.0 Quantitative determination

17.1 Isotope dilution quantitation

- 17.1.1 By adding a known amount of the labeled compounds to every sample prior to extraction, correction for recovery of the BDE can be made because the native compound and its labeled analog exhibit similar effects upon extraction, concentration, and gas chromatography. Relative responses (RRs) are used in conjunction with the calibration data in Section 10.4 to determine concentrations in the final extract, so long as labeled compound spiking levels are constant.

- 17.1.2** Compute the concentrations in the extract of the BDEs that have a labeled analog using the RRs from the calibration data (Section 10.4) and following equation:

$$C_{ex} \text{ (ng/mL)} = (AI_n + A2_n) C_l / (AI_l + A2_l) RR$$

where:

C_{ex} = concentration of the BDE in the extract (ng/mL) and the other terms are as defined in Section 10.4.2

17.2 Internal standard quantitation and labeled compound recovery

- 17.2.1** Compute the concentrations in the extract of the BDEs other than those that have a labeled analog using the response factors determined from the calibration data (Section 10.5) and the following equation:

$$C_{ex} \text{ (ng/mL)} = (AI_s + A2_s) C_{is} / (AI_{is} + A2_{is}) RF$$

where:

C_{ex} = concentration of the BDE in the extract (ng/mL) and the other terms are as defined in Section 10.5.2

- 17.2.2** Using the concentration in the extract determined above, compute the percent recovery of the labeled standard BDEs and the labeled cleanup standard BDEs using the following equation:

$$\text{Recovery (\%)} = 100 \times \text{Concentration found (ng/mL)} / \text{Concentration spiked (ng/mL)}$$

- 17.3** The concentration of a native BDE in the solid phase of the sample is computed using the concentration of the compound in the extract and the weight of the solids (Section 11.2.2.3), as follows:

$$\text{Concentration in solid (ng/kg)} = 1000 (C_{ex} \times V_{ex}) / W_s$$

where:

C_{ex} = concentration of the BDE in the extract (ng/mL)

V_{ex} = extract volume (mL)

W_s = sample dry weight (g)

- 17.4** The concentration of a native BDE in the aqueous phase of the sample is computed using the concentration of the compound in the extract and the volume of water extracted (Section 11.4), as follows:

$$\text{Concentration in aqueous phase (pg/L)} = 1000 (C_{ex} \times V_{ex}) / V_s$$

where:

C_{ex} = concentration of the BDE in the extract (ng/mL)

V_{ex} = extract volume (mL)

V_s = sample volume (L)

- 17.5** If the SICP area at either quantitation m/z for any congener exceeds the calibration range of the system, dilute the sample extract by the factor necessary to bring the concentration within the calibration range, adjust the concentration of the labeled injection internal standard to 100 pg/ μ L in the extract, and analyze an aliquot of this diluted extract. If the BDEs cannot be measured reliably by isotope dilution, dilute and analyze an aqueous sample or analyze a smaller portion of a soil, tissue, or mixed-phase sample. Adjust the BDE congener concentrations, detection limits, and minimum levels to account for the dilution.
- 17.6** Reporting of results—Results are reported to three significant figures for the BDEs and labeled compounds found in all standards, blanks, and samples.

17.6.1 Reporting units and levels

17.6.1.1 Aqueous samples—Report results in pg/L (parts-per-quadrillion).

17.6.1.2 Samples containing greater than 1% solids (soils, sediments, filter cake, compost)—Report results in ng/kg based on the dry weight of the sample. Report the percent solids so that the result may be converted to aqueous units.

17.6.1.3 Tissues—Report results in ng/kg of wet tissue, not on the basis of the lipid content of the tissue. Report the percent lipid content, so that the data user can calculate the concentration on a lipid basis if desired.

17.6.1.4 Reporting level

17.6.1.4.1 Report results above the minimum level of quantitation (ML) for analyses of blanks, standards, and samples. The MLs in Table 2 are the levels that can be achieved in the presence of common laboratory contamination. A laboratory may establish an ML for a BDE lower than the MLs in Table 2. MLs may be established as low as the lowest calibration point (Table 5) provided that the concentration of the congener in a minimum of 10 blanks for a sample medium (e.g., water, soil, sludge, tissue) is significantly below the ML in Table 2. Significant means that the ML for the congener is no less than 2 standard deviations above the mean (average) level in the minimum of 10 blanks (Reference 17). The blanks must be analyzed during the same period that samples are analyzed, ideally over an approximately 1-month period.

17.6.1.4.2 Standards (VER, IPR, OPR) and samples—Report the result for each congener at or above the ML to 3 significant figures. Report results below the ML as <ML (where ML is the concentration at the ML) or as required by the regulatory authority or permit.

17.6.1.4.3 Blanks—Report results above the ML to 3 significant figures. Report results below the ML but above the MDL to 2 significant figures. Report results below the MDL as <MDL (where MDL is the concentration at the MDL) or as required by the regulatory authority or permit.

17.6.1.4.4 Blank correction—Blank-corrected results may be reported in addition to reporting of separate results for samples (Section 17.6.1.4.1) and blanks (Section 17.6.1.4.3). The recommended procedure for blank correction

(Reference 17) is that a result is significantly above the blank level, and the level in the blank may be subtracted, if the result is greater than 2 standard deviations above the mean (average) of results of analyses of 10 or more blanks for a sample medium.

- 17.6.2** Results for a BDE in a sample that has been diluted are reported at the least dilute level at which the area at the quantitation m/z is within the calibration range (Section 17.5).
- 17.6.3** For a BDE having a labeled analog, report results at the least dilute level at which the area at the quantitation m/z is within the calibration range (Section 17.5) and the labeled compound recovery is within the normal range for the Method (Section 9.3 and Table 6).
- 17.6.4** If requested, the total concentration of all congeners at a given level of bromination (homolog; i.e., total TrBDE, total PeBDE, total HxBDE, etc) may be reported by summing the concentrations of all congeners identified at that LOB, including the BDEs of primary interest and other BDEs. Also if requested, total BDE may be reported by summing all congeners identified at all LOBs.

18.0 Analysis of complex samples

- 18.1** Some samples may contain high levels (>10 ng/L; >1000 ng/kg) of the compounds of interest, interfering compounds, and/or polymeric materials. Some extracts may not concentrate to 20 μ L (Section 12.7); others may overload the GC column and/or mass spectrometer. Fragment ions from congeners at higher levels of bromination may interfere with determination of congeners at lower levels of bromination.
- 18.2** Analyze a smaller aliquot of the sample (Section 17.5) when the extract will not concentrate to 20 μ L after all cleanup procedures have been exhausted. If a smaller aliquot of soils or mixed-phase samples is analyzed, attempt to assure that the sample is representative.
- 18.3** Perform integration of peak areas and calculate concentrations manually when interferences preclude computerized calculations.
- 18.4** Several laboratories have reported that backgrounds of many of the BDE congeners are difficult to eliminate, and that these backgrounds can interfere with the determination of the BDEs in environmental samples. Backgrounds of the BDEs of primary interest (Section 1.1.1) are common. The effects of contamination on results for these congeners should be understood in order to make a reliable determination.
- 18.5** Recovery of labeled compounds—In most samples, recoveries of the labeled compounds will be similar to those from reagent water or from the alternate matrix (Section 7.6).
 - 18.5.1** If the recovery of any of the labeled compounds is outside of the normal range (Table 6), a diluted sample must be analyzed (Section 17.5).
 - 18.5.2** If the recovery of any of the labeled compounds in the diluted sample is outside of normal range, the calibration verification standard (Section 7.10.1 and Table 5) must be analyzed and calibration verified (Section 15.3).

18.5.3 If the calibration cannot be verified, a new calibration must be performed and the original sample extract reanalyzed.

18.5.4 If calibration is verified and the diluted sample does not meet the limits for labeled compound recovery, the Method does not apply to the sample being analyzed and the result may not be reported or used for permitting or regulatory compliance purposes. In this case, alternate extraction and cleanup procedures in this Method or an alternate GC column must be employed to resolve the interference. If all cleanup procedures in this Method and an alternate GC column have been employed and labeled compound recovery remains outside of the normal range, extraction and/or cleanup procedures that are beyond this scope of this Method will be required to analyze the sample.

19.0 Pollution prevention

19.1 Pollution prevention encompasses any technique that reduces or eliminates the quantity or toxicity of waste at the point of generation. Many opportunities for pollution prevention exist in laboratory operations. EPA has established a preferred hierarchy of environmental management techniques that places pollution prevention as the management option of first choice. Whenever feasible, laboratory personnel should use pollution prevention techniques to address waste generation. When wastes cannot be reduced feasibly at the source, the Agency recommends recycling as the next best option.

19.2 The BDEs in this Method are used in extremely small amounts and pose little threat to the environment when managed properly. Standards should be prepared in volumes consistent with laboratory use to minimize the disposal of excess volumes of expired standards.

19.3 For information about pollution prevention that may be applied to laboratories and research institutions, consult *Less is Better: Laboratory Chemical Management for Waste Reduction*, available from the American Chemical Society's Department of Governmental Relations and Science Policy, 1155 16th Street NW, Washington DC 20036, 202/872-4477.

20.0 Waste management

20.1 The laboratory is responsible for complying with all Federal, State, and local regulations governing waste management, particularly the hazardous waste identification rules and land disposal restrictions, and to protect the air, water, and land by minimizing and controlling all releases from fume hoods and bench operations. Compliance is also required with any sewage discharge permits and regulations. An overview of requirements can be found in *Environmental Management Guide for Small Laboratories* (EPA 233-B-98-001).

20.2 Samples containing HCl or H₂SO₄ to pH <2 are hazardous and must be neutralized before being poured down a drain or must be handled as hazardous waste.

20.3 The BDEs decompose above 800 °C. Low-level waste such as absorbent paper, tissues, animal remains, and plastic gloves may be burned in an appropriate incinerator. Gross quantities (milligrams) should be packaged securely and disposed of through commercial or governmental channels that are capable of handling extremely toxic wastes.

20.4 Liquid or soluble waste should be dissolved in methanol or ethanol and irradiated with ultraviolet light with a wavelength shorter than 290 nm for several days. Use F40 BL or equivalent lamps. Analyze liquid wastes, and dispose of the solutions when the BDEs can no longer be detected.

20.5 For further information on waste management, consult *The Waste Management Manual for Laboratory Personnel* and *Less is Better-Laboratory Chemical Management for Waste Reduction*, available from the American Chemical Society's Department of Government Relations and Science Policy, 1155 16th Street NW, Washington, DC 20036.

21.0 Method performance

Method 1614 was developed in a single laboratory (Reference 18). Figure 8 is a chromatogram showing method performance at each level of bromination.

22.0 References

1. Telliard, W.A. and D.R. Rushneck, 2002, Consensus obtained at the "4th Annual Workshop on Brominated Flame Retardants in the Environment," June 17-18, 2002, Canada Centre for Inland Waters, 867 Lakeshore Road, Burlington, Ontario, Canada
2. "Results of the Literature Search on Polybrominated Diphenyl Ethers," December 7, 2001, Prepared for the Statistics and Analytical Support Branch; Engineering and Analysis Division (4303T); U.S. Environmental Protection Agency; 1200 Pennsylvania Ave., NW; Washington, DC 20460
3. Congeners reported in "Proceedings of the 22nd International Symposium on Halogenated Environmental Pollutants and Persistent Organic Pollutants" (Dioxin 2002), Barcelona, Spain, August 11-16, 2002; *Organohalogen Compounds* **58** 161-249.
4. "Method 1668, Revision A: Chlorinated Biphenyl Congeners in Water, Soil, Sediment, and Tissue by HRGC/HRMS," December 1999, (EPA-821-R-00-002), Statistics and Analytical Support Branch; Engineering and Analysis Division (4303T); U.S. Environmental Protection Agency; 1200 Pennsylvania Ave., NW; Washington, DC 20460
5. "Analytical Method for the Determination of Polybrominated Diphenylethers by High Resolution GC/MS," July 9, 2002, (MLA-025, Rev 02), Axys Analytical Services, PO Box 2219, Sidney, BC, Canada V8L 3S8. The Axys method is proprietary and is not available.
6. "Working with Carcinogens," Department of Health, Education, & Welfare, Public Health Service, Centers for Disease Control, NIOSH, Publication 77-206, August 1977, NTIS PB-277256.
7. "OSHA Safety and Health Standards, General Industry," OSHA 2206, 29 CFR 1910.
8. "Safety in Academic Chemistry Laboratories," ACS Committee on Chemical Safety, 1979.
9. "Standard Methods for the Examination of Water and Wastewater," 18th and later editions, American Public Health Association, 1015 15th St, NW, Washington, DC 20005, 1-35: Section 1090 (Safety), 1992.
10. Lamparski, L.L., and Nestruck, T.J., "Novel Extraction Device for the Determination of Chlorinated Dibenzo-*p*-dioxins (PCDDs) and Dibenzofurans (PCDFs) in Matrices Containing Water," *Chemosphere*, 19:27-31, 1989.
11. Provost, L.P., and Elder, R.S., "Interpretation of Percent Recovery Data," *American Laboratory*, 15: 56-83, 1983.
12. "Standard Practice for Sampling Water," ASTM Annual Book of Standards, ASTM, 1916 Race Street, Philadelphia, PA 19103-1187, 1980.
13. "Methods 330.4 and 330.5 for Total Residual Chlorine," USEPA, EMSL, Cincinnati, OH 45268, EPA 600/4-70-020, March 1979.

14. "Handbook of Analytical Quality Control in Water and Wastewater Laboratories," USEPA EMSL, Cincinnati, OH 45268, EPA-600/4-79-019, March 1979.
15. Kuehl, D.W., B.C. Butterworth, J. Libal, and P. Marquis, "An Isotope Dilution High Resolution Gas Chromatography-High Resolution Mass Spectrometric Method for the Determination of Coplanar Polychlorinated Biphenyls: Application to Fish and Marine Mammals," *Chemosphere* 22:9-10, 849-858, 1991.
16. Tessari, J.D., Personal communication with Dale Rushneck, available from the EPA Sample Control Center, operated by DynCorp Environmental, 6101 Stevenson Avenue, Alexandria, VA 22304, 703-461-2100.
17. Ferrario, J.C., C. Byrne, A.E. Dupuy, Jr., "Background Contamination by Coplanar Polychlorinated Biphenyls (PCBs) in Trace Level High Resolution Gas Chromatography/High Resolution Mass Spectrometry (HRGC/HRMS) Analytical Procedures" *Chemosphere* 34:11, 2451-2465, 1997.
18. Initial information for this method was generously provided to EPA by Axys Analytical Systems and is contained in this method. No further report is available.

23.0 Tables and Figures

Table 1. Names and congener numbers for native and labeled bromodiphenyl ether (BDE) congeners determined by isotope dilution and internal standard HRGC/HRMS

| Native BDE congener | | Labeled analog ¹ | |
|-----------------------------------|---------------|--|---------|
| Name ² | Number | Name | Number |
| 2-MoBDE | BDE-1 | | |
| 3-MoBDE ³ | BDE-2 | | |
| 4-MoBDE | BDE-3 | ¹³ C ₁₂ -4-MoBDE | BDE-3L |
| 2,2'-DiBDE | BDE-4 | | |
| 2,3-DiBDE | BDE-5 | | |
| 2,3'-DiBDE | BDE-6 | | |
| 2,4-DiBDE ⁴ | BDE-7 | | |
| 2,4'-DiBDE ⁴ | BDE-8 | | |
| 2,5-DiBDE | BDE-9 | | |
| 2,6-DiBDE | BDE-10 | | |
| 3,3'-DiBDE | BDE-11 | | |
| 3,4-DiBDE ⁴ | BDE-12 | | |
| 3,4'-DiBDE ⁴ | BDE-13 | | |
| 3,5-DiBDE | BDE-14 | | |
| 4,4'-DiBDE ⁴ | BDE-15 | ¹³ C ₁₂ -4,4'-DiBDE | BDE-15L |
| 2,2',3-TrBDE | BDE-16 | | |
| 2,2',4-TrBDE ⁴ | BDE-17 | | |
| 2,2',5-TrBDE | BDE-18 | | |
| 2,2',6-TrBDE | BDE-19 | | |
| 2,3,3'-TrBDE | BDE-20 | | |
| 2,3,4-TrBDE | BDE-21 | | |
| 2,3,4'-TrBDE | BDE-22 | | |
| 2,3,5-TrBDE | BDE-23 | | |
| 2,3,6-TrBDE | BDE-24 | | |
| 2,3',4-TrBDE ⁴ | BDE-25 | | |
| 2,3',5-TrBDE | BDE-26 | | |
| 2,3',6-TrBDE | BDE-27 | | |
| 2,4,4'-TrBDE^{4,5} | BDE-28 | ¹³ C ₁₂ -2,4,4'-TriBDE | BDE-28L |
| 2,4,5-TrBDE | BDE-29 | | |
| 2,4,6-TrBDE ⁴ | BDE-30 | | |
| 2,4',5-TrBDE | BDE-31 | | |
| 2,4',6-TrBDE ⁴ | BDE-32 | | |
| 2',3,4-TrBDE ⁴ | BDE-33 | | |
| 2',3,5-TrBDE | BDE-34 | | |
| 3,3',4-TrBDE ⁴ | BDE-35 | | |
| 3,3',5-TrBDE | BDE-36 | | |
| 3,4,4'-TrBDE ⁴ | BDE-37 | | |
| 3,4,5-TrBDE | BDE-38 | | |

| Native BDE congener | | Labeled analog ¹ | |
|--------------------------------------|---------------|--|---------|
| Name ² | Number | Name | Number |
| 3,4',5-TrBDE | BDE-39 | | |
| 2,2',3,3'-TeBDE | BDE-40 | | |
| 2,2',3,4-TeBDE | BDE-41 | | |
| 2,2',3,4'-TeBDE | BDE-42 | | |
| 2,2',3,5-TeBDE | BDE-43 | | |
| 2,2',3,5'-TeBDE | BDE-44 | | |
| 2,2',3,6-TeBDE | BDE-45 | | |
| 2,2',3,6'-TeBDE | BDE-46 | | |
| 2,2',4,4'-TeBDE^{4,5} | BDE-47 | ¹³ C ₁₂ -2,2',4,4'-TeBDE | BDE-47L |
| 2,2',4,5-TeBDE | BDE-48 | | |
| 2,2',4,5'-TeBDE ⁴ | BDE-49 | | |
| 2,2',4,6-TeBDE | BDE-50 | | |
| 2,2',4,6'-TeBDE ⁴ | BDE-51 | | |
| 2,2',5,5'-TeBDE | BDE-52 | | |
| 2,2',5,6'-TeBDE | BDE-53 | | |
| 2,2',6,6'-TeBDE | BDE-54 | | |
| 2,3,3',4'-TeBDE | BDE-55 | | |
| 2,3,3',4'-TeBDE | BDE-56 | | |
| 2,3,3',5-TeBDE | BDE-57 | | |
| 2,3,3',5'-TeBDE | BDE-58 | | |
| 2,3,3',6-TeBDE | BDE-59 | | |
| 2,3,4,4'-TeBDE | BDE-60 | | |
| 2,3,4,5-TeBDE | BDE-61 | | |
| 2,3,4,6-TeBDE | BDE-62 | | |
| 2,3,4',5-TeBDE | BDE-63 | | |
| 2,3,4',6-TeBDE | BDE-64 | | |
| 2,3,5,6-TeBDE | BDE-65 | | |
| 2,3',4,4'-TeBDE ⁴ | BDE-66 | | |
| 2,3',4,5-TeBDE | BDE-67 | | |
| 2,3',4,5'-TeBDE | BDE-68 | | |
| 2,3',4,6-TeBDE | BDE-69 | | |
| 2,3',4',5-TeBDE | BDE-70 | | |
| 2,3',4',6-TeBDE ⁴ | BDE-71 | | |
| 2,3',5,5'-TeBDE | BDE-72 | | |
| 2,3',5',6-TeBDE | BDE-73 | | |
| 2,4,4',5-TeBDE | BDE-74 | | |
| 2,4,4',6-TeBDE ⁴ | BDE-75 | | |
| 2',3,4,5-TeBDE | BDE-76 | | |
| 3,3',4,4'-TeBDE ⁴ | BDE-77 | ¹³ C ₁₂ -3,3',4,4'-TeBDE | BDE-77L |
| 3,3',4,5-TeBDE | BDE-78 | | |
| 3,3',4,5'-TeBDE ⁴ | BDE-79 | | |
| 3,3',5,5'-TeBDE | BDE-80 | | |
| 3,4,4',5-TeBDE | BDE-81 | | |

| Native BDE congener | | Labeled analog ¹ | |
|--|----------------|--|----------|
| Name ² | Number | Name | Number |
| 2,2',3,3',4-PeBDE | BDE-82 | | |
| 2,2',3,3',5-PeBDE ⁴ | <i>BDE-83</i> | | |
| 2,2',3,3',6-PeBDE | BDE-84 | | |
| 2,2',3,4,4'-PeBDE ⁴ | <i>BDE-85</i> | | |
| 2,2',3,4,5-PeBDE | BDE-86 | | |
| 2,2',3,4,5'-PeBDE | BDE-87 | | |
| 2,2',3,4,6-PeBDE | BDE-88 | | |
| 2,2',3,4,6'-PeBDE | BDE-89 | | |
| 2,2',3,4',5-PeBDE | BDE-90 | | |
| 2,2',3,4',6-PeBDE | BDE-91 | | |
| 2,2',3,5,5'-PeBDE | BDE-92 | | |
| 2,2',3,5,6-PeBDE | BDE-93 | | |
| 2,2',3,5,6'-PeBDE | BDE-94 | | |
| 2,2',3,5',6-PeBDE | BDE-95 | | |
| 2,2',3,6,6'-PeBDE | BDE-96 | | |
| 2,2',3',4,5-PeBDE | BDE-97 | | |
| 2,2',3',4,6-PeBDE | BDE-98 | | |
| 2,2',4,4',5-PeBDE^{4,5} | BDE-99 | ¹³ C ₁₂ -2,2',4,4',5-PeBDE | BDE-99L |
| 2,2',4,4',6-PeBDE^{4,5} | BDE-100 | ¹³ C ₁₂ -2,2',4,4',6-PeBDE | BDE-100L |
| 2,2',4,5,5'-PeBDE | BDE-101 | | |
| 2,2',4,5,6'-PeBDE | BDE-102 | | |
| 2,2',4,5,'6-PeBDE | BDE-103 | | |
| 2,2',4,6,6'-PeBDE | BDE-104 | | |
| 2,3,3',4,4'-PeBDE ⁴ | <i>BDE-105</i> | | |
| 2,3,3',4,5-PeBDE | BDE-106 | | |
| 2,3,3',4',5-PeBDE | BDE-107 | | |
| 2,3,3',4,5'-PeBDE | BDE-108 | | |
| 2,3,3',4,6-PeBDE | BDE-109 | | |
| 2,3,3',4',6-PeBDE | BDE-110 | | |
| 2,3,3',5,5'-PeBDE | BDE-111 | | |
| 2,3,3',5,6-PeBDE | BDE-112 | | |
| 2,3,3',5',6-PeBDE | BDE-113 | | |
| 2,3,4,4',5-PeBDE | BDE-114 | | |
| 2,3,4,4',6-PeBDE | BDE-115 | | |
| 2,3,4,5,6-PeBDE ⁴ | <i>BDE-116</i> | | |
| 2,3,4',5,6-PeBDE | BDE-117 | | |
| 2,3',4,4',5-PeBDE | BDE-118 | | |
| 2,3',4,4',6-PeBDE ⁴ | <i>BDE-119</i> | | |
| 2,3',4,5,5'-PeBDE ⁴ | <i>BDE-120</i> | | |
| 2,3',4,5,'6-PeBDE | BDE-121 | | |
| 2',3,3',4,5-PeBDE | BDE-122 | | |
| 2',3,4,4',5-PeBDE | BDE-123 | | |
| 2',3,4,5,5'-PeBDE | BDE-124 | | |

| Native BDE congener | | Labeled analog ¹ | |
|-------------------------------------|---------|---|----------|
| Name ² | Number | Name | Number |
| 2',3,4,5,6'-PeBDE | BDE-125 | | |
| 3,3',4,4',5-PeBDE ⁴ | BDE-126 | ¹³ C ₁₂ -3,3',4,4',5-PeBDE | BDE-126L |
| 3,3',4,5,5'-PeBDE | BDE-127 | | |
| 2,2',3,3',4,4'-HxBDE ⁴ | BDE-128 | | |
| 2,2',3,3',4,5-HxBDE | BDE-129 | | |
| 2,2',3,3',4,5'-HxBDE | BDE-130 | | |
| 2,2',3,3',4,6-HxBDE | BDE-131 | | |
| 2,2',3,3',4,6'-HxBDE | BDE-132 | | |
| 2,2',3,3',5,5'-HxBDE | BDE-133 | | |
| 2,2',3,3',5,6-HxBDE | BDE-134 | | |
| 2,2',3,3',5,6'-HxBDE | BDE-135 | | |
| 2,2',3,3',6,6'-HxBDE | BDE-136 | | |
| 2,2',3,4,4',5-HxBDE | BDE-137 | | |
| 2,2',3,4,4',5'-HxBDE ⁴ | BDE-138 | | |
| 2,2',3,4,4',6-HxBDE | BDE-139 | ¹³ C ₁₂ -2,2',3,4,4',6-HxBDE | BDE-139L |
| 2,2',3,4,4',6'-HxBDE ⁴ | BDE-140 | | |
| 2,2',3,4,5,5'-HxBDE | BDE-141 | | |
| 2,2',3,4,5,6-HxBDE | BDE-142 | | |
| 2,2',3,4,5,6'-HxBDE | BDE-143 | | |
| 2,2',3,4,5',6-HxBDE | BDE-144 | | |
| 2,2',3,4,6,6'-HxBDE | BDE-145 | | |
| 2,2',3,4',5,5'-HxBDE | BDE-146 | | |
| 2,2',3,4',5,6-HxBDE | BDE-147 | | |
| 2,2',3,4',5,6'-HxBDE | BDE-148 | | |
| 2,2',3,4',5',6-HxBDE | BDE-149 | | |
| 2,2',3,4',6,6'-HxBDE | BDE-150 | | |
| 2,2',3,5,5',6-HxBDE | BDE-151 | | |
| 2,2',3,5,6,6'-HxBDE | BDE-152 | | |
| 2,2',4,4',5,5'-HxBDE ^{4,5} | BDE-153 | ¹³ C ₁₂ -2,2',4,4',5,5'-HxBDE | BDE-153L |
| 2,2',4,4',5',6-HxBDE ^{4,5} | BDE-154 | ¹³ C ₁₂ -2,2',4,4',5',6-HxBDE | BDE-154L |
| 2,2',4,4',6,6'-HxBDE ⁴ | BDE-155 | | |
| 2,3,3',4,4',5-HxBDE | BDE-156 | | |
| 2,3,3',4,4',5'-HxBDE | BDE-157 | | |
| 2,3,3',4,4',6-HxBDE | BDE-158 | | |
| 2,3,3',4,5,5'-HxBDE | BDE-159 | | |
| 2,3,3',4,5,6-HxBDE | BDE-160 | | |
| 2,3,3',4,5',6-HxBDE | BDE-161 | | |
| 2,3,3',4',5,5'-HxBDE | BDE-162 | | |
| 2,3,3',4',5,6-HxBDE | BDE-163 | | |
| 2,3,3',4',5',6-HxBDE | BDE-164 | | |
| 2,3,3',5,5',6-HxBDE | BDE-165 | | |
| 2,3,4,4',5,6-HxBDE ⁴ | BDE-166 | | |
| 2,3',4,4',5,5'-HxBDE | BDE-167 | | |

| Native BDE congener | | Labeled analog ¹ | |
|---|----------------|---|----------|
| Name ² | Number | Name | Number |
| 2,3',4,4',5',6-HxBDE | BDE-168 | | |
| 3,3',4,4',5,5'-HxBDE | BDE-169 | | |
| 2,2',3,3',4,4',5-HpBDE | BDE-170 | | |
| 2,2'3,3',4,4',6-HpBDE | BDE-171 | | |
| 2,2',3,3',4,5,5'-HpBDE | BDE-172 | | |
| 2,2',3,3',4,5,6-HpBDE | BDE-173 | | |
| 2,2',3,3',4,5,6'-HpBDE | BDE-174 | | |
| 2,2',3,3',4,5',6-HpBDE | BDE-175 | | |
| 2,2',3,3',4,6,6'-HpBDE | BDE-176 | | |
| 2,2',3,3',4',5,6-HpBDE | BDE-177 | | |
| 2,2',3,3',5,5',6-HpBDE | BDE-178 | | |
| 2,2',3,3',5,6,6'-HpBDE | BDE-179 | | |
| 2,2',3,4,4',5,5'-HpBDE | BDE-180 | | |
| 2,2',3,4,4',5,6-HpBDE ⁴ | <i>BDE-181</i> | | |
| 2,2',3,4,4',5,6'-HpBDE | BDE-182 | | |
| 2,2',3,4,4',5',6-HpBDE^{4,5} | BDE-183 | ¹³ C ₁₂ -2,2',3,4,4',5',6-HpBDE | BDE-183L |
| 2,2',3,4,4',6,6'-HpBDE | BDE-184 | | |
| 2,2',3,4,5,5',6-HpBDE | BDE-185 | | |
| 2,2',3,4,5,6,6'-HpBDE | BDE-186 | | |
| 2,2',3,4',5,5',6-HpBDE | BDE-187 | | |
| 2,2',3,4',5,6,6'-HpBDE | BDE-188 | | |
| 2,3,3',4,4',5,5'-HpBDE | BDE-189 | | |
| 2,3,3',4,4',5,6-HpBDE ⁴ | <i>BDE-190</i> | | |
| 2,3,3',4,4',5',6-HpBDE | BDE-191 | | |
| 2,3,3',4,5,5',6-HpBDE | BDE-192 | | |
| 2,3,3',4',5,5',6-HpBDE | BDE-193 | | |
| 2,2',3,3',4,4',5,5'-OcBDE | BDE-194 | | |
| 2,2',3,3',4,4',5,6-OcBDE | BDE-195 | | |
| 2,2',3,3',4,4',5,6'-OcBDE | BDE-196 | | |
| 2,2',3,3',4,4',6,6'-OcBDE | BDE-197 | | |
| 2,2',3,3',4,5,5',6-OcBDE | BDE-198 | | |
| 2,2',3,3',4,5,5',6'-OcBDE | BDE-199 | | |
| 2,2',3,3',4,5,6,6'-OcBDE | BDE-200 | | |
| 2,2',3,3',4,5',6,6'-OcBDE | BDE-201 | | |
| 2,2',3,3',5,5',6,6'-OcBDE | BDE-202 | | |
| 2,2',3,4,4',5,5',6-OcBDE ³ | BDE-203 | | |
| 2,2',3,4,4',5,6,6'-OcBDE | BDE-204 | | |
| 2,3,3',4,4',5,5',6-OcBDE | BDE-205 | | |
| 2,2',3,3',4,4',5,5',6-NoBDE | BDE-206 | | |
| 2,2',3,3',4,4',5,6,6'-NoBDE | BDE-207 | | |
| 2,2',3,3',4,5,5',6,6'-NoBDE ³ | BDE-208 | | |
| DeBDE^{4,5} | BDE-209 | ¹³ C ₁₂ -DeBDE | BDE-209L |

1. Labeled compound in standard solution
2. Abbreviations for levels of bromination
 - MoBDE = monobromodiphenyl ether
 - DiBDE = dibromodiphenyl ether
 - TrBDE = tribromodiphenyl ether
 - TeBDE = tetrabromodiphenyl ether
 - PeBDE = pentabromodiphenyl ether
 - HxBDE = hexabromodiphenyl ether
 - HpBDE = heptabromodiphenyl ether
 - OcBDE = octabromodiphenyl ether
 - NoBDE = nonabromodiphenyl ether
 - DeBDE = decabromodiphenyl ether
3. Congener suggested for coverage of this level of bromination
4. Congener (shown in italics) reported in the technical literature in EPA's 2001 literature survey
5. BDEs of primary interest (shown in bold) as determined at the "4th Annual Workshop on Brominated Flame Retardants in the Environment," June 17-18, 2002, Canada Centre for Inland Waters, Burlington, Ontario, Canada

Table 2. Retention times (RT), RT references, relative retention times (RRTs), method detection limits (MDLs), and minimum levels (MLs) for the selected BDE congeners on DB-5HT

| Br No. ¹ | Congener No. ^{2,3,4} | RT Ref ⁵ | RT (min:sec) ⁶ | RRT ⁷ | RRT limits ⁸ | Window (sec) ⁹ | Quantitation reference ¹⁰ | Detection limits and minimum levels - Matrix and concentration ¹¹ | | | | |
|--|-------------------------------|---------------------|---------------------------|------------------|-------------------------|---------------------------|--------------------------------------|--|-----|---------------|----|-----------------|
| | | | | | | | | Water (pg/L) | | Other (ng/kg) | | Extract (pg/μL) |
| | | | | | | | | MDL | ML | MDL | ML | ML |
| Compounds using PCB-52L (¹³C₁₂-2,2',5,5'-TeCB) as Labeled injection internal standard | | | | | | | | | | | | |
| Monobromodiphenyl ether | | | | | | | | | | | | |
| 1 | 1 | 3L | 11:26 | 0.9488 | 0.9350-0.9627 | ±10 | 3L | | | | | |
| 1 | 2 | 3L | 11:45 | 0.9751 | 0.9613-0.9889 | ±10 | 3L | 50 | 200 | 5 | 20 | 10 |
| 1 | 3 | 3L | 12:04 | 1.0014 | 0.9986-1.0055 | -2 +3 | 3L | | | | | |
| Dibromodiphenyl ethers | | | | | | | | | | | | |
| 2 | 10 | 15L | 15:48 | 0.8642 | 0.8459-0.8824 | ±20 | 15L | | | | | |
| 2 | 7 | 15L | 16:59 | 0.9289 | 0.9152-0.9426 | ±15 | 15L | | | | | |
| 2 | 8/11 | 15L | 17:32 | 0.9590 | 0.9499-0.9681 | ±10 | 15L | 40 | 100 | 4 | 10 | 5 |
| 2 | 12 | 15L | 17:50 | 0.9754 | 0.9663-0.9845 | ±10 | 15L | | | | | |
| 2 | 13 | 15L | 17:54 | 0.9790 | 0.9699-0.9881 | ±10 | 15L | | | | | |
| 2 | 15 | 15L | 18:18 | 1.0009 | 0.9991-1.0036 | -2 +3 | 15L | | | | | |
| Tribromodiphenyl ethers | | | | | | | | | | | | |
| 3 | 30 | 28L | 20:26 | 0.8955 | 0.8809-0.9102 | ±20 | 28L | | | | | |
| 3 | 32 | 28L | 21:45 | 0.9533 | 0.9459-0.9606 | ±10 | 28L | | | | | |
| 3 | 17 | 28L | 22:11 | 0.9722 | 0.9649-0.9795 | ±10 | 28L | 50 | 200 | 5 | 20 | 10 |
| 3 | 25 | 28L | 22:17 | 0.9766 | 0.9693-0.9839 | ±10 | 28L | | | | | |
| 3 | 28/33 | 28L | 22:49 | 1.0000 | 0.9985-1.0022 | -2 +3 | 28L | 20 | 50 | 2 | 5 | 2.5 |
| 3 | 35 | 28L | 23:14 | 1.0183 | 1.0110-1.0256 | ±10 | 28L | | | | | |
| 3 | 37 | 28L | 23:41 | 1.0380 | 1.0307-1.0453 | ±10 | 28L | | | | | |
| Tetrabromodiphenyl ethers | | | | | | | | | | | | |
| 4 | 75 | 47L | 26:04 | 0.9625 | 0.9563-0.9686 | ±10 | 47L/77L | 30 | 100 | 3 | 10 | 5 |
| 4 | 51 | 47L | 26:12 | 0.9674 | 0.9612-0.9735 | ±10 | 47L/77L | | | | | |
| 4 | 49 | 47L | 26:25 | 0.9754 | 0.9692-0.9815 | ±10 | 47L/77L | | | | | |
| 4 | 71 | 47L | 26:33 | 0.9803 | 0.9742-0.9865 | ±10 | 47L/77L | | | | | |

| Br No. ¹ | Congener No. ^{2,3,4} | RT Ref ⁵ | RT (min:sec) ⁶ | RRT ⁷ | RRT limits ⁸ | Window (sec) ⁹ | Quantitation reference ¹⁰ | Detection limits and minimum levels - Matrix and concentration ¹¹ | | | | |
|--|-------------------------------|---------------------|---------------------------|------------------|-------------------------|---------------------------|--------------------------------------|--|-----|---------------|----|-----------------|
| | | | | | | | | Water (pg/L) | | Other (ng/kg) | | Extract (pg/μL) |
| | | | | | | | | MDL | ML | MDL | ML | ML |
| 4 | 47 | 47L | 27:05 | 1.0000 | 0.9988-1.0018 | -2 +3 | 47L | 25 | 100 | 2.5 | 10 | 5 |
| 4 | 79 | 47L | 27:26 | 1.0123 | 1.0062-1.0185 | ±10 | 47L/77L | | | | | |
| 4 | 66 | 47L | 27:40 | 1.0215 | 1.0154-1.0277 | ±10 | 47L/77L | 20 | 50 | 2 | 5 | 2.5 |
| 4 | 77 | 77L | 28:34 | 1.0000 | 0.9988-1.0018 | -2 +3 | 77L | | | | | |
| Labeled compounds | | | | | | | | | | | | |
| 1 | 3L | PCB-52L | 12:03 | 0.6992 | 0.6702-0.7282 | ±30 | PCB-52L | | | | | |
| 2 | 15L | PCB-52L | 18:17 | 1.0609 | 1.0319-1.0899 | ±30 | PCB-52L | | | | | |
| 3 | 28L | PCB-52L | 22:49 | 1.3240 | 1.2950-1.3530 | ±30 | PCB-52L | | | | | |
| 4 | 47L | PCB-52L | 27:05 | 1.5716 | 1.5426-1.6006 | ±30 | PCB-52L | | | | | |
| 4 | 77L | PCB-52L | 28:34 | 1.6576 | 1.6286-1.6867 | ±30 | PCB-52L | | | | | |
| Compounds using PCB-138L (¹³C₁₂,2,2',3,4,4',5'-HxCB) as Labeled injection internal standard | | | | | | | | | | | | |
| Pentabromodiphenyl ethers | | | | | | | | | | | | |
| 5 | 100 | 100L | 30:10 | 1.0000 | 0.9989-1.0017 | -2 +3 | 100L | 20 | 50 | 2 | 5 | 2.5 |
| 5 | 119/120 | 100L | 30:28 | 1.0099 | 1.0044-1.0155 | ±10 | 99L/100L/126L | | | | | |
| 5 | 99 | 99L | 31:04 | 1.0005 | 0.9995-1.0021 | -2 +3 | 99L | 40 | 100 | 4 | 10 | 5 |
| 5 | 116 | 99L | 31:19 | 1.0086 | 1.0032-1.0140 | ±10 | 99L/100L/126L | | | | | |
| 5 | 85 | 126L | 32:34 | 0.9914 | 0.9863-0.9964 | ±10 | 99L/100L/126L | 40 | 100 | 4 | 10 | 5 |
| 5 | 126 | 126L | 32:51 | 1.0000 | 0.9990-1.0015 | -2 +3 | 126L | | | | | |
| 5 | 105 | 126L | 33:08 ¹² | 1.0086 | 1.0036-1.0137 | ±10 | 99L/100L/126L | | | | | |
| Hexabromodiphenyl ethers | | | | | | | | | | | | |
| 6 | 155 | 154L | 32:50 | 0.9816 | 0.9766-0.9865 | ±10 | 153L/154L | | | | | |
| 6 | 154 | 154L | 33:28 | 1.0005 | 0.9995-1.0020 | -2 +3 | 154L | 20 | 50 | 2 | 5 | 2.5 |
| 6 | 153 | 153L | 34:38 | 1.0005 | 0.9995-1.0019 | -2 +3 | 153L | 20 | 50 | 2 | 5 | 2.5 |
| 6 | 140 | 153L | 35:20 ¹² | 1.0207 | 1.0159-1.0255 | ±10 | 153L/154L | | | | | |
| 6 | 138/166 | 153L | 36:09 | 1.0443 | 1.0395-1.0491 | ±10 | 153L/154L | 40 | 100 | 4 | 10 | 5 |
| 6 | 128 | 153L | 37:43 | 1.0896 | 1.0823-1.0968 | ±15 | 153L/154L | | | | | |

| Br No. ¹ | Congener No. ^{2,3,4} | RT Ref ⁵ | RT (min:sec) ⁶ | RRT ⁷ | RRT limits ⁸ | Window (sec) ⁹ | Quantitation reference ¹⁰ | Detection limits and minimum levels - Matrix and concentration ¹¹ | | | | |
|---|-------------------------------|---------------------|---------------------------|------------------|-------------------------|---------------------------|--------------------------------------|--|------|---------------|-----|-----------------|
| | | | | | | | | Water (pg/L) | | Other (ng/kg) | | Extract (pg/μL) |
| | | | | | | | | MDL | ML | MDL | ML | ML |
| Heptabromodiphenyl ethers | | | | | | | | | | | | |
| 7 | 183 | 183L | 37:58 | 1.0000 | 0.9991-1.0013 | -2 +3 | 183L | 30 | 100 | 3 | 10 | 5 |
| 7 | 181 | 183L | 39:40 | 1.0448 | 1.0404-1.0492 | ±10 | 183L | | | | | |
| 7 | 190 | 183L | 39:54 | 1.0509 | 1.0465-1.0553 | ±10 | 183L | 20 | 50 | 2 | 5 | 2.5 |
| Octabromodiphenyl ether | | | | | | | | | | | | |
| 8 | 203 | 209L | 42:40 ¹² | 1.1282 | 1.1194-1.1370 | ±20 | 209L | | | | | |
| Nonabromodiphenyl ether | | | | | | | | | | | | |
| 9 | 208 | 209L | 45:33 | 0.9050 | 0.9000-0.9099 | ±15 | 209L | | | | | |
| 9 | 207 | 209L | 45:52 | 0.9113 | 0.9063-0.9162 | ±15 | 209L | | | | | |
| 9 | 206 | 209L | 46:31 | 0.9242 | 0.9192-0.9291 | ±15 | 209L | | | | | |
| Decabromodiphenyl ether | | | | | | | | | | | | |
| 10 | 209 | 209L | 50:20 | 1.0000 | 0.9993-0.1010 | -2 +3 | 209L | 700 | 2000 | 70 | 200 | 100 |
| Labeled compounds | | | | | | | | | | | | |
| 5 | 100L | PCB-138L | 30:10 | 1.2230 | 1.2095-1.2365 | ±20 | PCB-138L | | | | | |
| 5 | 99L | PCB-138L | 31:03 | 1.2588 | 1.2453-1.2723 | ±20 | PCB-138L | | | | | |
| 5 | 126L | PCB-138L | 32:50 | 1.3318 | 1.3115-1.3520 | ±30 | PCB-138L | | | | | |
| 6 | 154L | PCB-138L | 33:27 | 1.3561 | 1.3358-1.3764 | ±30 | PCB-138L | | | | | |
| 6 | 153L | PCB-138L | 34:37 | 1.4034 | 1.3831-1.4236 | ±30 | PCB-138L | | | | | |
| 7 | 183L | PCB-138L | 37:58 | 1.5392 | 1.4986-1.5797 | ±60 | PCB-138L | | | | | |
| 10 | 209L | PCB-138L | 50:20 | 2.0405 | 2.0000-2.0811 | ±60 | PCB-138L | | | | | |
| Labeled clean-up standard | | | | | | | | | | | | |
| 6 | 139L | 153L | 35:03 | 1.0125 | 1.0077-1.0173 | ±10 | PCB-138L | | | | | |
| Labeled injection internal standards | | | | | | | | | | | | |
| 4 | PCB-52L | PCB-138L | 17:14 | 0.6986 | 0.6581-0.7392 | ±60 | PCB-138L | | | | | |
| 6 | PCB-138L | PCB-138L | 24:40 | 1.0000 | 1.0000-1.0000 | ±100 | PCB-138L | | | | | |

1. Number of bromines on congener.
2. Suffix "L" indicates labeled compound.
3. Two congeners in a cell indicate a coelution.
4. BDEs of primary interest are shown in **boldface**.
5. Retention time reference that is used to locate the target congener.
6. Retention time (RT) of the target congener.
7. Relative retention time (RRT) between the RT for the congener and RT for the reference.
8. Limits based on the magnitude of the RRT, adjusted for closely eluted isomers.
9. Window width for congener or congener pair.
10. Labeled congeners that form the quantitation reference. Areas from the exact m/zs of the congeners listed in the quantitation reference are summed, and divided by the number of congeners in the quantitation reference. For example, for congener 75, the areas at the exact m/zs for 47L and 77L are summed and the sum is divided by 2 (because there are 2 congeners in the quantitation reference).
11. MDLs for "Other" matrix calculated per procedure at 40 CFR 136, appendix B; MLs for "Other" matrix calculated per procedure at 68 FR 11790 (March 12, 2003); MDLs and MLs for aqueous matrix calculated as 10 times the MDLs and MLs for the "Other" matrix. MDLs and MLs for congeners for which MDLs and MLs are not shown will be similar to the MDLs and MLs for congeners at the same level of bromination.
12. Estimated

Table 3. Concentrations of native and labeled brominated diphenyl ethers in stock solutions, spiking solutions, and final extracts

| BDE congener | Solution concentrations | | |
|--|--------------------------------|-----------------|-----------------|
| | Stock (µg/mL) | Spiking (ng/mL) | Extract (ng/mL) |
| Native congener by isotope dilution | | | |
| 28 | 20 | 1.0 | 50 |
| 47 | 20 | 1.0 | 50 |
| 99 | 20 | 1.0 | 50 |
| 100 | 20 | 1.0 | 50 |
| 153 | 20 | 1.0 | 50 |
| 154 | 20 | 1.0 | 50 |
| 183 | 20 | 1.0 | 50 |
| 209 | 200 | 10 | 500 |
| Labeled BDE Congener | | | |
| 28L | 1.0 | 2.0 | 100 |
| 47L | 1.0 | 2.0 | 100 |
| 99L | 1.0 | 2.0 | 100 |
| 100L | 1.0 | 2.0 | 100 |
| 153L | 1.0 | 2.0 | 100 |
| 154L | 1.0 | 2.0 | 100 |
| 183L | 1.0 | 2.0 | 100 |
| 209L | 10 | 20 | 1000 |
| Labeled clean-up | | | |
| 139L | 1.0 | 2.0 | 100 |
| Labeled injection internal | | | |
| PCB-52L | 5 | 1000 | 100 |
| PCB-138L | 5 | 1000 | 100 |
| Diluted combined congener | | | |
| | Solution concentration (ng/mL) | | |
| Standard | Native | Labeled | |
| Native congeners | | | |
| MoBDE thru NoBDE | 50 | | |
| DeBDE | 500 | | |
| Labeled congeners | | | |
| MoBDE thru NoBDE | | 100 | |
| DeBDE | | 1000 | |
| Labeled cleanup | | 100 | |
| Labeled injection internal | | 100 | |

Table 4. Composition of individual native BDE congener solutions¹

| Solution Identifier | |
|----------------------------|---------------|
| BDE-A1 | BDE-A2 |
| 1 | 11 |
| 2 | 13 |
| 3 | 25 |
| 10 | 33 |
| 7 | 51 |
| 8 | 71 |
| 12 | 79 |
| 15 | 120 |
| 30 | 116 |
| 32 | 155 |
| 17 | 105 |
| 28 | 166 |
| 35 | 183 |
| 37 | 190 |
| 75 | 207 |
| 49 | |
| 47 | |
| 66 | |
| 77 | |
| 100 | |
| 119 | |
| 99 | |
| 85 | |
| 126 | |
| 154 | |
| 153 | |
| 140 | |
| 138 | |
| 128 | |
| 181 | |
| 203 | |
| 208 | |
| 206 | |
| 209 | |
| Totals | |
| 34 | 15 |

1. Congeners listed by congener number in retention time order in each solution. See Table 3 for concentrations of congeners in stock solutions and Table 5 for concentrations in calibration standards.

Table 5. Concentration of BDE congeners in calibration and calibration verification standards¹

| BDE congener | Congener number ² | Solution concentration (ng/mL) | | | | |
|---|------------------------------|--------------------------------|------|------------|------|-------|
| | | CS-1 | CS-2 | CS-3 (VER) | CS-4 | CS-5 |
| Native | | | | | | |
| 2,4,4'-TrBDE | 28 | 1.0 | 5.0 | 50 | 500 | 2500 |
| 2,2',4,4'-TeBDE | 47 | 1.0 | 5.0 | 50 | 500 | 2500 |
| 2,2',4,4',5-PeBDE | 99 | 1.0 | 5.0 | 50 | 500 | 2500 |
| 2,2',4,4',6-PeBDE | 100 | 1.0 | 5.0 | 50 | 500 | 2500 |
| 2,2',4,4',5,5'-HxBDE | 153 | 1.0 | 5.0 | 50 | 500 | 2500 |
| 2,2',4,4',5',6-HxBDE | 154 | 1.0 | 5.0 | 50 | 500 | 2500 |
| 2,2',3,4,4',5',6-HpBDE | 183 | 1.0 | 5.0 | 50 | 500 | 2500 |
| DeBDE | 209 | 10 | 50 | 500 | 5000 | 25000 |
| Labeled | | | | | | |
| ¹³ C ₁₂ -2,4,4'-TrBDE | 28L | 100 | 100 | 100 | 100 | 100 |
| ¹³ C ₁₂ -2,2',4,4'-TeBDE | 47L | 100 | 100 | 100 | 100 | 100 |
| ¹³ C ₁₂ -2,2',4,4',5-PeBDE | 99L | 100 | 100 | 100 | 100 | 100 |
| ¹³ C ₁₂ -2,2',4,4',6-PeBDE | 100L | 100 | 100 | 100 | 100 | 100 |
| ¹³ C ₁₂ -2,2',4,4',5,5'-HxBDE | 153L | 100 | 100 | 100 | 100 | 100 |
| ¹³ C ₁₂ -2,2',4,4',5',6-HxBDE | 154L | 100 | 100 | 100 | 100 | 100 |
| ¹³ C ₁₂ -2,2',3,4,4',5',6-HpBDE | 183L | 100 | 100 | 100 | 100 | 100 |
| ¹³ C ₁₂ -DeBDE | 209L | 1000 | 1000 | 1000 | 1000 | 1000 |
| Labeled clean-up | | | | | | |
| ¹³ C ₁₂ -2,2',3,4,4',6-HxBDE | 139L | 100 | 100 | 100 | 100 | 100 |
| Labeled injection internal | | | | | | |
| ¹³ C ₁₂ -2,2',5,5'-TeCB | PCB-52L | 100 | 100 | 100 | 100 | 100 |
| ¹³ C ₁₂ -2,2',3,4,4',5'-HxCB | PCB-138L | 100 | 100 | 100 | 100 | 100 |

1. Other congeners may be included in calibration solutions if desired.
2. Suffix "L" indicates labeled compound

Table 6. QC acceptance criteria for bromodiphenyl ethers in VER, IPR, OPR, and samples¹

| Congener ² | Congener number ³ | Test conc (ng/mL) ⁴ | VER ⁵ (%) | IPR | | OPR (%) | Labeled compound recovery in samples (%) |
|---|------------------------------|--------------------------------|----------------------|---------|--------|---------|--|
| | | | | RSD (%) | X (%) | | |
| Native congeners | | | | | | | |
| 2,4,4'-TrBDE | 28 | 50 | 70-130 | 40 | 60-140 | 50-150 | |
| 2,2',4,4'TeBDE | 47 | 50 | 70-130 | 40 | 60-140 | 50-150 | |
| 2,2',4,4',5-PeBDE | 99 | 50 | 70-130 | 40 | 60-140 | 50-150 | |
| 2,2',4,4',6-PeBDE | 100 | 50 | 70-130 | 40 | 60-140 | 50-150 | |
| 2,2',4,4',5,5'-HxBDE | 153 | 50 | 70-130 | 40 | 60-140 | 50-150 | |
| 2,2',4,4',5',6-HxBDE | 154 | 50 | 70-130 | 40 | 60-140 | 50-150 | |
| 2,2',3,4,4',5',6-HpBDE | 183 | 50 | 70-130 | 40 | 60-140 | 50-150 | |
| DeBDE | 209 | 500 | 50-200 | 40 | 50-200 | 40-200 | |
| Labeled congeners | | | | | | | |
| ¹³ C ₁₂ -2,4,4'-TrBDE | 28L | 100 | 50-150 | 50 | 35-135 | 30-140 | 25-150 |
| ¹³ C ₁₂ -2,2',4,4'-TeBDE | 47L | 100 | 50-150 | 50 | 35-135 | 30-140 | 25-150 |
| ¹³ C ₁₂ -2,2',4,4',5-PeBDE | 99L | 100 | 50-150 | 50 | 35-135 | 30-140 | 25-150 |
| ¹³ C ₁₂ -2,2',4,4',6-PeBDE | 100L | 100 | 50-150 | 50 | 35-135 | 30-140 | 25-150 |
| ¹³ C ₁₂ -2,2',4,4',5,5'-HxBDE | 153L | 100 | 50-150 | 50 | 35-135 | 30-140 | 25-150 |
| ¹³ C ₁₂ -2,2',4,4',5',6-HxBDE | 154L | 100 | 50-150 | 50 | 35-135 | 30-140 | 25-150 |
| ¹³ C ₁₂ -2,2',3,4,4',5',6-HpBDE | 183L | 100 | 50-150 | 50 | 35-135 | 30-140 | 25-150 |
| ¹³ C ₁₂ -DeBDE | 209L | 1000 | 25-200 | 50 | 25-200 | 20-200 | 20-200 |
| Cleanup standard | | | | | | | |
| ¹³ C ₁₂ -2,2',3,4,4',6-HxBDE | 139L | 100 | 60-130 | 45 | 45-120 | 40-125 | 30-135 |

1. QC acceptance criteria for IPR, OPR, and samples based on a 20 µL extract final volume
2. Other congeners may be included in test solutions if desired.
3. Suffix "L" indicates labeled compound.
4. See Table 5.
5. Section 15.3.

Table 7. Scan descriptors, levels of bromination and chlorination, m/zs, and BDEs and PCBs monitored by HRGC/HRMS

| Function and bromine or chlorine level | m/z ¹ | m/z type | m/z formula | Substance |
|--|------------------|----------|--|-------------------------------------|
| Fn-1; Br-1 | 247.9837 | M | ¹² C ₁₂ H ₉ ¹⁶ O ⁷⁹ Br | MoBDE |
| | 249.9816 | M+2 | ¹² C ₁₂ H ₉ ¹⁶ O ⁸¹ Br | MoBDE |
| | 260.0239 | M | ¹³ C ₁₂ H ₉ ¹⁶ O ⁷⁹ Br | ¹³ C ₁₂ MoBDE |
| | 262.0219 | M+2 | ¹³ C ₁₂ H ₉ ¹⁶ O ⁸¹ Br | ¹³ C ₁₂ MoBDE |
| | 280.9824 | lock | ¹² C ₆ F ₁₁ | PFK |
| Fn-2; Br-2; Cl-4 | 301.9626 | M | ¹³ C ₁₂ H ₆ ³⁵ Cl ₄ | ¹³ C ₁₂ TeCB |
| | 303.9597 | M+2 | ¹³ C ₁₂ H ₆ ³⁵ Cl ₃ ³⁷ Cl | ¹³ C ₁₂ TeCB |
| | 325.8942 | M | ¹² C ₁₂ H ₈ ¹⁶ O ⁷⁹ Br ₂ | DiBDE |
| | 327.8921 | M+2 | ¹² C ₁₂ H ₈ ¹⁶ O ⁷⁹ Br ⁸¹ Br | DiBDE |
| | 330.9792 | lock | ¹² C ₇ F ₁₃ | PFK |
| | 337.9344 | M | ¹³ C ₁₂ H ₈ ¹⁶ O ⁷⁹ Br ₂ | ¹³ C ₁₂ DiBDE |
| | 339.9324 | M+2 | ¹³ C ₁₂ H ₈ ¹⁶ O ⁷⁹ Br ⁸¹ Br | ¹³ C ₁₂ DiBDE |
| Fn-3 Br-3; Br-4; Cl-6 | 371.8817 | M+2 | ¹³ C ₁₂ H ₅ ³⁵ Cl ₅ ³⁷ Cl | ¹³ C ₁₂ HxCB |
| | 373.8788 | M+4 | ¹³ C ₁₂ H ₆ ³⁵ Cl ₄ ³⁷ Cl ₂ | ¹³ C ₁₂ HxCB |
| | 405.8027 | M+2 | ¹² C ₁₂ H ₇ ¹⁶ O ⁷⁹ Br ₂ ⁸¹ Br | TrBDE |
| | 407.8002 | M+4 | ¹² C ₁₂ H ₇ ¹⁶ O ⁷⁹ Br ⁸¹ Br ₂ | TrBDE |
| | 417.8429 | M+2 | ¹³ C ₁₂ H ₇ ¹⁶ O ⁷⁹ Br ₂ ⁸¹ Br | ¹³ C ₁₂ TrBDE |
| | 419.8409 | M+4 | ¹³ C ₁₂ H ₇ ¹⁶ O ⁷⁹ Br ⁸¹ Br ₂ | ¹³ C ₁₂ TrBDE |
| | 442.9728 | lock | ¹² C ₁₀ F ₁₇ | PFK |
| | 483.7132 | M+2 | ¹² C ₁₂ H ₆ ¹⁶ O ⁷⁹ Br ₃ ⁸¹ Br | TeBDE |
| | 485.7111 | M+4 | ¹² C ₁₂ H ₆ ¹⁶ O ⁷⁹ Br ₂ ⁸¹ Br ₂ | TeBDE |
| | 497.7514 | M+4 | ¹³ C ₁₂ H ₆ ¹⁶ O ⁷⁹ Br ₂ ⁸¹ Br ₂ | ¹³ C ₁₂ TeBDE |
| | 499.7493 | M+6 | ¹³ C ₁₂ H ₆ ¹⁶ O ⁷⁹ Br ⁸¹ Br ₃ | ¹³ C ₁₂ TeBDE |
| Fn-4; Br-5; Br-6 | 554.9665 | lock | ¹² C ₁₃ F ₂₁ | PFK |
| | 563.6216 | M+4 | ¹² C ₁₂ H ₅ ¹⁶ O ⁷⁹ Br ₃ ⁸¹ Br ₂ | PeBDE |
| | 565.6196 | M+6 | ¹² C ₁₂ H ₅ ¹⁶ O ⁷⁹ Br ₂ ⁸¹ Br ₃ | PeBDE |
| | 575.6619 | M+4 | ¹³ C ₁₂ H ₅ ¹⁶ O ⁷⁹ Br ₃ ⁸¹ Br ₂ | ¹³ C ₁₂ PeBDE |
| | 577.6598 | M+6 | ¹³ C ₁₂ H ₅ ¹⁶ O ⁷⁹ Br ₂ ⁸¹ Br ₃ | ¹³ C ₁₂ PeBDE |
| | 641.5322 | M+4 | ¹² C ₁₂ H ₄ ¹⁶ O ⁷⁹ Br ₄ ⁸¹ Br ₂ | HxBDE |
| | 643.5302 | M+6 | ¹² C ₁₂ H ₄ ¹⁶ O ⁷⁹ Br ₃ ⁸¹ Br ₃ | HxBDE |
| | 655.5704 | M+6 | ¹³ C ₁₂ H ₄ ¹⁶ O ⁷⁹ Br ₃ ⁸¹ Br ₃ | ¹³ C ₁₂ HxBDE |
| | 657.5683 | M+8 | ¹³ C ₁₂ H ₄ ¹⁶ O ⁷⁹ Br ₂ ⁸¹ Br ₄ | ¹³ C ₁₂ HxBDE |

| Function and bromine or chlorine level | m/z ¹ | m/z type | m/z formula | Substance |
|--|------------------|----------|--|-------------------------------------|
| Fn-5; Br-7; Br-8 | 716.9569 | lock | ¹² C ₁₇ F ₂₇ | PFK |
| | 721.4406 | M+6 | ¹² C ₁₂ H ₃ ¹⁶ O ⁷⁹ Br ₄ ⁸¹ Br ₃ | HpBDE |
| | 723.4386 | M+8 | ¹² C ₁₂ H ₃ ¹⁶ O ⁷⁹ Br ₃ ⁸¹ Br ₄ | HpBDE |
| | 733.4809 | M+6 | ¹³ C ₁₂ H ₃ ¹⁶ O ⁷⁹ Br ₄ ⁸¹ Br ₃ | ¹³ C ₁₂ HpBDE |
| | 735.4788 | M+8 | ¹³ C ₁₂ H ₃ ¹⁶ O ⁷⁹ Br ₃ ⁸¹ Br ₄ | ¹³ C ₁₂ HpBDE |
| | 799.3511 | M+6 | ¹² C ₁₂ H ₂ ¹⁶ O ⁷⁹ Br ₅ ⁸¹ Br ₃ | OcBDE |
| | 801.3491 | M+8 | ¹² C ₁₂ H ₂ ¹⁶ O ⁷⁹ Br ₄ ⁸¹ Br ₄ | OcBDE |
| | 811.3914 | M+6 | ¹³ C ₁₂ H ₂ ¹⁶ O ⁷⁹ Br ₅ ⁸¹ Br ₃ | ¹³ C ₁₂ OcBDE |
| | 813.3893 | M+8 | ¹³ C ₁₂ H ₂ ¹⁶ O ⁷⁹ Br ₄ ⁸¹ Br ₄ | ¹³ C ₁₂ OcBDE |
| Fn-6; Br-9; Br-10 | 879.2596 | M+8 | ¹² C ₁₂ H ¹⁶ O ⁷⁹ Br ₅ ⁸¹ Br ₄ | NoBDE |
| | 881.2575 | M+10 | ¹² C ₁₂ H ¹⁶ O ⁷⁹ Br ₄ ⁸¹ Br ₅ | NoBDE |
| | 891.2998 | M+8 | ¹³ C ₁₂ H ¹⁶ O ⁷⁹ Br ₅ ⁸¹ Br ₄ | ¹³ C ₁₂ NoBDE |
| | 892.9441 | lock | ¹² C ₁₉ F ₃₅ | PFK |
| | 893.2978 | M+10 | ¹³ C ₁₂ H ¹⁶ O ⁷⁹ Br ₄ ⁸¹ Br ₅ | ¹³ C ₁₂ NoBDE |
| | 957.1701 | M+8 | ¹² C ₁₂ ¹⁶ O ⁷⁹ Br ₆ ⁸¹ Br ₄ | DeBDE |
| | 959.1680 | M+10 | ¹² C ₁₂ ¹⁶ O ⁷⁹ Br ₅ ⁸¹ Br ₅ | DeBDE |
| | 971.2083 | M+10 | ¹³ C ₁₂ ¹⁶ O ⁷⁹ Br ₅ ⁸¹ Br ₅ | ¹³ C ₁₂ DeBDE |
| | 973.2063 | M+12 | ¹³ C ₁₂ ¹⁶ O ⁷⁹ Br ₄ ⁸¹ Br ₆ | ¹³ C ₁₂ DeBDE |

1. Isotopic masses used for accurate mass calculation

| | |
|------------------|---------|
| ¹ H | 1.0078 |
| ¹² C | 12.0000 |
| ¹³ C | 13.0034 |
| ¹⁶ O | 15.9949 |
| ³⁵ Cl | 34.9689 |
| ³⁷ Cl | 36.9659 |
| ⁷⁹ Br | 78.9813 |
| ⁸¹ Br | 80.9163 |
| ¹⁹ F | 18.9984 |

Table 8. Theoretical ion abundance ratios and QC limits

| Bromine atoms | m/zs forming ratio | Theoretical ratio | Lower QC limit | Upper QC limit |
|-----------------------|---------------------------|--------------------------|-----------------------|-----------------------|
| 1 | m/m+2 | 1.03 | 0.88 | 1.18 |
| 2 | m/(m+2) | 0.43 | 0.47 | 0.59 |
| 3 | (m+2)/(m+4) | 1.03 | 0.88 | 1.18 |
| 4 | (m+2)/(m+4) | 0.70 | 0.60 | 0.81 |
| | (m+4)/(m+6) | 1.54 | 1.31 | 1.77 |
| 5 | (m+4)/(m+6) | 1.03 | 0.88 | 1.18 |
| 6 | (m+4)/(m+6) | 0.77 | 0.65 | 0.89 |
| | (m+6)/(m+8) | 1.37 | 1.16 | 1.58 |
| 7 | (m+6)/(m+8) | 1.03 | 0.88 | 1.18 |
| 8 | (m+6)/(m+8) | 0.82 | 0.70 | 0.94 |
| 9 | (m+8)/(m+10) | 1.03 | 0.88 | 1.18 |
| 10 | (m+8)/(m+10) | 0.73 | 0.86 | 0.99 |
| Chlorine atoms | | | | |
| 4 | m/(m+2) | 0.78 | 0.66 | 0.90 |
| 6 | (m+2)/(m+4) | 1.25 | 1.06 | 1.44 |

Table 9. Suggested Sample Quantities to be Extracted for Various Matrices¹

| Sample matrix ² | Example | Percent solids | Phase | Quantity extracted |
|----------------------------|---------------------------|----------------|-----------------|--------------------|
| Single-phase | | | | |
| Aqueous | Drinking water | <1 | — ³ | 1000 mL |
| | Groundwater | | | |
| | Treated wastewater | | | |
| Solid | Dry soil | >20 | Solid | 10 g |
| | Compost | | | |
| | Ash | | | |
| | Waste oil | | | |
| | Organic polymer | | | |
| Tissue | Fish Human adipose | — | Organic | 10 g |
| Multi-phase | | | | |
| <i>Liquid/Solid</i> | | | | |
| Aqueous/Solid | Wet soil | 1-30 | Solid | 10 g |
| | Untreated effluent | | | |
| | Digested municipal sludge | | | |
| | Filter cake | | | |
| | Paper pulp | | | |
| Organic/solid | Industrial sludge | 1-100 | Both | 10 g |
| | Oily waste | | | |
| <i>Liquid/Liquid</i> | | | | |
| Aqueous/organic | In-process effluent | <1 | Organic | 10 g |
| | Untreated effluent | | | |
| | Drum waste | | | |
| Aqueous/organic/solid | Untreated effluent | >1 | Organic & solid | 10 g |
| | Drum waste | | | |

1. The quantity of sample to be extracted is adjusted to provide 10 g of solids (dry weight). One liter of aqueous samples containing one percent solids will contain 10 grams of solids. For aqueous samples containing greater than one percent solids, a lesser volume is used so that 10 grams of solids (dry weight) will be extracted.

2. The sample matrix may be amorphous for some samples. In general, when the BDEs are in contact with a multi-phase system in which one of the phases is water, they will be preferentially dispersed in or adsorbed on the alternate phase because of their low solubility in water.

3. Aqueous samples are filtered after spiking with the labeled compounds. The filtrate and the materials trapped on the filter are extracted separately, and the extracts are combined for cleanup and analysis.

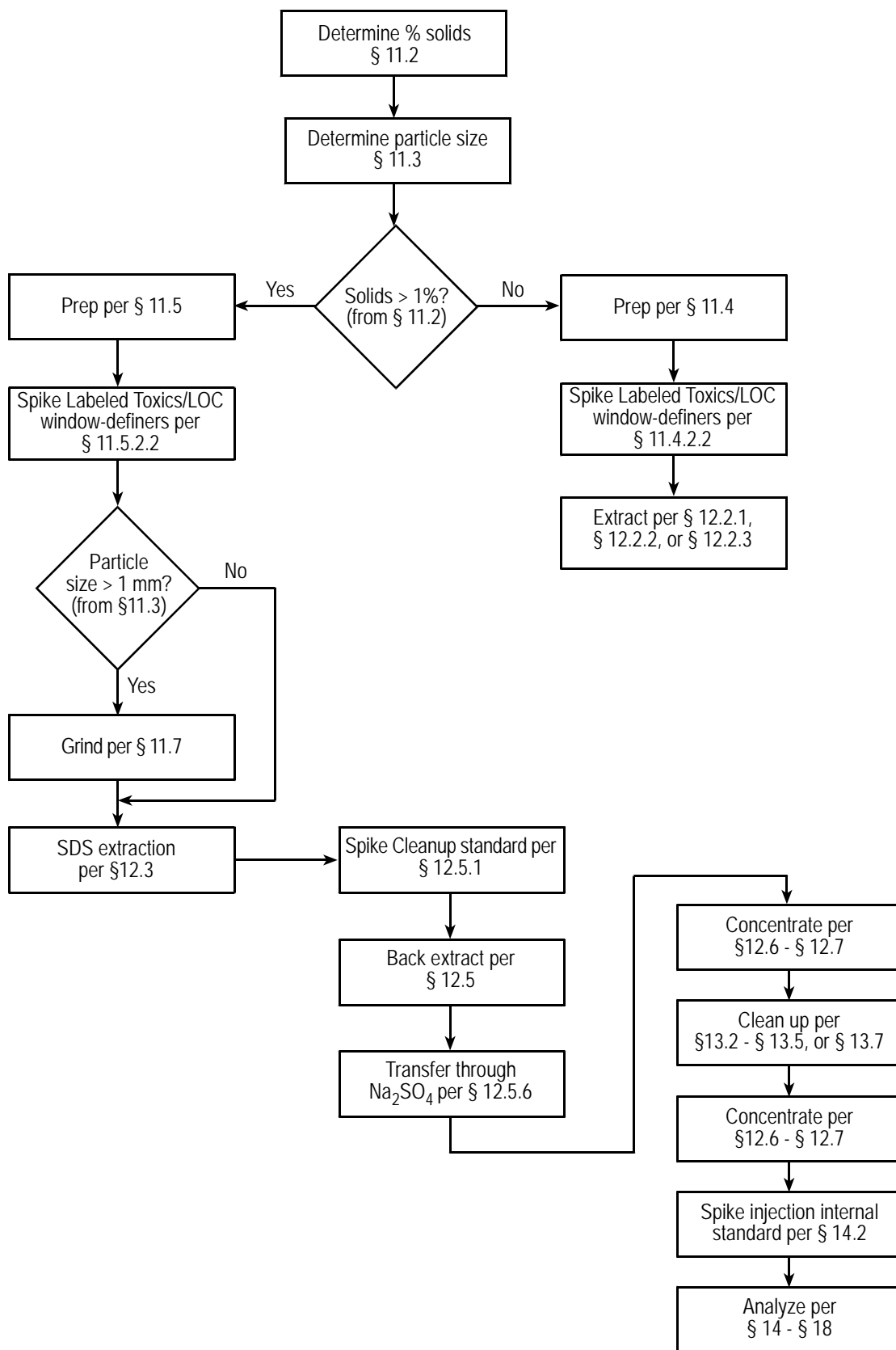

SCC-99-020

Figure 1 Flow Chart for Analysis of Aqueous and Solid Samples

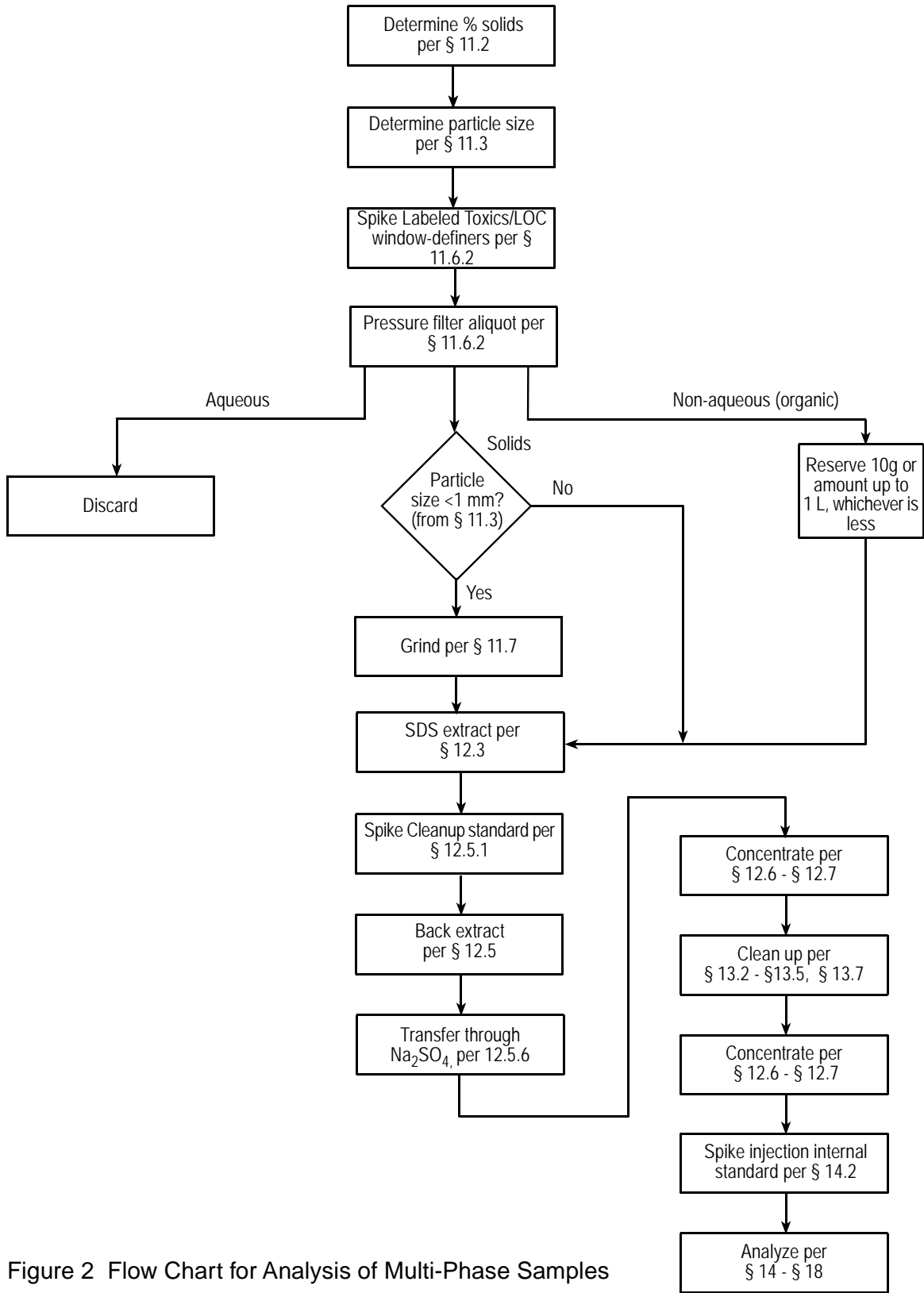

Figure 2 Flow Chart for Analysis of Multi-Phase Samples

SCC-99-018

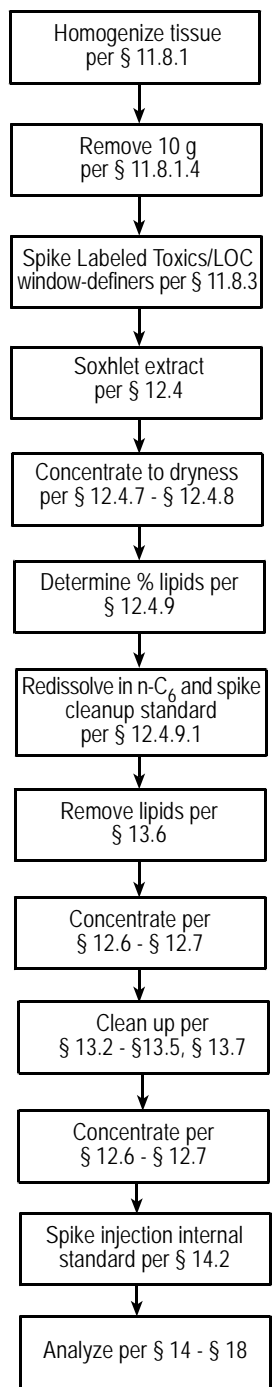

Figure 3 Flow Chart for Analysis of Tissue Samples

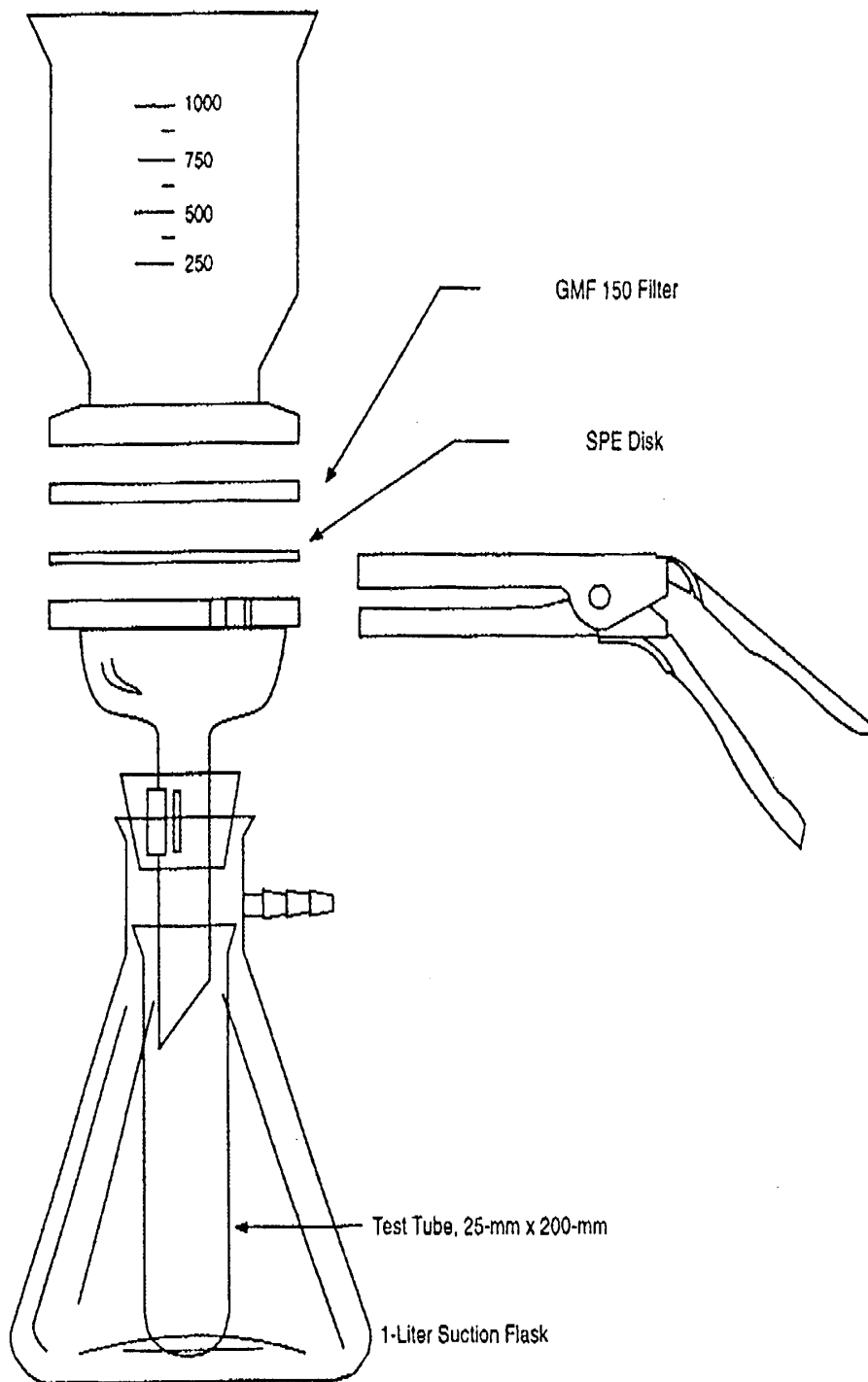
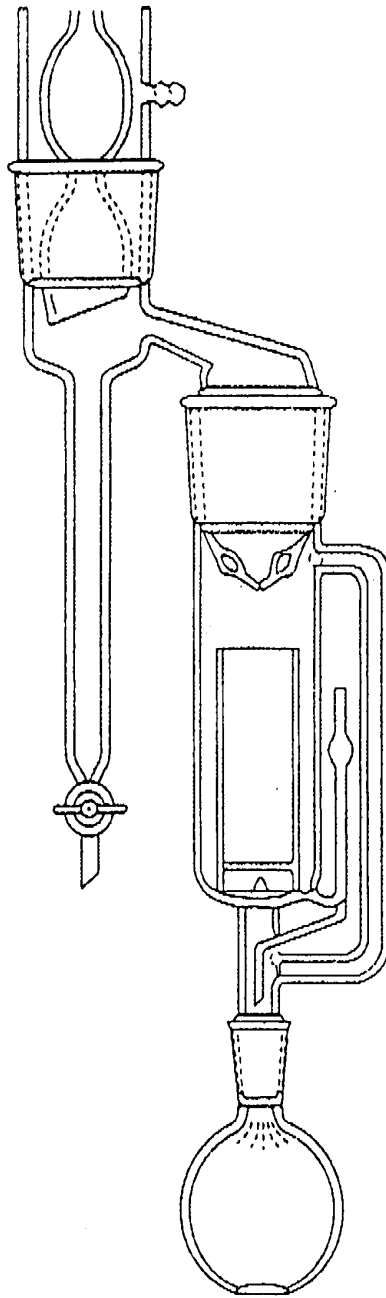

Figure 4 Solid-phase Extraction Apparatus



62-027-02

Figure 5 Soxhlet/Dean-Stark Extractor

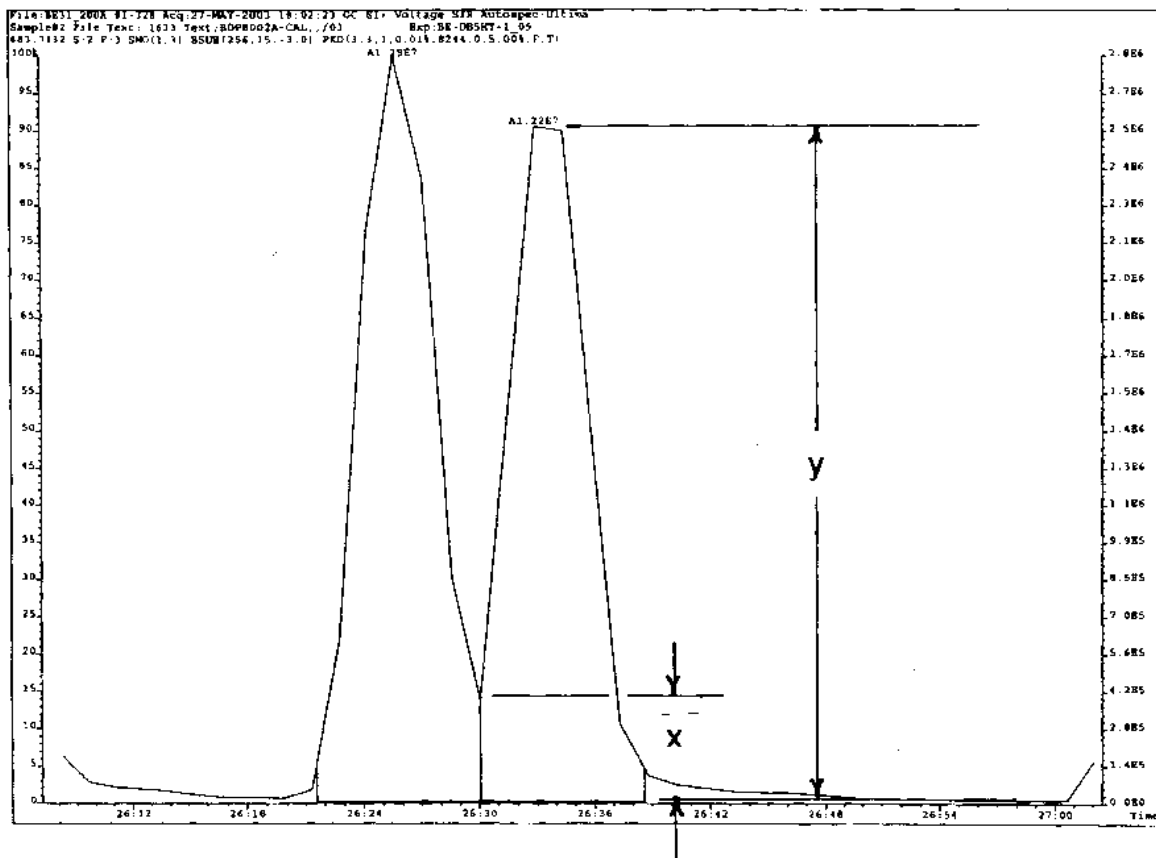

Figure 6 DB-5HT column resolution test: Separation of Br-4 congeners 49 and 71 with valley less than 40% (i.e. $100 x/y < 40\%$)

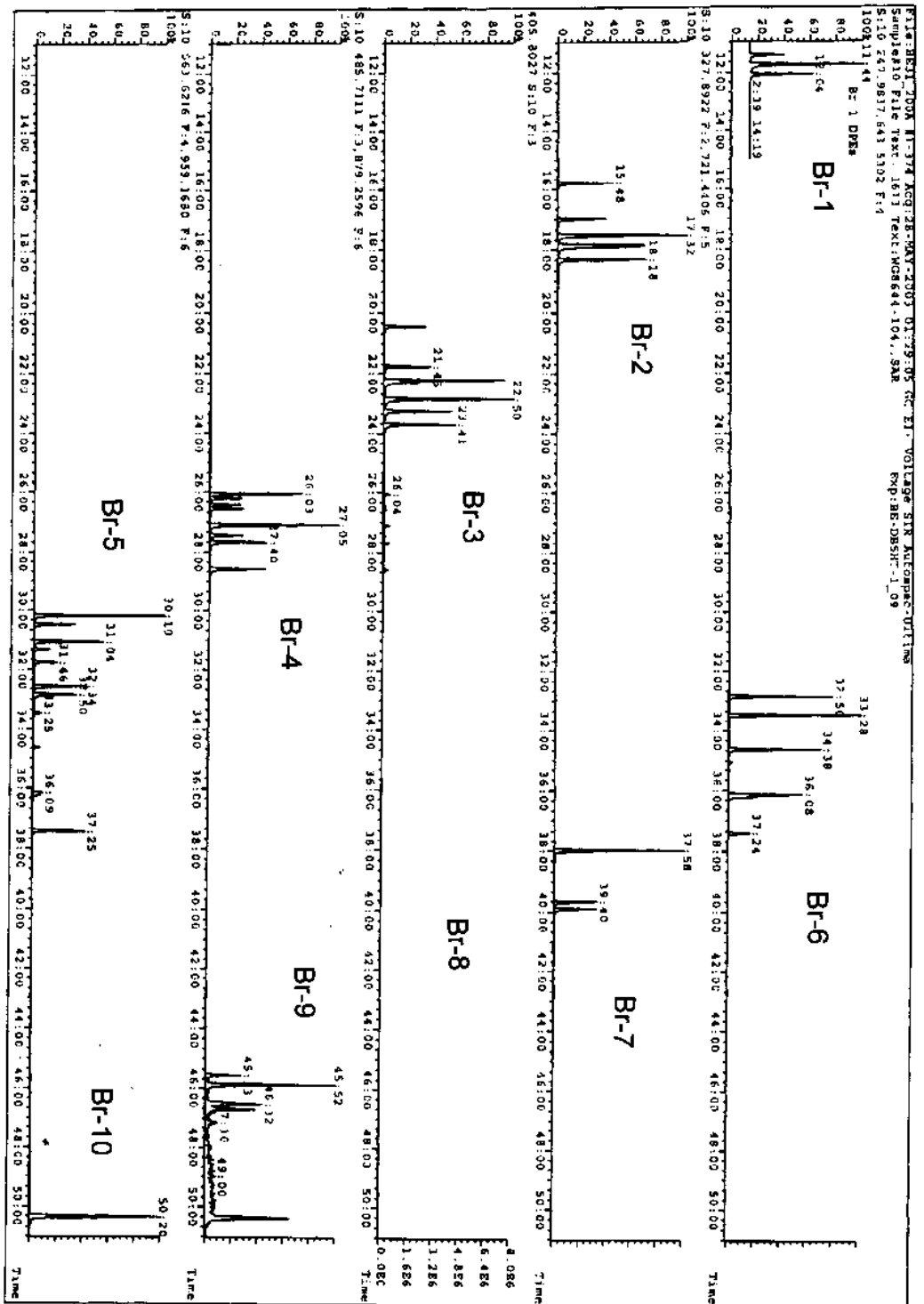

Figure 7 BDE congeners at each level of bromination on the DB-5HT column

24 Glossary of Definitions and Purposes

These definitions and purposes are specific to this Method but have been conformed to common usage to the extent possible.

24.1 Units of weight and measure and their abbreviations

24.1.1 Symbols

| | |
|----|-----------------|
| °C | degrees Celsius |
| μL | microliter |
| μm | micrometer |
| < | less than |
| > | greater than |
| % | percent |

24.1.2 Alphabetical abbreviations

| | |
|------|---|
| cm | centimeter |
| g | gram |
| h | hour |
| ID | inside diameter |
| in. | inch |
| L | liter |
| M | Molecular ion |
| m | meter |
| mg | milligram |
| min | minute |
| mL | milliliter |
| mm | millimeter |
| m/z | mass-to-charge ratio |
| N | normal; gram molecular weight of solute divided by hydrogen equivalent of solute, per liter of solution |
| OD | outside diameter |
| pg | picogram |
| ppb | part-per-billion |
| ppm | part-per-million |
| ppq | part-per-quadrillion |
| ppt | part-per-trillion |
| psig | pounds-per-square inch gauge |
| v/v | volume per unit volume |
| w/v | weight per unit volume |

24.2 Definitions and acronyms (in alphabetical order).

Analyte—A BDE tested for by this Method. The analytes are listed in Table 1.

Brominated diphenyl ether (BDE)—Any of the 209 congeners tested for by this Method and listed in Table 1.

Calibration standard (CAL)—A solution prepared from a secondary standard and/or stock solutions and used to calibrate the response of the HRGC/HRMS instrument.

Calibration verification standard (VER)—The mid-point calibration standard (CS-3) that is used to verify calibration. See Table 5.

CS-0.2, CS-1, CS-2, CS-3, CS-4, CS-5—See Calibration standards and Table 5.

DeBDE—decabromodiphenyl ether (BDE 209)

DiBDE—dibromodiphenyl ether

Field blank—An aliquot of reagent water or other reference matrix that is placed in a sample container in the laboratory or the field, and treated as a sample in all respects, including exposure to sampling site conditions, storage, preservation, and all analytical procedures. The purpose of the field blank is to determine if the field or sample transporting procedures and environments have contaminated the sample.

GC—Gas chromatograph or gas chromatography

GPC—Gel permeation chromatograph or gel permeation chromatography

HpBDE—heptabromodiphenyl ether

HRGC—High resolution GC

HRMS—High resolution MS

HxBDE—hexabromodiphenyl ether

Labeled injection internal standard—The $^{13}\text{C}_{12}$ -labeled PCB congeners spiked into the concentrated extract immediately prior to injection of an aliquot of the extract into the HRGC/HRMS. The labeled injection internal standards in this Method are PCBs with congener numbers 52L and 138L.

Internal standard—a labeled compound used as a reference for quantitation of other labeled compounds and for quantitation of native BDE congeners other than the congener for which it is a labeled analog. See Internal standard quantitation.

Internal standard quantitation—A means of determining the concentration of (1) a naturally occurring (native) compound by reference to a compound other than its labeled analog and (2) a labeled compound by reference to another labeled compound.

IPR—Initial precision and recovery—Four aliquots of a reference matrix spiked with the analytes of interest and labeled compounds and analyzed to establish the ability of the laboratory to generate acceptable precision and recovery. An IPR is performed prior to the first time this Method is used and any time the Method or instrumentation is modified.

Isotope dilution quantitation—A means of determining a naturally occurring (native) compound by reference to the same compound in which one or more atoms has been isotopically enriched. In this Method, all 12 carbon atoms in the BDE are enriched with carbon-13 to produce $^{13}\text{C}_{12}$ -labeled analogs of the brominated diphenyl ethers. The $^{13}\text{C}_{12}$ -labeled BDEs are spiked into each sample and allow identification and correction of the concentration of the native compounds in the analytical process.

K-D—Kuderna-Danish concentrator; a device used to concentrate the analytes in a solvent

Laboratory blank—See Method blank

Laboratory control sample (LCS)—See Ongoing precision and recovery standard (OPR)

Laboratory reagent blank—See Method blank

May—This action, activity, or procedural step is neither required nor prohibited.

May not—This action, activity, or procedural step is prohibited.

MDL—See Method Detection Limit

Method blank—An aliquot of reagent water or other reference matrix that is treated exactly as a sample including exposure to all glassware, equipment, solvents, reagents, internal standards, and surrogates that are used with samples. The method blank is used to determine if analytes or interferences are present in the laboratory environment, the reagents, or the apparatus.

Method Detection Limit—A detection limit determined by the procedure at 40 CFR 136, appendix B.

Minimum level of quantitation (ML)—The level at which the entire analytical system must give a recognizable signal and acceptable calibration point for the analyte. It is equivalent to the concentration of the lowest calibration standard, assuming that all Method-specified sample weights, volumes, and cleanup procedures have been employed (see 68 FR 11790; March 12, 2003).

MoBDE—monobromodiphenyl ether

MS—Mass spectrometer or mass spectrometry

Must—This action, activity, or procedural step is required.

NoBDE—nonabromodiphenyl ether

OcBDE—octabromodiphenyl ether

OPR—Ongoing precision and recovery standard (OPR; also laboratory control sample, LCS); an aliquot of reagent water or other reference matrix spiked with known quantities of the analytes. The OPR is analyzed exactly like a sample. Its purpose is to assure that the results produced by the laboratory remain within the limits specified in this Method for precision and recovery.

BDE—See brominated diphenyl ether.

Perfluorokerosene (PFK)—A mixture of compounds used to calibrate the exact m/z scale in the HRMS.

Polybrominated diphenyl ether (PBDE)—See Brominated diphenyl ether

Preparation blank—See Method blank

Quality control check sample (QCS)—A sample containing all or a subset of the analytes at known concentrations. The QCS is obtained from a source external to the laboratory or is prepared from a source of standards different from the source of calibration standards. It is used to check laboratory performance with test materials prepared external to the normal preparation process.

PeBDE—pentabromodiphenyl ether

Reagent water—water demonstrated to be free from the analytes of interest and potentially interfering substances at the method detection limit for the analyte.

Relative retention time (RRT)—The retention time of the component of interest divided by the retention time of its reference. The RRT references for the BDEs and labeled compounds are listed in Table 2.

Relative standard deviation (RSD)—The standard deviation times 100 divided by the mean. Also termed "coefficient of variation."

Retention time (RT)—The time between the time that an unretained component elutes and a component of interest elutes from a chromatographic column. Usually the time from the air peak or solvent front to the time at which the component of interest elutes, but also sometimes the time from the time of injection until the component of interest elutes. RTs for the BDEs on the DB-5HT column are listed in Table 2.

RF—Response factor. See Section 10.5

RR—Relative response. See Section 10.4

RRT—See Relative retention time

RSD—See Relative standard deviation

RT—See Retention time

SDS—Soxhlet/Dean-Stark extractor; an extraction device applied to the extraction of solid and semi-solid materials (Reference 10 and Figure 5).

Signal-to-noise ratio (S/N)—The height of the signal as measured from the mean (average) of the noise to the peak maximum divided by the width of the noise.

Should—This action, activity, or procedural step is suggested but not required.

SICP—Selected ion current profile; the line described by the signal at an exact m/z.

SPE—Solid-phase extraction; an extraction technique in which an analyte is extracted from an aqueous sample by passage over or through a material capable of reversibly adsorbing the analyte. Also termed liquid-solid extraction.

Specificity—the capability of an analytical system to identify and quantify an analyte when other analytes and interferences are present in the sample.

Stock solution—A solution containing an analyte that is prepared using a reference material traceable to EPA, the National Institute of Science and Technology (NIST), or a source that will attest to the purity and authenticity of the reference material.

TeBDE—tetrabromodiphenyl ether

TrBDE—tribromodiphenyl ether

Unique GC resolution or uniquely resolved—Two adjacent chromatographic peaks in which the height of the valley is less than 40 percent of the height of the shorter peak (See Section 6.9.1.1.2 and Figure 6 for unique resolution specific to the DB-5HT column).

VER—See Calibration verification.