

Now sold under the  
Thermo Scientific brand

**Thermo**  
SCIENTIFIC

# Determining Sub-ppb Perchlorate in Drinking Water Using Preconcentration/Matrix Elimination Ion Chromatography with Suppressed Conductivity Detection by U.S. EPA Method 314.1

## **INTRODUCTION**

Perchlorate is a well-known environmental contaminant. It has most often been associated with military defense and aerospace activities where it is used in the manufacture and testing of solid rocket propellants and missiles. Perchlorate has also been used in the private sector for the manufacture and development of pyrotechnics, air bag inflators, safety flares, and commercial explosives.<sup>1,2</sup> Industrial wastes resulting from the manufacture and disposal of this highly mobile and soluble anion have contaminated soils, surface waters, and groundwaters, where the contamination may persist for decades. Perchlorate has been found at nearly 400 sites across the United States, although most contaminated sites appear to be confined to the western states such as California, Arizona, New Mexico, and Nevada. Perchlorate has also been found in food products such as milk and lettuce.<sup>3</sup> Health studies have shown that perchlorate targets primarily the thyroid gland, which is responsible for extracting iodide from blood and converting it into organic iodide in the form of hormones that regulate metabolism.<sup>4</sup> The fetuses of expectant mothers may be particularly sensitive to the ingestion of perchlorate. The concentrations at which the perchlorate will demonstrate negative effects on the developing fetus, however, are still unknown.<sup>3</sup>

In 1998, the U.S. Environmental Protection Agency (EPA) placed perchlorate on its Candidate Contaminant

List for drinking water. Although there are currently no federal regulations for perchlorate, several states have adopted their own advisory levels. Concentrations established at the state level range from 1 ppb ( $\mu\text{g/L}$ ) to 18 ppb perchlorate. In 2004, the California Office of Environmental Health Hazard Assessment established a public health goal (PHG) of 6 ppb perchlorate.<sup>5</sup> However, a few states such as Maryland, Massachusetts, and New Mexico have set advisory levels for perchlorate at 1 ppb.

Perchlorate has commonly been determined using ion chromatography (IC) with suppressed conductivity detection as described in U.S. EPA Method 314.0. This method reports a method detection limit (MDL) of 0.53 ppb and a minimum reporting limit (MRL) of 4 ppb.<sup>6</sup> However, minor modifications to Method 314.0, such as the use of an improved suppressor that generates lower baseline noise and therefore a higher signal-to-noise ratio, coupled with the use of an electrolytically-generated potassium hydroxide eluent, results in a lower MRL of 1 ppb.<sup>7</sup> Regardless, Method 314.0 is subject to interferences and loss of sensitivity caused by the presence of high concentrations of the common matrix ions chloride, sulfate, and carbonate. In addition, some anionic compounds, such as chloro-benzene sulfonates, are known to elute at a similar retention time as perchlorate, and can therefore lead to a false positive. To avoid these complications, the EPA and Dionex Corporation collaboratively developed EPA Method 314.1, an improved IC method that uses precon-

centration/matrix elimination and suppressed conductivity detection.<sup>8</sup> This method uses an IonPac® Cryptand C1 preconcentration column to trap perchlorate from the matrix followed by matrix elimination with 10 mM sodium hydroxide. Perchlorate is then separated using a 2-mm IonPac AS16 as the primary column. To minimize the identification of a false positive peak, a second analytical column, the IonPac AS20, is used as the confirmatory column to verify the presence of perchlorate in the sample. The AS20 has a different selectivity than the AS16, and therefore provides an improved separation of perchlorate and potentially interfering anions such as chloro-benzene sulfonates. In this application note, we demonstrate the application of this method to the determination of trace (< 1 ppb) perchlorate in drinking water samples and a simulated high-ionic-strength matrix.

Although the method described herein is effective and should be used for compliance with EPA Method 314.1, Dionex recommends the method described in Application Note 178<sup>9</sup> for the determination of trace concentrations of perchlorate in high ionic strength matrices. The method in AN 178 was developed to support EPA Method 314.2, which had not been released at the time this note was published.

## EQUIPMENT

Dionex ICS-3000 Reagent-Free™ Ion Chromatography (RFIC™) system consisting of:

DP Dual Pump module

EG Eluent Generator module

DC Detector/Chromatography module  
(dual temperature zone configuration)

AS Autosampler with a 5-mL syringe (P/N 053915), 8.2 mL sampling needle assembly (P/N 061267) and sequential injection option (P/N 063294)

Two EluGen® EGC II NaOH cartridges (P/N 058908)

Two Continuously Regenerated Anion Trap Columns, CR-ATC (P/N 060477)

Four 4-L plastic bottle assemblies for external water mode of operation

Chromeleon® 6.7 Chromatography Workstation

## REAGENTS AND STANDARDS

Deionized water, Type I reagent grade, 18.2 MΩ-cm resistivity or better

Sodium Perchlorate (NaClO<sub>4</sub>) (Aldrich 41,024-1)

Sodium Chloride (NaCl) (J.T. Baker, VWR P/N JT3625-1)

Sodium Sulfate (Na<sub>2</sub>SO<sub>4</sub>) (Aldrich, 29,931-3)

Sodium Bicarbonate (NaHCO<sub>3</sub>) (EM Science, SX0320-1)

Sodium Hydroxide, 50% w/w (NaOH) (Fisher Scientific, SS254-1)

## CONDITIONS

Columns:	(A) Primary Method IonPac AS16 Analytical, 2 x 250 mm (P/N 055378) IonPac AG16 Guard, 2 x 50 mm (P/N 055379) (B) Confirmatory Method IonPac AS20 Analytical, 2 x 250 mm (P/N 063065) IonPac AG20 Guard, 2 x 50 mm (P/N 063066)
Eluent:	0.5 mM sodium hydroxide for 0–12 min, step at 12 min to 65 mM, 65 mM for 12–28 min, step at 28 min to 100 mM, 100 mM for 28–35 min*
Eluent Source:	ICS-3000 EG
Flow Rate:	0.25 mL/min
Temperature:	35 °C (lower compartment) 30 °C (upper compartment)
Inj. Volume:	2 mL
Rinse Volume:	1 mL (10 mM sodium hydroxide)
Concentrator:	IonPac Cryptand C1, 4 x 35 mm (P/N 062893)
Detection:	Suppressed conductivity, ASRS® ULTRA II (2 mm), AutoSuppression® external water mode Power setting—100 mA
SYSTEM:	
Backpressure:	Adjust to ~2400 psi
Background Conductance:	1–2 µS
Noise:	1–2 nS/min peak-to-peak
Run Time:	35 min

\*The columns should be allowed to equilibrate at 0.5 mM NaOH for 6 min prior to injection.

---

## **PREPARATION OF SOLUTIONS AND STANDARDS**

### **Stock Perchlorate Standard Solution**

Dissolve 0.1231 g sodium perchlorate in 100 mL of deionized water for a 1000 mg/L standard solution. When stored in an opaque, plastic storage bottle, this stock solution may be stable for up to one year.

### **Perchlorate Primary Dilution Standard**

Prepare 10 mg/L perchlorate solution by adding 1 mL of the 1000 mg/L stock standard in a 100-mL volumetric flask and dilute to volume with deionized water. When stored in an opaque plastic storage bottle, the resulting solution is stable for at least one month.

### **Perchlorate Secondary Dilution Standard**

Prepare a 1 mg/L perchlorate solution by adding 10 mL of the primary dilution solution to a 100-mL volumetric flask and dilute to volume with deionized water. When stored in an opaque, plastic storage bottle, the resulting solution is stable for at least one month.

### **Perchlorate Calibration Standards**

Prepare perchlorate calibration standards at 0.5, 1, 3, 5, and 10 µg/L by adding the appropriate volumes of the perchlorate secondary dilution solution to separate 100-mL volumetric flasks. Then add 2 mL of the primary common anion solution to each flask and dilute to volume with deionized water.

*Important: For the Cryptand C1 to effectively trap the perchlorate from the matrix, each standard must contain 100 mg/L each of chloride, sulfate, and bicarbonate by adding 2 mL of the primary common anion solution.*

### **Common Anion Stock Solutions**

Prepare 25 mg/mL (25,000 mg/L) each of chloride, sulfate, and bicarbonate as follows: Dissolve 4.121 g sodium chloride in deionized water and dilute to 100 mL; dissolve 3.696 g sodium sulfate in deionized water and dilute to 100 mL; dissolve 3.442 g sodium bicarbonate in deionized water and dilute to 100 mL.

### **Primary Common Anion Solution**

Prepare a combined common anion solution consisting of 5,000 mg/L each of chloride, sulfate, and bicarbonate by adding 20 mL of each common anion stock solution to a 100-mL volumetric flask and diluting to volume with deionized water.

### **Concentrator Rinse Solution**

Prepare 10 mM NaOH by adding 0.8 g of 50% w/w NaOH in ~800 mL of degassed deionized water in a 1-L volumetric flask and dilute to volume with deionized water.

*Important: Store this solution under helium in a pressurized vessel at all times when not in use to avoid the accumulation of carbonate. A rinse solution that is one week or older should be discarded.*

### **Sample Preparation**

All samples must be sterile-filtered with a 0.2-µm syringe filter (Corning 26 mm, surfactant-free cellulose acetate, Fisher 09-754-13) to remove any potential microorganisms. Perchlorate is susceptible to microbiological degradation by anaerobic bacteria.<sup>7</sup> A disposable sterile syringe (Henke Sass Wolf, 20-mL luer lock, Fisher 14-817-33) is used to draw up ~20 mL of the sample followed by attaching a sterile syringe filter. Discard the first 3-5 mL of sample, and then filter the remaining sample into a 125-mL sterile sample container (high density polyethylene, HDPE, I-Chem, Fisher N411-0125). Discard the syringe and filter after each use.

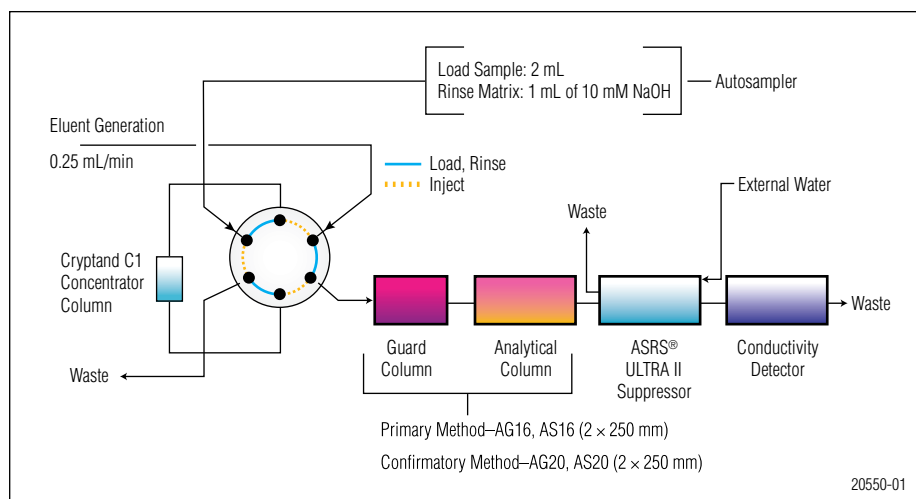

Figure 1. Schematic diagram of system configuration for U.S. EPA Method 314.1.

## SYSTEM PREPARATION AND SETUP

Install backpressure tubing in place of the columns on both system channels to produce a total backpressure of ~2000–2500 psi at a flow rate of 1 mL/min. Install an EGC II NaOH cartridge for each system channel. Condition the cartridges by setting the NaOH concentration to 50 mM at 1 mL/min for 30 min. After completing the condition process, disconnect this temporarily installed backpressure tubing. Install a CR-ATC between the EGC II NaOH cartridge and the EGC degas. Hydrate the CR-ATC prior to use by following the instructions outlined in the EluGen Cartridge Quickstart Guide (Document No. 065037-02). Figure 1 shows a schematic diagram of the system setup.

Install and configure the AS autosampler. The AS autosampler must be configured with the sequential injection option (P/N 063294) to simultaneously determine perchlorate on the primary and confirmatory columns. The AS concentration option allows the AS to deliver sample to a low-pressure concentrator at a maximum pressure of 100 psi. Therefore, a sample syringe speed no greater than 2 should be selected for this application. Because this application requires large sample injection volumes, a 5-mL sample syringe (P/N 053915) should be installed. To accommodate the larger volumes, an 8.2-mL sampling needle assembly (P/N 061267) is also required for operation.

To operate the AS autosampler in the concentrate + sequential injection mode, the injection port volume (including the needle seal tubing and the tubing from the diverter valve to the sample injection valve) must be calibrated to accurately deliver the designated volumes to the concentrator. Connect the AS injection port tub-

ing to the diverter valve and connect the diverter valve tubing to each injection valve. The diverter valve tubing must be the same length for each system. Calibrate the tubing volume for system #1 by performing the following procedure: 1) disconnect the diverter valve tubing from the sample injection valve of system #1; 2) press Menu, #5, #5, and select the SEQ + CONC sample mode; 3) press Menu, #8, #5 to go to the liquid control screen; 4) with the cursor in the Vial # field, press Select to change to INJ and press Enter; 5) select the following options (from: FLUSH, SYRINGE SPEED: 5, DIV VLV: 1 SYRINGE: SAMPLE, ASPIRATE: 1000  $\mu$ L, DISPENSE: 500  $\mu$ L); 6) change ACTION to ASPIRATE and press Enter to aspirate 1000  $\mu$ L into the sample syringe; 7) change ACTION to DISPENSE and press Enter to remove any potential air in the tubing; 8) select the following options (ASPIRATE: 500  $\mu$ L, from: NEEDLE); 9) change ACTION to ASPIRATE to remove all liquid from the tubing; 10) change VIAL to FLU and press Enter and change ACTION to EMPTY and press Enter; 11) select the following options (ASPIRATE: 2000  $\mu$ L, from: FLUSH, ACTION: ASPIRATE); 12) change VIAL to INJ and press Enter. Initially, a low DISPENSE volume should be selected (i.e., 50  $\mu$ L) and the SYRINGE SPEED should be set to 1. Change the ACTION to DISPENSE and press Enter.

Closely watch the end of the diverter tubing to observe if a small drop of liquid appears. If liquid appears from the tubing then the injection port volume must be recalibrated from the beginning. Otherwise, change DISPENSE to 1  $\mu$ L and press Enter. Set the cursor on ACTION and continue to press Enter until a small liquid drop appears.

## 4 An Improved Method for Determining Sub-ppb Perchlorate in Drinking Water Using Preconcentration/Matrix Elimination Ion Chromatography with Suppressed Conductivity Detection

---

*Important: Be aware of the total volume dispensed during this time (i.e., 50  $\mu$ L + the number of 1- $\mu$ L dispensings).*

After observing and verifying that a liquid is present at the end of the diverter tubing, record the injection port volume by going to menu, #5, #5. After completing this procedure, verify that the injection port volume for diverter valve 2 is approximately the same as diverter valve 1. The difference in volume between the diverter valves should be <2  $\mu$ L.

This application requires a matrix elimination step using 10 mM NaOH. There are two possible procedures for accomplishing this task:

- The best method for performing the rinse step is to use the sample prep syringe of the AS autosampler with a 5-mL syringe installed. In this setup, the hydroxide solution is always kept in a pressurized bottle under helium during sample analyses. However, the use of the sample prep syringe for rinsing the concentrator will require an additional 10 min per injection.
- An alternative is to fill a sample vial with 10 mM hydroxide and direct the autosampler to aspirate 1 mL from this vial for each injection. Because this vial is not stored under helium, it is strongly advised to change the hydroxide solution in the vial every day to maintain optimum performance of the method. In addition, separate rinse vials should be used for different standards and samples to minimize the potential for contamination of the rinse solution.

The advantage of using an AS vial for the rinse step is the reduced analysis time between injections compared to using the sample prep syringe. However, the disadvantages include potential carbonate contamination of the solution, the need for different rinse vials for different solutions, and the occupation of additional space in the autosampler tray.

Install an IonPac AG16 (2 x 50 mm) and an IonPac AS16 (2 x 250 mm) column on system #1 in the lower compartment of the DC. Install an IonPac AG20 (2 x 50 mm) and an IonPac AS20 (2 x 250 mm) column on system #2 in the lower compartment of the DC. Install an IonPac Cryptand C1 (4 x 35 mm) concentrator in place of the sample loop on the injection valves of each system. *Important: The sample loading and rinse steps must use the same direction of flow as the analytical column to allow perchlorate to refocus at the head of the guard column during the NaOH gradient.*

Make sure the pressure for both systems is approximately 2400 psi when 65 mM NaOH is delivered at 0.25 mL/min at a column temperature of 35 °C to allow the degas assembly to effectively remove electrolysis gases from the eluent. If necessary, install additional backpressure tubing between the degas assembly and the injection valve to achieve the recommended pressure setting. Because the pressure can gradually rise over time, monitor the pressure periodically. To reduce pressure, trim the backpressure tubing.

Hydrate the ASRS ULTRA II suppressor prior to installation by using a disposable plastic syringe and push 3 mL of degassed deionized water through the Eluent Out port and 5 mL of degassed deionized water through the Regen In port. To fully hydrate the suppressor screens and membranes, allow the suppressor to stand for approximately 20 min. Install the ASRS ULTRA II for use in the external water mode by connecting the Regen Out of the suppressor to the Regen In of the CR-ATC and the Regen In of the suppressor to the external water source. The Regen Out of the CR-ATC should be connected to the Regen In of the EG degasser.

Equilibrate the columns with 65 mM NaOH at 0.25 mL/min for at least 60 min prior to performing any injections. Analyze a matrix blank by injecting a solution consisting of 100 mg/L each of chloride, sulfate, and bicarbonate. There should be no peaks eluting within the same retention time window as perchlorate. Verify that the method is being performed correctly by approximating the signal height of the matrix peaks that typically begin to elute around 18 min. The maximum height of these peaks should be ~30–50  $\mu$ S. Inject a 5  $\mu$ g/L perchlorate standard. The peak area of this standard should be >0.080  $\mu$ S·min. Inject this standard on the system at least twice to verify that the peak areas and retention times are approximately the same. Inject a 0.5  $\mu$ g/L perchlorate standard. The response of this standard should be easily observed.

### **CHROMELEON PROGRAM**

Specific Chromeleon commands are required to allow the AS autosampler to concentrate the sample and rinse the matrix from the concentrator column. Therefore, an example program for Method 314.1 using the AS autosampler is shown in Appendix A.

## SYSTEM CALIBRATION

Calibrate the system by injecting one blank and five calibration standards to cover the desired concentration range. All blanks and standard solutions should contain 100 mg/L each of chloride, sulfate, and bicarbonate. The lowest concentration standard should be at or below the target minimum reporting level (MRL). The target MRL for this application was established at 0.5  $\mu\text{g/L}$  perchlorate. Tabulate the peak area response against the perchlorate concentration using the appropriate regression curve. EPA Method 314.1 allows the use of quadratic calibration curves in addition to the standard linear curve used for most applications.<sup>7</sup> The measured concentration for each calibration point, except the MRL, should be between 75 and 125% of its true value. The MRL should calculate to between 50 and 150% of its true value.

## RESULTS AND DISCUSSION

Table 1 summarizes the calibration data obtained by injecting calibration standards at 0.5, 1, 3, 5, and 10  $\mu\text{g/L}$ . A quadratic regression curve was used for both systems resulting in a correlation coefficient of 0.9999 for the primary and confirmatory columns. The accuracy of the calibration curve was verified by injecting a 5  $\mu\text{g/L}$  perchlorate standard. The calculated recoveries for this standard were 104.5 and 99.8% for the primary and confirmatory columns, respectively. These recoveries are well within the 75–125% specifications of the method. Figure 2 shows a chromatogram of 5  $\mu\text{g/L}$  perchlorate for the AS16 and AS20 columns obtained using the described method parameters.

The 0.5  $\mu\text{g/L}$  perchlorate MRL was confirmed by analyzing seven replicate injections of the standard. The mean concentration and standard deviation of the replicate analyses were then calculated for the replicates. The Half Range for the prediction interval of the results was calculated according to the equation in Section 9.2.4.1 in Method 314.1. This calculation produced results of 0.099 and 0.103  $\mu\text{g/L}$  for the AS16 and AS20 columns, respectively. These values were then used to determine the lower and upper limits for the Prediction Interval of Results (PIR) using the equations described in Section 9.2.4.2. The results from these calculations should produce values that are  $\pm 50\%$ . The lower limit PIR for the primary and confirmatory column was 77% and 73%, respectively. The upper limit PIR was 117% and 115% for the primary and confirmatory columns, respectively. Therefore, an MRL of 0.5  $\mu\text{g/L}$  was determined acceptable for this application because the

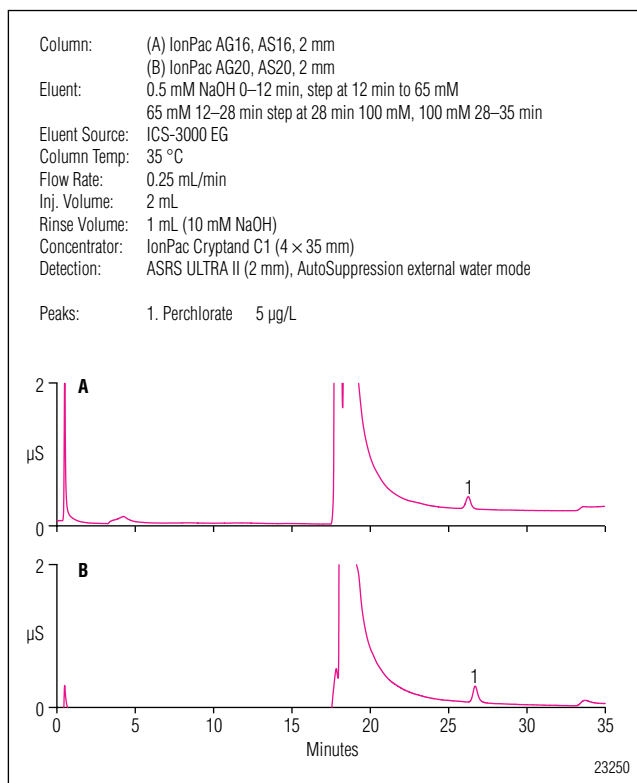

Figure 2. Chromatograms of a 5  $\mu\text{g/L}$  perchlorate standard separated on (A) IonPac AS16 and (B) IonPac AS20 columns.

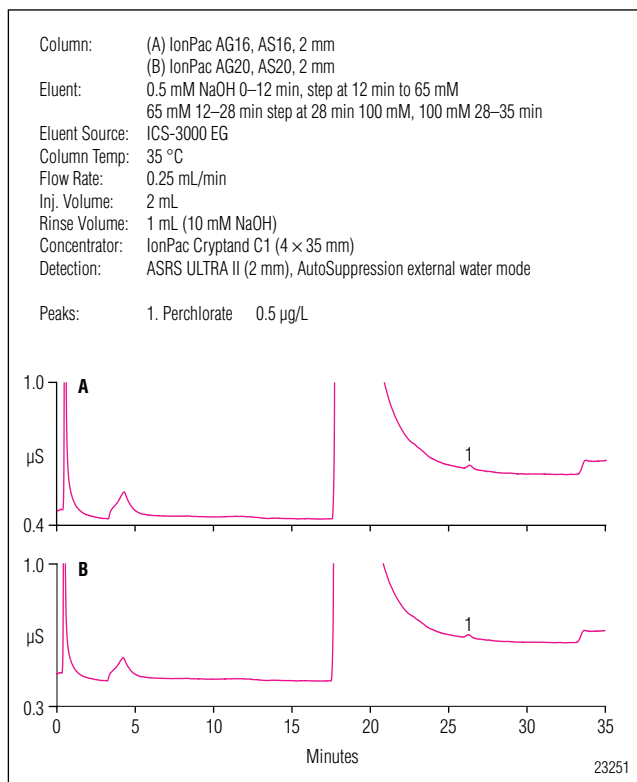

Figure 3. Chromatograms of a 0.5  $\mu\text{g/L}$  perchlorate standard separated on (A) IonPac AS16 and (B) IonPac AS20 columns.

lower and upper limit PIR were within the specifications of the method. Figure 3 shows a chromatogram of 0.5 µg/L perchlorate for the primary and confirmatory methods of EPA 314.1.

To demonstrate the accuracy and precision of the method, seven replicate injections of 5 µg/L perchlorate (mid-point calibration standard) were analyzed. The precision and recovery of the replicate injections were calculated as part of the initial demonstration of capability. Sections 9.2.2 and 9.2.3 specify that the %RSD and recovery of the replicate values should be ≤ 20% and ± 25% of the true values, respectively. The IonPac AS16 primary column produced a %RSD of 5.4% and an average recovery of 100.5%. The IonPac AS20 confirmatory column had a %RSD of 4.2% and a recovery of 91.2% for seven replicate injections of 5 µg/L perchlorate. The calculated values for both columns were well within the specifications of the method.

Although the determination of the detection limit of perchlorate is not a specific requirement of Method 314.1, some individual laboratories that are governed by various regulatory bodies may require this determination for compliance monitoring. Therefore, the perchlorate detection limit was determined for this application by fortifying deionized water with 0.1 µg/L perchlorate and performing seven replicate injections. For the Cryptand C1 concentrator to effectively trap perchlorate from the matrix, 100 mg/L each of chloride, sulfate, and bicarbonate must be included in the standard. The detection limits for the primary and confirmatory columns were calculated using the equation provided in Section 9.2.7. The calculated detection limits using Method 314.1 were comparable to those determined by IC-MS and about four times

**Table 1. Calibration Data and Method Detection Limits for Perchlorate**

Method	Analyte	Range (µg/L)	Linearity <sup>a</sup> (r <sup>2</sup> )	MDL Standard (µg/L)	SD (µg/L)	Calculated MDL <sup>b</sup> (µg/L)
Primary	Perchlorate	0.5–10	0.9999	0.1	0.007	0.023
Confirmatory	Perchlorate	0.5–10	0.9999	0.1	0.008	0.026

<sup>a</sup> Quadratic regression curve

<sup>b</sup> MDL =  $\sigma_{t_{99}}$ , where  $t_{t_{99}} = 3.14$  for  $n = 7$

lower than demonstrated in Application Update 148.<sup>2,8</sup> Table 1 summarizes the results of this calculation for each column.

A final demonstration of initial laboratory performance for EPA Method 314.1 is an MRL confirmation in a matrix consisting of 1000 mg/L each of chloride, sulfate, and bicarbonate. We fortified this matrix with 0.5 µg/L per-

chlorate and analyzed seven replicates using the primary and confirmatory methods. The criteria described in Section 9.2.4.2 were applied to this series of replicates. The results further demonstrated that 0.5 µg/L is an acceptable MRL to use for Method 314.1.

Samples containing high concentrations of common anions, in particular chloride, sulfate, and carbonate, are known to interfere with the determination of low concentrations of perchlorate. In EPA Method 314.0, the determination of the matrix conductivity threshold (MCT) was required to assess the maximum concentration of common anions that the column could tolerate before observing significant loss of sensitivity for perchlorate.<sup>6</sup> For samples that exceeded the MCT, a dilution or sample pretreatment using OnGuard® cartridges was required. However, sample dilution raises the MRL by an equivalent proportion whereas sample pretreatment can be a very time-consuming and tedious process. EPA Method 314.1 eliminates these procedures by using a Cryptand C1 concentrator column that retains perchlorate while most of the matrix ions are diverted to waste. Consequently, this allows the injection of larger sample volumes in high-ionic-strength matrices without loss of sensitivity for perchlorate. Figure 4 compares the injection of a 5 µg/L perchlorate standard with and without a rinse step using 10 mM NaOH. This comparison demonstrates

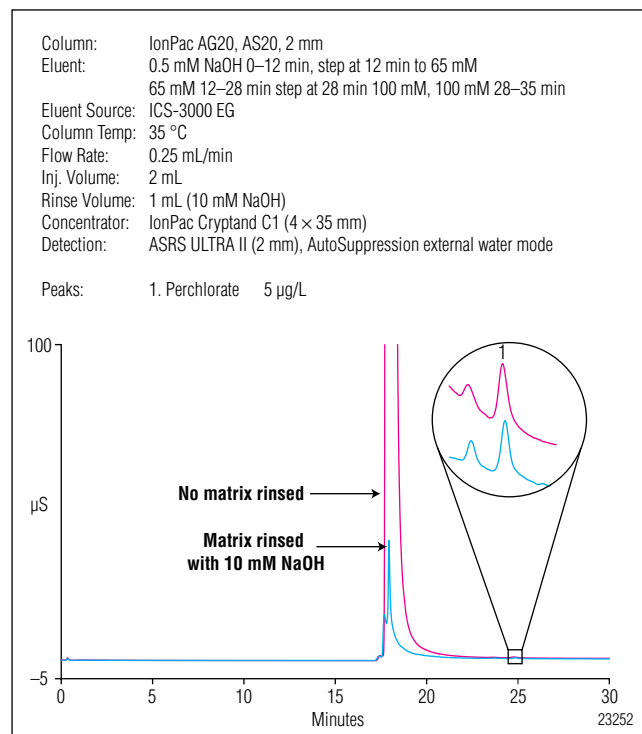

Figure 4. Comparison of a 5 µg/L perchlorate sample with and without a matrix rinse step.

that >90% of the 100 mg/L each of chloride, sulfate, and bicarbonate in the standard are diverted from the concentrator to waste, while the perchlorate is retained.

The ionic strength of drinking water matrices can vary considerably and therefore influence the integrity of the perchlorate results. To assess the performance of Method 314.1 for the determination of trace perchlorate, prepare and analyze a laboratory fortified sample matrix (LFSM). This is accomplished by adding a known quantity of perchlorate to the matrix and calculating the percent recovery of the amount added. This will determine whether the sample matrix contributes bias to the analytical results. For samples that produce a positive result for perchlorate on the primary column at or above the MRL should be verified with the confirmatory column. The recovery of perchlorate was assessed in six matrices: reagent water, four drinking waters from various sources, and a synthetic high-ionic-strength (HIW) matrix. Samples were fortified with 0.5 and 5 µg/L perchlorate. Some samples may require correction for native concentrations of perchlorate <MRL when the samples are fortified at or near the MRL. This is the only permitted use of analyte results <MRL according to Section 12.2.1 in Method 314.1. In addition, continuing calibration check standards were analyzed throughout each group of sample matrices to verify the accuracy of the calibration curve and integrity of the concentrator column during the field sample analyses. Low, mid, and high-level calibration check standards consisting of perchlorate concentrations of

0.5, 5, and 10 µg/L perchlorate, respectively, in 100 mg/L and 1000 mg/L each of chloride, sulfate, and bicarbonate were used.

Tables 2 and 3 summarize the performance of the method for determining trace concentrations of perchlorate in various matrices using the primary and confirmatory methods. For samples fortified with 0.5 µg/L perchlorate, recoveries ranged from 93 to 110% and 94 to 104% using the primary and confirmatory methods, respectively. These recoveries are well within the ±50% acceptance criteria of Method 314.1. For samples fortified with 5 µg/L perchlorate, recoveries ranged from 100 to 112% and 91 to 120%, respectively, which were within the ±25% criteria. The highest native perchlorate concentration was detected in drinking water C that contained approximately 1.9 µg/L perchlorate. However, this concentration was still about three times lower than the California Department of Health Service's PHG of 6 µg/L. Because this concentration is well above our 0.5 µg/L MRL, confirmation of the perchlorate result was required according to Section 11.3.4.2 in Method 314.1. The confirmatory IonPac AS20 column produced approximately the same perchlorate concentration. Fortification of this sample with 5 µg/L perchlorate resulted in calculated recoveries of 112.5% and 108.7% using the

Matrix	Amount Found (µg/L)	Amount Added (µg/L)	Replicates	Peak Area Precision (% RSD)	Average Recovery (%)
Reagent water	—	0.5	7	5.15	97.0
		5.0	7	5.40	100.5
HIW	—	0.5	7	4.24	93.3
		5.0	7	2.22	106.4
Drinking water A	0.096	0.5	7	3.30	106.6
		5.0	7	1.42	97.4
Drinking water B	0.289	0.5	7	3.40	98.8
		5.0	7	2.60	108.8
Drinking water C	1.87	0.5	7	0.76	110.0
		5.0	7	1.81	112.5
Drinking water D	<MDL	0.5	7	4.00	107.8
		5.0	7	2.24	112.0

Matrix	Amount Found (µg/L)	Amount Added (µg/L)	Replicates	Peak Area Precision (% RSD)	Average Recovery (%)
Reagent water	—	0.5	7	5.64	94.2
		5.0	7	4.21	91.2
HIW	—	0.5	7	4.10	95.7
		5.0	7	2.22	101.8
Drinking water A	NA <sup>1</sup>	0.5	7	NA	NA
		5.0	7	5.96	120.0
Drinking water B	0.182	0.5	7	2.28	103.8
		5.0	7	2.21	108.7
Drinking water C	1.92	0.5	7	1.43	95.2
		5.0	7	2.10	108.7
Drinking water D	NA	0.5	7	NA	NA
		5.0	7	4.95	107.3

<sup>1</sup> NA = not available due to a coeluting peak.



IonPac AS16 and AS20 columns, respectively. Figure 5 shows chromatograms of the unfortified and fortified drinking water C using the IonPac AS16 primary column.

The use of two analytical columns with different selectivities is extremely beneficial in determining whether perchlorate is truly present in the sample. Two of our drinking water samples highlighted the need for two column selectivities. Figure 6A shows a chromatogram of 0.5  $\mu\text{g/L}$  perchlorate fortified in drinking water A using the IonPac AS16 column. As shown, no additional peaks elute within the same retention time window as perchlorate. However, Figure 6B shows the same separation on the IonPac AS20. In this chromatogram, an unknown peak elutes at almost exactly the same time as perchlorate. A false positive result may have been reported if the separation on the IonPac AS16 had not confirmed the absence of perchlorate in the sample.

Figure 7 shows a second example of a potentially false positive perchlorate identification. This chromatogram shows a separation of drinking water D fortified with 0.5  $\mu\text{g/L}$  perchlorate using the primary column. As shown, there are several unidentified peaks observed. However, perchlorate is still well resolved from the unknown peaks. Figure 8A shows the chromatogram of the unfortified drinking water D. Figure 8B shows the chromatogram of the same sample fortified with 5  $\mu\text{g/L}$  perchlorate separated on the IonPac AS20. As the first chromatogram illustrates, several unknown peaks elute before the expected retention time of perchlorate and one unidentified peak elutes at approximately the same retention time as perchlorate. After fortification of the sample, the peak is split into two separate peaks that verify that the unknown peak is not perchlorate. This conclusion was further confirmed based on the previous results with the IonPac AS16 column (Figure 7).

The performance of this method can be improved by removing carbonate prior to detection using a Carbonate Removal Device (CRD). The CRD can produce lower baseline conductivity, reduce the slope from the matrix signal and, therefore, increase the sensitivity of the method for perchlorate. Although a CRD was not implemented for the data shown in Tables 2 and 3, we evaluated the benefits of this device for selected drinking water matrices. Figure 9 compares the separation of 0.5  $\mu\text{g/L}$  fortified in drinking water D with and without a CRD. As this figure illustrates, the baseline is dramatically reduced when the CRD is implemented into the system. In addition, a 10% increase in the perchlorate signal was observed with the CRD.

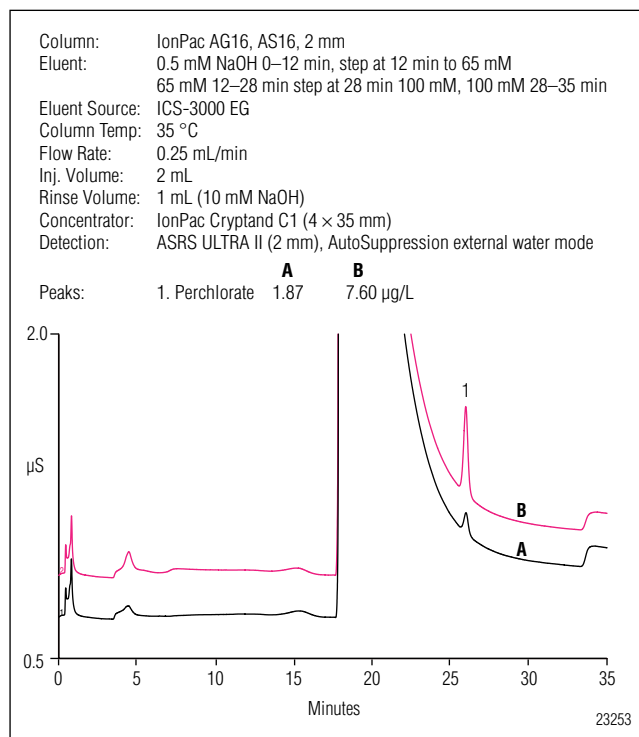

Figure 5. Chromatograms of (A) unfortified and (B) fortified drinking water C with 5  $\mu\text{g/L}$  perchlorate using the IonPac AS16 column.

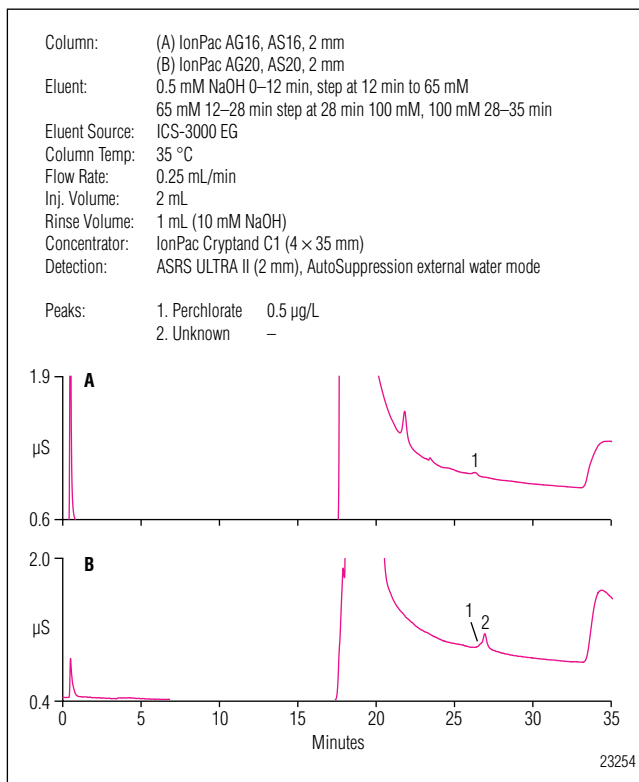

Figure 6. Chromatograms of drinking water A fortified with 0.5  $\mu\text{g/L}$  perchlorate using the (A) primary method and (B) confirmatory method.

## CONCLUSION

This application note demonstrates the ability to concentrate 2 mL of sample and eliminate most of the matrix ions using a dilute sodium hydroxide solution for trace perchlorate determinations as described in EPA Method 314.1. This method is a significant improvement to Method 314.0 for determining perchlorate in various drinking water matrices. The injection of larger sample volumes and elimination of the matrix ions resulted in an improved perchlorate detection limit of  $\sim 0.02 \mu\text{g/L}$  and a lower minimum reporting level of  $0.5 \mu\text{g/L}$ . In addition, Method 314.1 can tolerate higher-ionic-strength samples without sample dilution or pretreatment compared to Method 314.0. This can further simplify the sample analysis for most laboratories that are required to determine perchlorate for compliance monitoring. The sequential + concentrate feature of the AS autosampler automates all the sample loading and rinsing steps for both the primary and confirmatory methods. The eluent generator further simplifies the method by automatically producing the required NaOH eluent concentrations required for the method. The results presented in this application note meet all performance requirements specified in EPA Method 314.1.

## REFERENCES

1. Jackson, P. E., Gokhale, S., Streib, T., Rohrer, J. S., Pohl, C. A. Improved Method for the Determination of Trace Perchlorate in Ground and Drinking Waters by Ion Chromatography. *J. Chromatogr. A*, **2000**, 888, 151.
2. Hedrick, E., Munch, D. Measurement of Perchlorate in Water by Use of an  $^{18}\text{O}$ -Enriched Isotopic Standard and Ion Chromatography with Mass Spectrum Detection. *J. Chromatogr. A*, **2004**, 1039, 83.
3. *Perchlorate: A System to Track Sampling and Cleanup Results is Needed*. Document GAO-05-462, United States Government Accountability Office; Washington, D.C., May **2005**.
4. Urbansky, E. T. Review and Discussion of Perchlorate Chemistry as Related to Analysis and Remediation. *Bio-rem. J.* **1998**, 2, 81.
5. *Perchlorate in California Drinking Water: Overview and Links*. Updated January, **2006**, California Department of Health Services. [www.dhs.ca.gov/ps/ddwem/chemicals/perchl/perchlindex.htm](http://www.dhs.ca.gov/ps/ddwem/chemicals/perchl/perchlindex.htm).
6. *Determination of Perchlorate in Drinking Water Using Ion Chromatography*. Method 314.0; U.S. Environmental Protection Agency, Cincinnati, Ohio, **1999**.

## 10 An Improved Method for Determining Sub-ppb Perchlorate in Drinking Water Using Preconcentration/Matrix Elimination Ion Chromatography with Suppressed Conductivity Detection

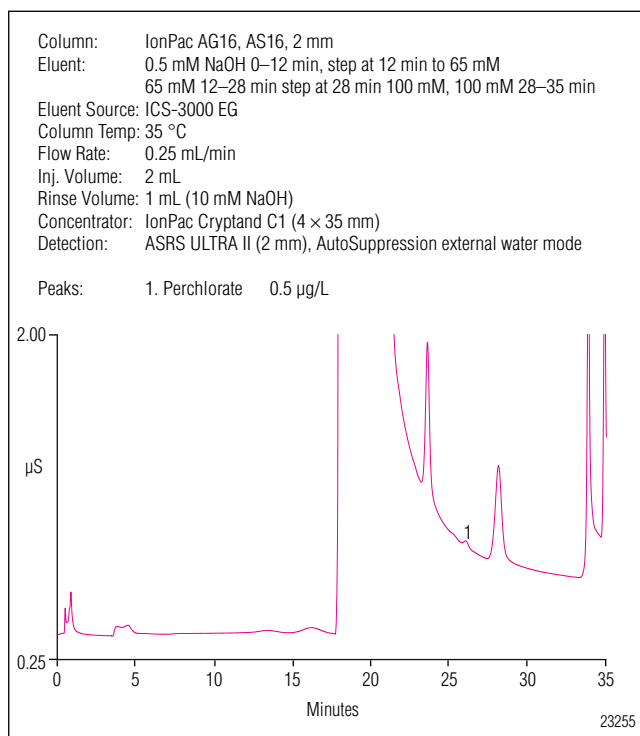

Figure 7. Chromatogram of drinking water D fortified with  $0.5 \mu\text{g/L}$  perchlorate using the primary method.

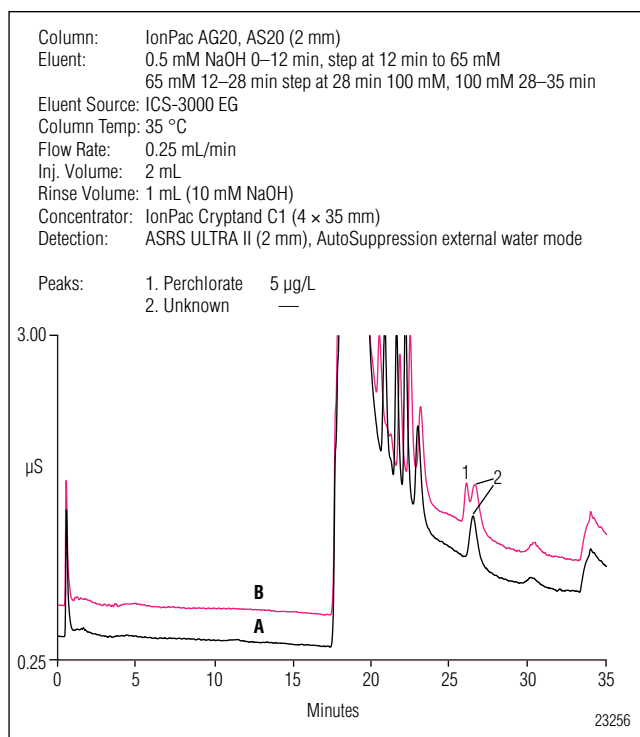

Figure 8. Chromatograms of (A) unfortified drinking water D and (B) fortified drinking water D using the confirmatory method.

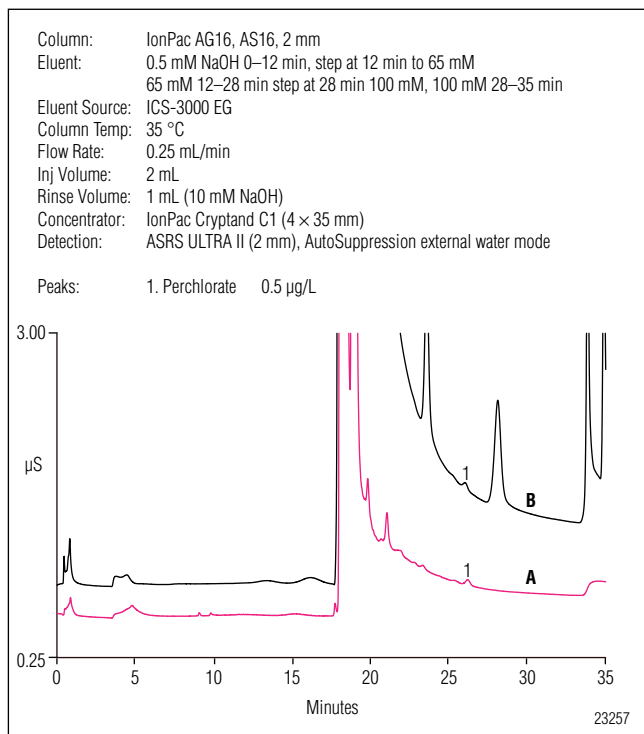

Figure 9. Comparison of drinking water D fortified with 0.5 µg/L perchlorate (A) with the CRD and (B) without the CRD using the primary method.

7. *Determination of Perchlorate in Drinking Water Using Reagent-Free Ion Chromatography.* Application Update 148, Dionex Corporation, Sunnyvale, CA.
8. *Determination of Perchlorate in Drinking Water Using In-Line Column Concentration/Matrix Elimination Ion Chromatography with Suppressed Conductivity Detection: Method 314.1.*; U.S. Environmental Protection Agency, Cincinnati, Ohio, **2005**.
9. *Improved Determination of Trace Concentrations of Perchlorate in Drinking Water Using Preconcentration with Two-Dimensional Ion Chromatography and Suppressed Conductivity Detection.* Application Note 178, Dionex Corporation, Sunnyvale, CA.

## APPENDIX A

### Example Chromeleon Program

```

Sampler.AcquireExclusiveAccess
Sampler_DiverterValve.Position_1
Column_TC.AcquireExclusiveAccess
Compartment_TC.AcquireExclusiveAccess
Pressure.LowerLimit = 200 [psi]
Pressure.UpperLimit = 3000 [psi]
MaximumFlowRamp = 6.00 [ml/min2]
%A.Equate = "%A"

```

```

%B.Equate = "%B"
%C.Equate = "%C"
%D.Equate = "%D"
CR_TC = On
Flush Volume = 4999
Wait FlushState
NeedleHeight = 2 [mm]
CutSegmentVolume = 0 [µl]
SyringeSpeed = 2
CycleTime = 0 [min]
WaitForTemperature = False
Data_Collection_Rate = 5.0 [Hz]
Temperature_Compensation = 1.7 [%/°C]
CellHeater.Mode = On
CellHeater.TemperatureSet = 35.00 [°C]
Column_TC.Mode = On
Column_TC.TemperatureSet = 35.00 [°C]
Compartment_TC.Mode = On
Compartment_TC.TemperatureSet = 30.00 [°C]
Suppressor1.Type = ASRS_2mm
CurrentSet = 100 [mA]
; Suppressor1.Carbonate = 0.0
; Suppressor1.Bicarbonate = 0.0
; Suppressor1.Hydroxide = 100.0
; Suppressor1.Tetraborate = 0.0
; Suppressor1.Other eluent = 0.0
; Suppressor1.Recommended Current = 62
Note: the following commands are used to concentrate
the sample and rinse the matrix from the concentrator
using the AS sample prep syringe (Option 1).
Concentrate ValvePosition = LoadPosition
ReagentPrime Volume = 20000.0, SourceReservoir =
Reservoir_C, ValvePosition = NoChange
ReagentFlush Volume = 1000.0, SourceVial = Reser-
voir_C, ValvePosition = NoChange
Note: the following commands are an alternative to Op-
tion 1 above by using an AS autosampler vial contain-
ing 10 mM NaOH to perform the rinse step (Option 2).
However, different programs will be required for differ-
ent "Sourcevials" (i.e., AS autosampler vials).
Concentrate ValvePosition = LoadPosition
ReagentFlush Volume = 1000.0, SourceVial = 37,
ValvePosition = NoChange

```

---

Wait SampleReady  
Flow = 0.250 [ml/min]  
%B = 0.0 [%]  
%C = 0.0 [%]  
%D = 0.0 [%]  
Pump\_1.Curve = 5  
-6.100 Concentration = 100.00 [mM]  
EGC\_1.Curve = 5  
-6.000 Concentration = 100.00 [mM]  
EGC\_1.Curve = 5  
Concentration = 0.50 [mM]  
EGC\_1.Curve = 5  
  
0.000 Wait CycleTimeState  
Sampler\_InjectValve.InjectPosition  
CD\_1.AcqOn  
CD\_1\_Total.AcqOn  
0.100 Home  
1.000 BeginOverlap  
Sampler.ReleaseExclusiveAccess  
12.000 Concentration = 0.50 [mM]  
EGC\_1.Curve = 5  
Concentration = 65.00 [mM]  
EGC\_1.Curve =  
28.000 Concentration = 65.00 [mM]  
EGC\_1.Curve = 5  
Concentration = 100.00 [mM]  
EGC\_1.Curve = 5  
35.000 CD\_1.AcqOff  
CD\_1\_Total.AcqOff  
Concentration = 100.00 [mM]  
EGC\_1.Curve = 5  
Compartment\_TC.ReleaseExclusiveAccess  
Column\_TC.ReleaseExclusiveAccess

ASRS, AutoSuppression, Chromeleon, EluGen, OnGuard and IonPac are registered trademarks and Reagent-Free and RFIC are trademarks of Dionex Corporation.

**Passion. Power. Productivity.**



**Dionex Corporation**

1228 Titan Way  
P.O. Box 3603  
Sunnyvale, CA  
94088-3603  
(408) 737-0700

**North America**

U.S. (847) 295-7500  
Canada (905) 844-9650

**South America**

Brazil (55) 11 3731 5140

**Europe**

Austria (43) 1 616 51 25 Benelux (31) 20 683 9768 (32) 3 353 4294  
Denmark (45) 36 36 90 90 France (33) 1 39 30 01 10 Germany (49) 6126 991 0  
Ireland (353) 1 885 1700 Italy (39) 02 51 62 1267 Switzerland (41) 62 205 9966  
United Kingdom (44) 1276 691722

**Asia Pacific**

Australia (61) 2 9420 5233 China (852) 2428 3282 India (91) 22 28475235  
Japan (81) 6 6885 1213 Korea (82) 2 2653 2580 Singapore (65) 6289 1190



[www.dionex.com](http://www.dionex.com)

LPN 1792-01 PDF 3/07  
© 2007 Dionex Corporation