

Now sold under the
Thermo Scientific brand

Thermo
SCIENTIFIC

Determination of Trace Anions in Concentrated Bases Using AutoNeutralization™ Pretreatment and Ion Chromatography

INTRODUCTION

The computer, semiconductor, and food industries need analytical methods to determine trace anions in concentrated bases. Anions at very low concentrations can cause corrosion, deposition defects, and electronic shorts in computer devices. In the food industry, sodium hydroxide and other caustic solutions used to remove the outer layers of fruit and vegetables¹ can affect taste. Other anions are toxic (bromate, oxalate, nitrate, and nitrite) or carcinogenic (nitrite and bromate) when ingested at high levels.

Ion chromatography (IC) with suppressed conductivity detection is the preferred method for determining ionic species, especially at $\mu\text{g/L}$ and ng/L concentrations. Direct injections of concentrated base samples result in high concentrations of the base anion that overload the column, resulting in poor chromatography and quantification. Therefore, concentrated bases must be diluted prior to anion analysis. However, this dilution sacrifices anion determinations at $\mu\text{g/L}$ and ng/L concentrations.

The introduction of AutoNeutralization by Dionex in 1994, embodied in the SP10 AutoNeutralization module, eliminated the need to dilute the concentrated base and thus allowed $\mu\text{g/L}$ and ng/L anion determinations.² This technique used multiple cycles through the neutralizer to completely neutralize the strong acid or base in the sample. The second embodiment of AutoNeutralization replaced the SP10 with two, six-port valves and an ex-

ternal pump installed on the ICS-2500 chromatography system. This method, reported in the previous version of this application note,³ effectively neutralized strong bases with a series of neutralizing cycles. This same technique was used to neutralize acids.⁴ In the latest version of AutoNeutralization, the sample was pumped into the ASRN™ II neutralizer by an external pump and trapped for a set period. This technique was coined *Park and AutoNeutralize*.⁵

Here we discuss neutralization with Park and AutoNeutralize using the ICS-3000 ion chromatography system with dual pumps, detectors, and valves. The system configurations, plumbing, valve operations, and program are described in this application note. The application includes the Carbonate Removal Device (CRD) to improve the determination of sulfate and other anions eluting near carbonate. The CRD removes carbonate from the sample prior to detection. The CRD and carbonate removal process are discussed thoroughly in Technical Note 62.⁶

This application note replaces the previous version of AN 93² and updates the method to use an IonPac® AS19 column set and an IonPac UTAC-XLP1 concentrator column. The IonPac AS19 is a high capacity, hydroxide-selective column (240 $\mu\text{eq/column}$) with selectivity for oxyhalides and inorganic anions. The AS19 contains a novel, hyper-branched anion-exchange condensation polymer attached to the 7.5 μm super ma-

macroporous resin. The IonPac UTAC-XLP1 (6 × 16 mm) concentrator column was selected for this application to ensure low sulfate blanks. The IonPac UTAC-XLP1 contains a latex agglomerated super macroporous resin and has a low void volume (<145 µL). It was designed for high purity water analysis. It is a latex agglomerated super macroporous resin. The IonPac UTAC-XLP1 column is similar to the older concentrator column, but to ensure minimal sulfate backgrounds, the resin is repeatedly carboxylated instead of sulfonated. Additionally, the new 6 × 16 mm configuration has the added benefit of very low backpressure.

This method successfully determined trace anions from low µg/L to low mg/L concentrations in 10% and 30% sodium hydroxide, 30% potassium hydroxide, and concentrated ammonium hydroxide (29% as NH₃, 59.7% as NH₄OH).

EXPERIMENTAL

Equipment

Dionex ICS-3000 Reagent-Free™ Ion Chromatography system with:

DC Detector/Chromatography module with Single Temperature zone, AM Automation Manager (P/N 079833), 10-port valve (P/N 061962), one injection valve, a standard bore temperature stabilizer, and two CD Conductivity Detector and Integrated Cells (P/N 079829)

DP Dual Pump module with Degas module, Gradient Mixer IonPac GM-4 (P/N 049136), and IonPac ATC-HC trap column (9 × 75 mm, P/N 059604)

EG Eluent Generator module with EluGen® II potassium hydroxide (Dionex P/N 058900), and Continuously Regenerating Anion Trap Column (CR-ATC, P/N 060477)

Dionex AS Autosampler with 10 mL sample tray and vial kit (P/N 055058), and 500 or 1000 µL sample syringe

Chromeleon® Chromatography Management system, Chromeleon 6.7

Tubing:

Black PEEK™ (0.25-mm or 0.01-in i.d., P/N 052306 for 5 ft) for liquid line connections for

both systems and backpressure loops for the ASRS® ULTRA II suppressor

Yellow PEEK (0.76-mm or 0.003-in i.d., P/N 052301 for 5 ft) for system backpressure loops
Green PEEK (0.76-mm or 0.30-in i.d., P/N 044077 per inch) for eluent waste lines

Low pressure Teflon® tubing (E.I. du Pont de Nemours, 1.6-mm or 0.063-in i.d., P/N 014157) for the CRD, external water regenerant lines for the ASRN II neutralizer, and ASRS ULTRA II suppressor regenerant and degas waste lines

100 µL sample loop (P/N 42951)

Suppressor External Regenerant Installation Kit (P/N 038018) for external water with one additional 4-L bottle

225-mL polystyrene sterile flasks for trace anion standards and samples (Corning P/N: 431081 or VWR P/N: 29186-199)

Reagents and Standards

Note: Use only ACS reagent grade chemicals for all reagents and standards.

Deionized water, type 1 reagent-grade, 18.2 MΩ-cm resistivity or better

Oxalic acid, dihydrate, crystalline (Fisher, P/N A219-500)

Sodium bromate (Sigma-Aldrich, P/N 224871)

Sodium bromide (Sigma-Aldrich, P/N 31,050-6)

Sodium chlorate (Sigma-Aldrich ReagentPlus™, P/N 24,414-7)

Sodium chloride, crystalline (JT Baker Ultrapure Bioreagent, P/N JT3624-1)

Sodium chlorite (Fisher, P/N LC236201)

Sodium fluoride (Fisher, P/N S299-100)

Sodium hydroxide solution, 50% (w/w) (Fisher Chemicals, P/N SS254-500)

Sodium nitrate, crystalline (Fisher, P/N S343-500)

Sodium nitrite (JT Baker, P/N JT3780-1)

Sodium phosphate, monobasic (EMD Biosciences Inc., P/N 80058-650)

Sodium sulfate, granular (EM Science, P/N EM-SX0760-1)

Samples

Sodium hydroxide, 10% and 30% (w/w) prepared from 50% (w/w) sodium hydroxide solution (Fisher Chemicals, P/N SS254-500)

Potassium hydroxide, 30% (w/w) from 45% (w/w) potassium hydroxide solution (JT Baker, P/N 3143-01)

Ammonium hydroxide, concentrated, 29% (w/w) as NH₃ (59.7% as NH₄OH), (Sigma, P/N 221228)

Conditions

Sample Preparation: System 2

Trap Column: IonPac ATC-HC, 9 × 75 mm

Flow Rate: 0.5 mL/min

Carrier: Degassed deionized water purified inline with a trap column

Inj. Volume: 100 µL (full-loop, calibrated value of 103 µL, which is the value used for all calculations in this application note)

Neutralization: ASRN II Anion Self-Regenerating Neutralizer (P/N 063433), external water mode, 495 mA

Run Time: 9.2 min for Park and AutoNeutralize and Concentrate

Typical

Backpressure: ~800 psi

Analytical: System 1

Columns: IonPac AG19, AS19 (4 × 50 mm, P/N 062887), (4 × 250 mm, P/N 062885)

Flow Rate: 1.0 mL/min

Eluent (EGC-KOH):

10 to 45 mM Potassium hydroxide from 10 to 25 min, 65 mM from 25 to 35 min

Column Temp.: 30 °C

Concentrator: IonPac UTAC-XLP1, 6 × 16 mm (P/N 063459)

CRD: 4-mm CRD (P/N 062983) installed between suppressor and the detector

Detection: Suppressed Conductivity, ASRS ULTRA II Anion Self-Regenerating Suppressor, recycle mode, 161 mA

Typical

Background: <1 µS

Typical

Backpressure: ~2200 psi

Typical Noise: <3 nS

Run Time: 35 min

Preparation of Solutions and Reagents

Preparation

It is essential to use high quality, Type 1 water, 18.2 MΩ-cm. It should contain as little dissolved carbon dioxide as possible.

Standard Preparation

To prepare individual stock solutions of 1000 mg/L fluoride, chloride, chlorite, bromate, nitrite, bromide, nitrate, sulfate, oxalate, and phosphate, weigh the amount of reagent grade compound (Table 1) in a 125 mL HDPE sample bottle and dilute with deionized water to 100.00 g total weight. Shake each stock solution to fully dissolve the reagent.

Table 1. Amount of Compound Used to Prepare 100 mL of 1000 mg/L Individual Stock Solutions

Anion	Compound	Mass (g)
Fluoride	Sodium fluoride (NaF)	0.221
Chlorite	Sodium chlorite (NaClO ₂)	0.134
Bromate	Sodium bromate (NaBrO ₃)	0.180
Chloride	Sodium chloride (NaCl)	0.165
Nitrite	Sodium nitrite (NaNO ₂)	0.150
Chlorate	Sodium chlorate (NaClO ₃)	0.128
Bromide	Sodium bromide (NaBr)	0.129
Nitrate	Sodium nitrate (NaNO ₃)	0.137
Sulfate	Sodium sulfate (Na ₂ SO ₄)	0.148
Oxalate	Oxalic acid dihydrate (HOCCOOH•2H ₂ O)	0.143
Phosphate	Sodium phosphate, monobasic (NaH ₂ PO ₄)	0.124

Table 2. Amount (μL) of 10 mg/L Intermediate Standards Used to Prepare 100 mL Working Standards of Fluoride, Chlorite, Bromide, Chlorate, Bromate, Oxalate, Phosphate, Nitrite, and Nitrate^a

10 mg/L Intermediate standards	Working Standards								
	1	2	3	4	5	6	7	8	9
Fluoride, chlorite, bromide, and chlorate	50	100	200	500	800	1200	2000	—	—
Bromate, oxalate, and phosphate	100	200	500	800	1200	2400	4000	—	—
Nitrite					1200	2000	2400	3000	4000
Nitrate	50	100	200	500	800	1200	2000	3000	4000

^a Combined working standards of 100, 500, 1000, 1500, 2000, 2500, 3000, and 3500 $\mu\text{g/L}$ chloride and sulfate were prepared from 1000 mg/L stock standards.

Intermediate and Working Standards

To determine anions in sodium and potassium hydroxide reagent samples, prepare separate 10.0 mg/L intermediate standards from fluoride, chlorite, bromate, nitrite, chlorate, bromide, nitrate, oxalate, and phosphate stock solutions in water. Pipette 1000 μL each of the 1000 mg/L individual stock solutions into separate 120 mL polypropylene bottles. Dilute with deionized water to 100.00 g total weight.

Prepare the Corning 225-mL polystyrene sterile flasks for the $\mu\text{g/L}$ standards two days or more prior to the standard preparation. Rinse each flask five times with deionized water, fill it to the top with deionized water, and let it soak overnight. Repeat this daily until flasks are needed for the $\mu\text{g/L}$ standards. (See Application Update 142 for additional precautions needed for determination of $\mu\text{g/L}$ anion concentrations.⁷)

To prepare working standards 1–4 (5, 10, 20, and 50 $\mu\text{g/L}$ fluoride, chlorite, bromide, chlorate, and nitrate, and 10, 20, 50, and 80 $\mu\text{g/L}$ bromate, oxalate, and phosphate), pipette the amounts in Table 2 into four 225-mL polystyrene sterile flasks. Dilute these working standards with deionized water to 100.00 g total weight and mix thoroughly. Prepare working standards 5–7 (80, 120, and 200 $\mu\text{g/L}$ fluoride, chlorite, bromide, chlorate and nitrate, 120, 200, and 240 $\mu\text{g/L}$ nitrite, and 120, 240, and 400 $\mu\text{g/L}$ bromate, oxalate, and phosphate) and working standards 8–9 (300 and 400 $\mu\text{g/L}$ nitrite and nitrate) in a similar manner. Prepare 100, 500, 1000, 1500, 2000, 2500, 3000, and 3500 $\mu\text{g/L}$ working standards of chloride and sulfate, similarly with 10, 50, 100, 150, 200, 250, 300, and 350 μL of 1000 mg/L stock standards of

chloride and sulfate. These standards can be prepared in 120 mL polypropylene bottles. Prepare low $\mu\text{g/L}$ standards daily, higher $\mu\text{g/L}$ standards weekly, and mg/L standards monthly.

Sample Preparation

To prepare samples of 10% (w/w) and 30% (w/w) (2.5 M and 7.5 M) of sodium hydroxide solution from 50% (w/w) (12.5 M) sodium hydroxide and degassed deionized water, first clean a 25-mL transfer pipette by rinsing it three times with deionized water. Shake out the excess liquid. Also clean a 225-mL polystyrene flask as described in the standard preparation section. To prepare the 10% (w/w) and 30% (w/w) sodium hydroxide sample, transfer 50.0 g and 150.0 g, respectively, of 50% sodium hydroxide with the pre-rinsed transfer pipette into a pre-cleaned 225-mL polystyrene flask containing 50.0 g of degassed deionized water. Dilute with degassed deionized water to 250.0 g total weight. Cap the bottle and gently shake bottle until the solution is thoroughly mixed. Prepare the 30% (w/w) potassium hydroxide solution in a similar manner with 166.7 g of 45% (w/w) potassium hydroxide in deionized water to 250.0 g total weight.

The concentrated (29% as NH_3 , 59.7% ammonium hydroxide) ammonium hydroxide solution was analyzed directly without dilution.

The Autoneutralization pretreatment method is recommended for concentrated bases up to 30%. Concentrated bases above 30% have higher viscosities that can cause longer loading times and result in lower reproducibilities.

Spike Recovery Samples in Water and Reagents

To prepare spike recovery samples in sodium hydroxide and potassium hydroxide solutions, the 1000 mg/L stock standards should be spiked directly into the water diluent. For example, to prepare spike recovery samples in 10% sodium hydroxide, pipette 10 μL of 1000 mg/L stock standards of bromate, chlorate, bromide, nitrate, and oxalate into a 225-mL pre-cleaned polystyrene flask containing 50.00 g of degassed deionized water. Also, pipette 20 μL of 1000 mg/L stock standard of phosphate, and 60 μL of 1000 mg/L stock standards of chloride and sulfate. Using a pre-rinsed 25-mL transfer pipette, fill the pipette with 50% sodium hydroxide and dispense it into the flask. Fill the pipette a second time and dispense until 40.00 g of 50% sodium hydroxide are added to the flask. Add degassed deionized water to a total weight of 200.00 g. Cap the flask and gently shake the flask until it is thoroughly mixed. The final concentrations are 50 $\mu\text{g/L}$ bromate, chlorate, bromide, nitrate, and oxalate, 100 $\mu\text{g/L}$ phosphate, and 300 $\mu\text{g/L}$ chloride and sulfate. Prepare the spike recovery samples for 30% sodium hydroxide and 30% potassium hydroxide and in a similar manner.

To prepare 200 $\mu\text{g/L}$ chloride, nitrite, and sulfate, and 40 $\mu\text{g/L}$ bromide, and 90 $\mu\text{g/L}$ of nitrate and oxalate spiked into concentrated ammonium hydroxide, pipette 40, 8, and 18 μL respectively, of 1000 mg/L stock standards into a pre-cleaned 225-mL polystyrene flask. Add concentrated ammonium hydroxide to a total weight of 200.00 g.

Anion Self-Regenerating Neutralizer ASRN II Operation

The AutoNeutralization pretreatment is based on the neutralization of the strong base to low conductivity water through the high capacity, electrolytic Anion Self-Regenerating Neutralizer (ASRN II) device. The ASRN II device neutralizes the strong base by exchanging the cation of the base with hydronium that is electrolytically generated. The neutralized sample is predominantly water with trace levels of anions. The neutralization process is thoroughly discussed in the ASRN II product manual.⁸

The Park and AutoNeutralization pretreatment includes two steps. First, the sample slug is routed through the eluent channel of the ASRN II and the flow of the carrier stream is diverted to place the sample slug within the eluent channel. This is called Park. Second, the sample slug is neutralized completely, then routed to a concentrator column for pre-concentration and analysis.

System Setup

The setup for the individual modules, components, and system are thoroughly described in the Operator's and Installation manuals^{9,10} for the ICS-3000 Chromatography system, and the Chromeleon Help menus.

The sample loading and neutralization by the Anion Self-Regenerating Neutralizer ASRN II occurs on System 2. The remaining trace anions in the neutralized sample are concentrated, injected, separated, and detected by suppressed conductivity on System 1.

System 2, Sample Preparation

Sample preparation for the Park and AutoNeutralization application uses the AS Autosampler, Pump 2 with IonPac ATC-HC (9 \times 24 mm) trap column, Automation Manager (AM) with a 10-port, high pressure valve (AM-HP1), Conductivity Detector CD 2, and the ASRN II neutralizer.

To set up System 2, connect black PEEK (0.254-mm or 0.010-in I.D.) tubing from Pump 2 to the IonPac ATC-HC trap column¹¹ and from the trap column to the inside of the DC. Add a 30-cm (12 in) length of yellow (0.076-mm or 0.003-in i.d.) PEEK tubing to make an approximately 800 psi backpressure loop. After priming Pump 2, verify that the System 2 pressure is between 800 and 900 psi. Remove or add yellow PEEK backpressure tubing to adjust the system pressure to 800–900 psi. Flush the ATC-HC trap column with deionized water for 20 min.

Open the upper chamber door of the ICS-3000 DC module and locate the Automation Manager and the AM-HP1 10-port high pressure valve 1, (top left corner of the Automation Manager). Plumb System 2 with black PEEK tubing according to Figure 1. Add black PEEK tubing from the yellow backpressure tubing to Port 1 on AM-HP1. Install the 100- μL loop (~49 cm of orange PEEK tubing) in Ports 2 and 4. Connect a 6.5 to 7 cm (2.6 to 2.8 in) piece of black PEEK tubing from Port 3 to Port 7 to connect the sample load side of the valve (Ports 1–5) to the neutralization side of the valve (Ports 6–10). Connect the AS Autosampler pink injection line tubing into Port 5. Connect one end of green (0.76-mm or 0.30-in i.d.) PEEK tubing into Port 6 and direct the other end into the waste container. Connect 35 to 37 cm (13.8 to 14.6 in) of black PEEK tubing from Port 10 to the inlet of CD 2 Conductivity Detector.

Set-up for the ASRN II Neutralizer

Hydrate the ASRN II neutralizer for 20 min, according to the QuickStart procedure in the neutralizer product manual.¹² Install the neutralizer in the suppressor slot for System 2. Connect a 21.0 to 23.0 cm (8.3 to 9.0 in) length of black PEEK tubing from Port 8 of the AM-HP1 valve to Eluent In on ASRN II neutralizer and a 44 to 46 cm (17.3 to 18.1 in) length of tubing from Eluent Out to Port 9. Install the external water regenerant on the neutralizer using the Suppressor External Regenerant Installation Kit. Connect Teflon tubing (1.6-mm or 0.063-in i.d.) to the Regen In port of the ASRN II neutralizer and from Regen Out to waste. Adjust the flow rate to 3-5 mL/min by adjusting the pressure on the external water regenerant system. To determine the flow rate, collect the water from the neutralizer into a 25-mL graduated cylinder for 5 min. The total volume should be 15 to 25 mL.

It is critical that the external water regenerant is flowing through the ASRN II neutralizer before the pump and the neutralizer are turned on. When the pump is turned off, the regenerant should also be turned off. It is also critical that the backpressure to the ASRN II neutralizer is less than 100 psi. Measure the backpressure on the neutralizer channel by disconnecting the line out of the eluent out port of the ASRN II (B). Replace the line and measure the system pressure with the line in (A). The difference “A minus B” should be less than 100 psi.

To reduce background sulfate contamination, install a temporary waste line from the CD 2 detector outlet and flush System 2 with deionized water overnight or until the background conductivity is $<2 \mu\text{S}$. Open the DC chamber and verify by sight that the external water is flowing through neutralizer before turning on the pump. To turn on the neutralizer, select the Detector Compartment tab (System 2) in the Chromeleon Panel (Default Panel Tabset), select SRS as the suppressor type, and enter 495 mA for the current. After the background conductivity is $<2 \mu\text{S}$, remove the temporary waste line on the CD 2 outlet and install 18 to 20 cm (7.1 to 7.9 in) of black PEEK tubing from the CD 2 outlet to the Port 5 (S) in the Inj. Valve 1 located in lower chamber of the DC. System 2 is now connected to System 1.

AS Autosampler Setup

On the AS Autosampler module, enter the sample loop volume of 100 μL or the calibrated volume and press the Enter key (Plumbing Parameters under Module Setup Menu). Also verify that the Sample Syringe Volume and the Prep Syringe Volumes are correct. For this application, use a 500 μL or 1000 μL sample syringe. For samples with extreme concentration differences, adjust the cut volume to 15 μL (Module Setup Menu under System Parameters). The Autosampler should also be in Normal mode (Use the _ key to select Normal for the Sample Mode. Press Enter.) Set the Flush and Prime volumes on the Chromeleon Panel. Enter 300 μL (or 3 times the sample loop) for the Flush volume and enter a large volume for the Prime volume (5000 μL). The injection volume, entered on the Sequence, is the same as sample loop volume. The volume removed from the vial is four times the injection volume. More information can be found in the AS Autosampler operator's manual.¹³

System 1, Analytical

System 1 analyzes the neutralized sample and includes Pump 1, eluent generation (EG 1 with degas and CR-ATC), injection (Inj. Valve 1), and concentration (IonPac Trace Anion Concentrator column, UTAC-XLPI, 6 \times 16 mm), separation (IonPac AS19, 4 \times 250 mm column and guard, 4 \times 50 mm), and suppressed conductivity detection (ASRS ULTRA II suppressor with CRD). The neutralized sample is moved from the ASRN neutralizer onto the conductivity detector in System 2 (CD 2) through Inj. Valve 1 in the DC, and onto the concentrator column. Then the concentrated neutralized sample is moved from the concentrator column into the IonPac AS19 column set.

To set up System 1, install the gradient mixer (GM-4), EGC II KOH cartridge, IonPac CR-ATC, ASRS ULTRA II suppressor, CRD, columns, and backpressure loops for the suppressor and the eluent generator. Connect black PEEK (0.254-mm or 0.010-in I.D.) tubing from Pump 1 to the gradient mixer (GM-4) and from the gradient mixer into the EG module. Install and condition the EluGen II KOH cartridge, hydrate and flush the CR-ATC, and install a backpressure loop

according to the start up instructions in the ICS-3000 operator's manual.¹⁴ Install the CR-ATC after the cartridge and before the degas module and the Port 2 P of Inj. Valve 1. Install a backpressure loop after the CR-ATC and before Port 2 P of Inj. Valve 1 (Figure 1). Install the IonPac UTAC-XLP1 concentrator column in Ports 1 L and 4 L according to the product manual instructions.¹⁵ Position the concentrator column closer to Port 4 than Port 1 and install it with a minimal amount of black PEEK tubing from the column outlet to Port 4 L. Connect the inlet of the concentrator column to Port 1 L. The sample is loaded and injected from Port 4 L. Install one end of the black PEEK tubing from the temperature stabilizer 1 into Port 3 C. Install the other end into the guard and analytical columns following the instructions in their product manuals.¹⁶ Connect green PEEK tubing into Port 6 W and direct the other end to waste.

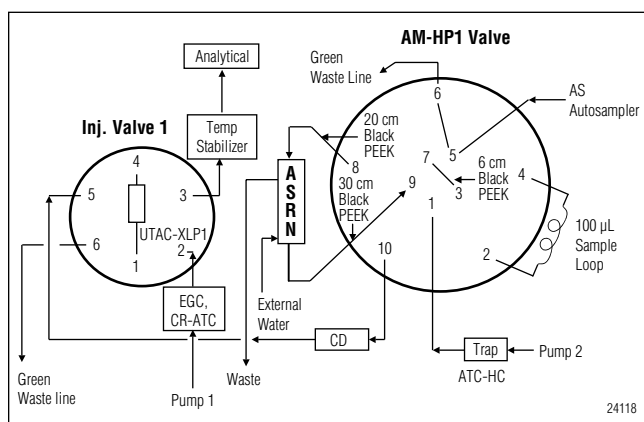

Figure 1. Valve configuration.

Before installing the backpressure loop on the cell, measure the backpressure directly from the pump to the cell. Install the backpressure loop on the “cell out” position of the conductivity cell and measure the backpressure. The difference of these two measurements is the backpressure due to the cell and backpressure loop. It must be between 30 and 40 psi to prevent suppressor damage. Follow the QuickStart instructions for the ASRS ULTRA II suppressor and the 4-mm CRD to hydrate and install them.^{17,18} Install the suppressor in recycle mode in the System 1 suppressor slot between the columns and the CD 1. Install the CRD on the suppressor. Tighten the fitting to finger-tight. Do not over-

tighten

the fittings on the CRD. Set the Pump 1 flow rate to 1.0 mL/min and prime the pump. Adjust the system pressure to about 2200 psi by adding or removing yellow PEEK tubing to the system backpressure loop.

Configuration

Using the Chromeleon Server Configuration program, create one timebase and add the ICS-3000 modules and AS Autosampler.¹⁰ Under DC Properties, assign the ASRS ULTRA II suppressor to System 1 and ASRN II neutralizer to System 2. Rename the ASRN II neutralizer as Neutralizer, for convenience and clarity. This application uses two high-pressure valves (AM-HP1 and Inj. Valve 1). Verify that the boxes in front of AM-HP1 and Inj. Valve 1 are checked, and that no other valves are checked. Assign control of the AM-HP1 valve to the AS Autosampler, and control of the Inj. Valve 1 to the DC. Verify that the EGC II cartridge is listed on System 1 and that it is linked to Pump 1. Under the AS Autosampler properties, verify that Sample Overlap box is checked. Sample Overlap reduces the total sample analysis time.

Creating the Program

Use Chromeleon Wizard, the eluent conditions (Table 3), and valve commands (Table 4) to create a program for Park and AutoNeutralization. The eluent conditions are programmed to wash the column before returning to the initial conditions for the next run. The eluent concentration remains at 65 mM potassium hydroxide from the end of the last program to the beginning of the 10 mM potassium hydroxide equilibrium

Table 3. Chromeleon Entries for Eluent Conditions		
Time (min)	Potassium Hydroxide Concentration (mM)	Description
0	65	Continue column wash
3.9	10	Start 4.3 min equilibration
4.0	10	Equilibration (3.9–9.2 min) and initial conditions (9.2–19 min)
19.0	10	Start gradient
34.0	45	End gradient
34.1	65	Start column wash
45.0	65	Column wash

Table 4. Chromeleon Wizard Valve Commands to Control Inj. Valve and the AM-HP1 Valves

Time (min)	Valve	Position	Action
0.2	AM-HP1	A	The sample is isolated onto ASRN II and neutralized.
8.1	Inj. Valve 1	Load	Inj. Valve 1 (System 1) is turned to Load.
8.2	AM-HP1	B	The neutralized sample is released from the neutralizer. Start concentrating the sample onto the UTAC-XLP1 concentrator column.
9.2	Inj. Valve 1	Inject	Inject neutralized, concentrated sample into analytical system.

(3.9 min). During this period, the sample is loaded and partially neutralized.

To enter the suppressor type for the ASRN II neutralizer, select SRS-MPIC. Set the current at the maximum level (495 mA). The ASRS ULTRA II, 4-mm is listed under suppressor types. Select it and set the current for 161 mA.

Enter the valve commands for Inj. Valve and the AM-HP1 valves in the Relay & State Devices Option section.

In the program review mode, verify the valve timing and the gradient timing. Remove any *Duration=number* on the valve commands. Save the program.

RESULTS AND DISCUSSION

This application uses both systems on the ICS-3000 Ion Chromatography system. Before discussing the experiments, it is helpful to review the flow path of the AM-HP1 valve. The valve has two states: A and B. In sample load (Figure 2), the valve is in state A. The

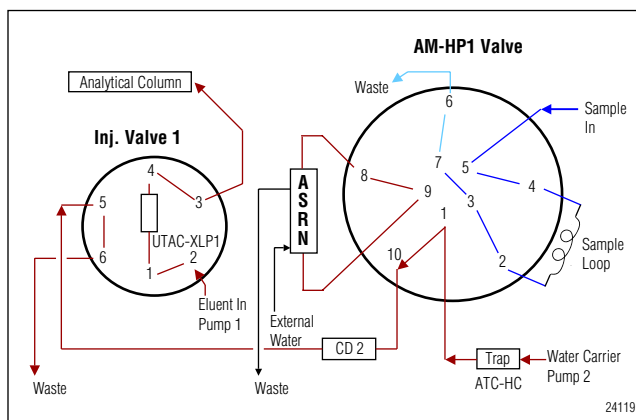

Figure 2. AM-HP1 valve (A) in sample load position.

autosampler loads the sample onto the sample loop, the water carrier by-passes the ASRN II neutralizer and sample loop.

At time zero, the sample is injected as AM-HP1 valve switches to state B (Figure 3) and the water carrier flushes the sample from the sample loop. The valve is switched to state A (Figure 4) at 0.2 min as the sample is carried and trapped in the neutralizer—or “parked” in the neutralizer—where the base is neutralized and the anions are converted to their acid forms. At 8.1 min, Inj. Valve 1 (Figure 5) is switched to Load. At 8.2 min, the AM-HP1 valve is switched to state B, which releases the neutralized sample to the concentrator on System

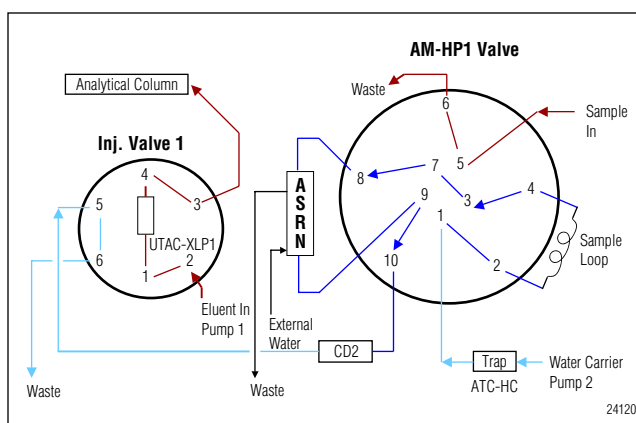

Figure 3. AM-HP1 valve (B) in sample inject position.

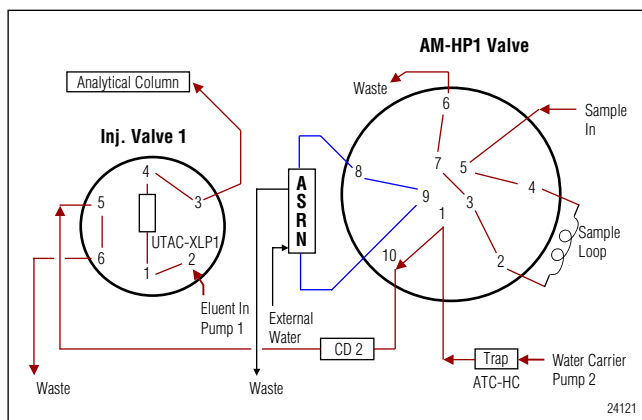

Figure 4. Sample is "Parked and Neutralized."

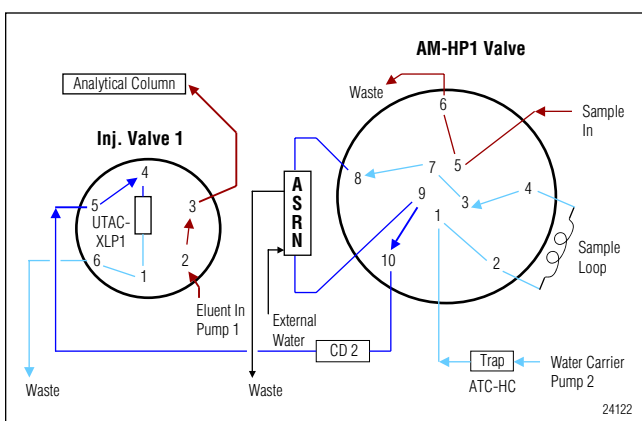

Figure 5. Sample concentrate.

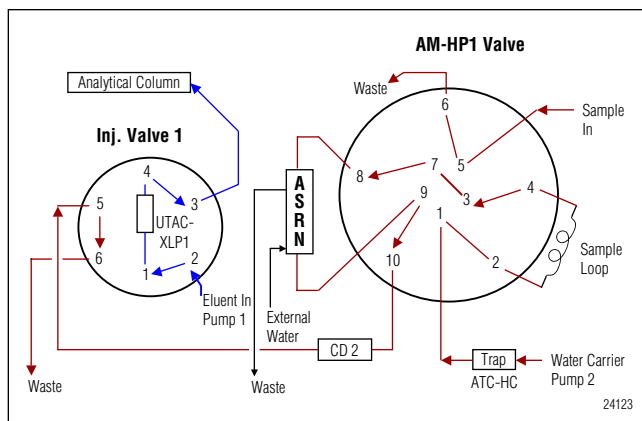

Figure 6. Inject and analyze.

1. After concentrating the anions, the concentrated and neutralized sample is injected (Inj. Valve 1 to Inject at 9.2 min) to the analytical system (Figure 6).

The present study determined the retention times of the eleven anions using 50 µg/L standards of fluoride, chlorite, bromate, nitrite, chlorate, bromide, nitrate, oxalate, and phosphate and 100 µg/L standards of chloride and sulfate. Trace anions in water (Figure 7), 9.9% (w/w) and 29.9% (w/w) sodium hydroxide (Figures 8–9) were determined with this method. The chloride, sulfate, and oxalate concentrations show proportional increases with

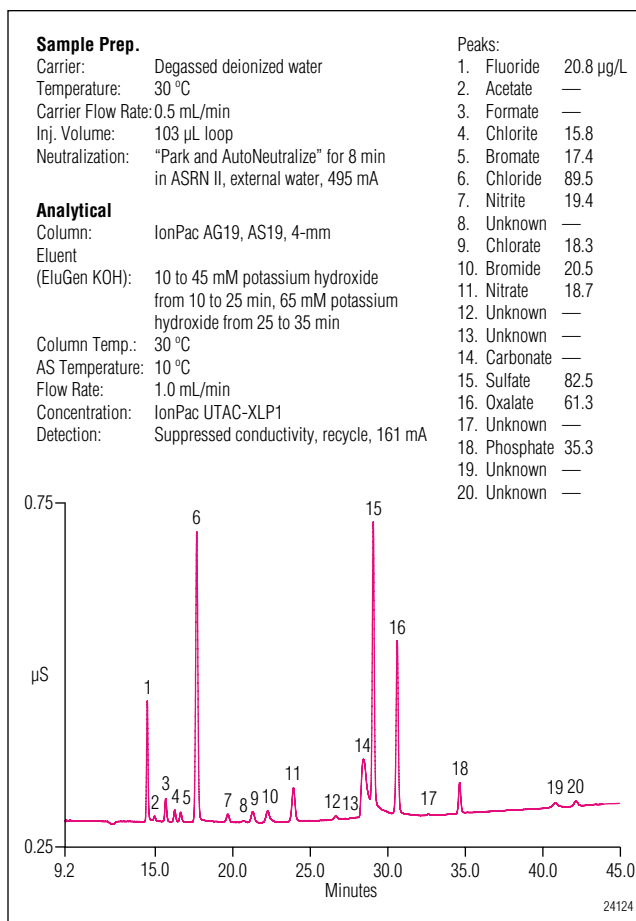

Figure 7. Park and AutoNeutralization of anion standard in water (20 µg/L fluoride, chlorite, bromate, chlorate, bromide, and nitrate, 55 µg/L oxalate, 40 µg/L phosphate, and 100 µg/L chloride and sulfate).

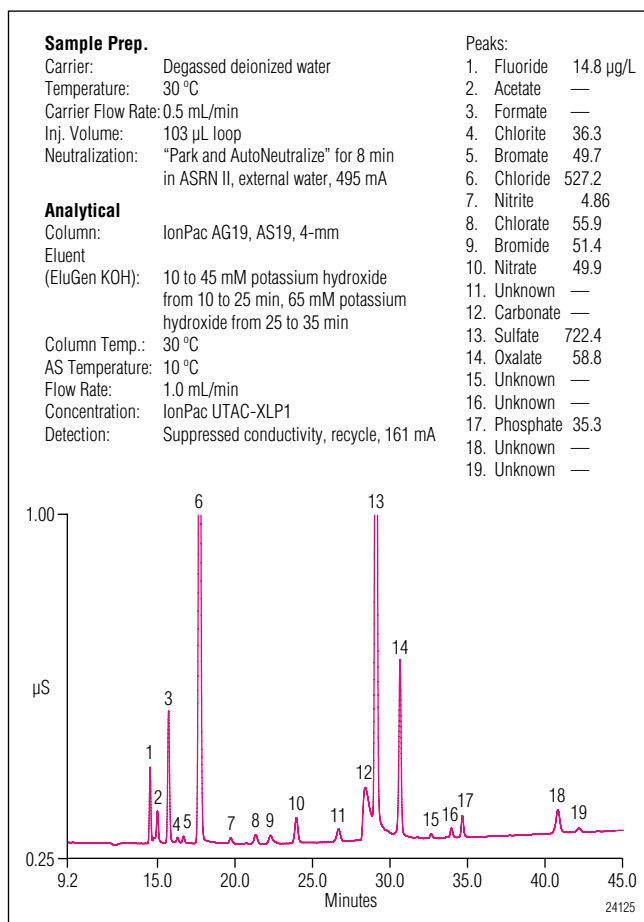

Figure 8. 9.9% (2.5 M) sodium hydroxide spiked with 50 µg/L of fluoride, chlorite, bromate, chlorate, bromide, nitrate, and oxalate, 95 µg/L of phosphate, and 280 µg/L of chloride and sulfate.

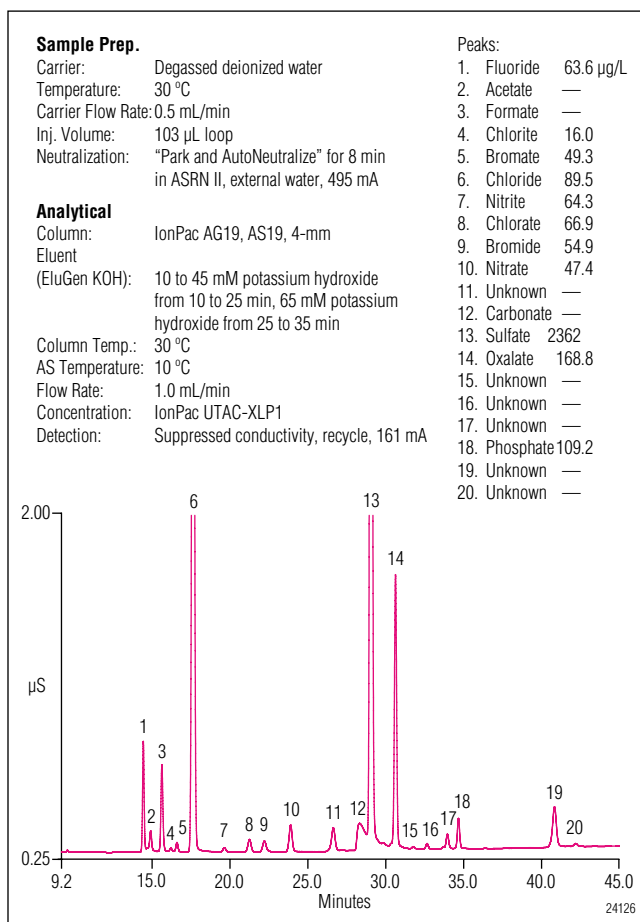

Figure 9. 29.9% (7.5 M) sodium hydroxide spiked with 40 µg/L of fluoride, chlorite, bromate, nitrite, chlorate, bromide, and nitrate, 85 µg/L of oxalate and phosphate, and 430 µg/L of chloride and sulfate.

concentration. This confirms that the timing is correct and that the ASRN II neutralizer has sufficient neutralizing capacity.

In this application the recorded retention times include 9.2 min of sample preparation. To determine reproducibility based on the true retention, we subtracted

the 9.2 min sample preparation time and manually recalculated the RSDs. These retention time reproducibilities of the 10 anions in water, 9.9% and 29.9% sodium hydroxide (Table 5) were good, <1% RSDs. The peak area reproducibilities of the same anions (Table 6) in the same solutions ranged from 0.2 to 2.3% RSDs.

Table 5. Retention Time Reproducibilities of Ten Anions in Water, 9.9% (2.5 M), and 29.9% (7.5 M) Sodium Hydroxide

	Spiked into water			9.9% Sodium Hydroxide with added anions			29.9% Sodium Hydroxide with added anions		
	Amount Present (µg/L)	Retention Time (min) ^a	RSD (%)	Amount Present (µg/L)	Retention Time (min) ^a	RSD (%)	Amount Present (µg/L)	Retention Time (min) ^a	RSD (%)
Fluoride	41.5	5.27	0.6	20.9	5.28	0.5	72.6	5.21	0.8
Chlorite	40.6	7.04	0.5	10.6	7.04	0.4	15.8	7.02	0.5
Bromate	46.4	7.43	0.4	19.7	7.43	0.4	53.4	7.42	0.4
Chloride	359.9	8.46	0.4	389.6	8.46	0.3	1287	8.46	0.4
Chlorate	50.1	12.07	0.3	25.1	12.08	0.2	71.5	12.07	0.3
Bromide	48.8	13.02	0.3	17.2	13.03	0.2	59.4	13.02	0.3
Nitrate	52.1	14.69	0.2	22.2	14.70	0.1	53.6	14.69	0.2
Sulfate	352.9	19.84	<0.1	644.5	19.84	<0.1	2342	19.81	0.1
Oxalate	179.0	21.39	<0.1	93.3	21.39	<0.1	335.0	21.39	<0.1
Phosphate	99.2	25.42	<0.1	40.6	25.42	<0.1	121.5	25.42	<0.1

n=7

^a The sample preparation times (9.2 min) were subtracted from the retention times and the RSDs were re-calculated for the actual retention times.

Table 6. Peak Area Reproducibilities of Ten Anions in Water, 9.9% (2.5 M), and 29.9% (7.5 M) Sodium Hydroxide

	Spiked into water			9.9% Sodium Hydroxide with added anions			29.9% Sodium Hydroxide with added anions		
	Amount Present (µg/L)	Peak Area (µS-min)	RSD (%)	Amount Present (µg/L)	Peak Area (µS-min)	RSD (%)	Amount Present (µg/L)	Peak Area (µS-min)	RSD (%)
Fluoride	41.5	0.036	0.8	20.9	0.020	2.1	72.6	0.061	0.8
Chlorite	40.6	0.006	2.1	10.6	0.002	1.4	15.8	0.002	1.6
Bromate	46.4	0.006	1.5	19.7	0.002	1.9	53.4	0.007	1.7
Chloride	359.9	0.285	0.9	389.6	0.308	0.8	1287	1.017	0.2
Chlorate	50.1	0.011	0.6	25.1	0.006	1.2	71.5	0.016	0.6
Bromide	48.8	0.013	1.1	17.2	0.004	1.6	59.4	0.016	1.2
Nitrate	52.1	0.033	1.8	22.2	0.014	2.3	53.6	0.034	1.3
Sulfate	352.9	0.239	1.2	644.5	0.431	0.5	2342	1.551	0.3
Oxalate	179.0	0.124	1.4	93.3	0.065	1.0	335.0	0.231	0.6
Phosphate	99.2	0.022	1.3	40.6	0.009	2.0	121.5	0.027	0.2

n=7

Method Qualification

The Park and AutoNeutralization method was qualified in water, and 9.9% (w/w) and 29.9% (w/w) sodium hydroxide solutions before determination of trace anions in other concentrated-base samples. The linearity of eleven anions over a four-fold or more concentration range, typical noise, method detection limits (MDLs), reproducibilities, and spike recoveries were determined in water solutions. Spike recovery and 5-day ruggedness were determined in 9.9% and 29.9% sodium hydroxide solutions.

The linearity of peak response for fluoride, chlorite, bromide, and chlorate was measured by determining each anion in five replicates each of seven standards (5, 10, 20, 40, 80, 120, and 200 µg/L). The linearities of peak response for bromate, oxalate, and phosphate were determined from 10–400 µg/L (10, 20, 50, 80, 120, 240, and 400 µg/L). The calibration results showed good linearities over these concentration ranges, $r^2 > 0.999$, (Table 7). Chlorite was the exception and did not show linearity in this range (not shown).

Table 7. Method Detection Limit (MDL) and Linearity

	MDL ^a (µg/L)	RSD	Linearity ^b (r^2)
Fluoride	0.53	5.9	0.9991
Bromate	4.49	4.3	0.9990
Chloride	1.72 ^c	9.5	0.9999
Nitrite	N.A.		0.9991
Chlorate	3.70	8.5	0.9999
Bromide	1.07	2.8	0.9991
Nitrate	0.65	9.0	0.9989
Sulfate	2.25 ^c	4.9	0.9997
Oxalate	1.17 ^c	4.7	0.9992
Phosphate	2.10	3.3	0.9999

n=7

^a MDL is defined as three times the noise.

^b The linearity of fluoride, chlorate, and bromide was determined from 5 to 200 µg/L.

The linearity of bromate, phosphate and oxalate were determined from 10 to 400 µg/L.

The linearity of chloride and sulfate was determined from 100 to 3500 µg/L, the linearity of nitrite and nitrate from 100 to 400 µg/L and 5 to 400 µg/L, respectively.

^c The MDLs of chloride, sulfate, and oxalate are the concentrations in the blank.

The linearity of peak response was measured at higher concentrations for nitrite, nitrate, chloride, and sulfate. The linearities of peak response for chloride and sulfate were measured with triplicate injections of eight standards from 100 to 3500 µg/L (100, 500, 1000, 1500, 2000, 2500, 3000, and 3500 µg/L). The linearity of peak response for nitrate was measured with triplicate injections of nine standards from 5 to 400 µg/L (5, 10, 20, 50, 80, 120, 200, 300, and 400 µg/L). Nitrite was measured in a similar way. The response was not linear at the lower concentrations (<100 µg/L) but it exhibited good linearity ($r^2 > 0.999$) from 100 to 500 µg/L. Nitrate, chloride, and sulfate had good linearity for the full concentration ranges.

The noise was determined over five, 90-min runs, when water was injected, by measuring the noise in 1-min intervals from 45 to 90 min. The noise value determined by this experiment was 1.1 ± 0.4 nS (n=5). The method detection limit (MDL) was defined as three times the noise level, 3.8 ± 1.3 nS. For this application, the MDL concentrations for the eight analytes (except chloride, sulfate, and oxalate) ranged from 0.5 to 4.5 µg/L. The MDL concentrations for chloride, sulfate, and oxalate were set to their baseline concentrations found in the blank, 1.7, 2.3, and 1.2 µg/L, respectively.

Spike recovery was determined for chloride, bromate, chlorate, bromide, nitrate, sulfate, oxalate, and phosphate in 9.9% sodium hydroxide, and 29.9% sodium hydroxide solutions. In the first spike recovery experiments, 47.1 µg/L bromate, chlorate, bromide, nitrate, and oxalate, 282.5 µg/L chloride and sulfate, and 94.1 µg/L phosphate were spiked into 9.9% sodium hydroxide. The recovery was good, 83.3 to 109.2% (Table 8). Similar spike recoveries (97.3–115.1%) were found when spiking 29.9% sodium hydroxide with 43.1 µg/L bromate, chlorate, bromide, and nitrate, 431–434 µg/L chloride and sulfate, and 86.2 µg/L oxalate and phosphate.

Table 8. Recovery of Eight Anions Spiked in 9.9% (2.5 M), and 29.9% (7.5 M) Sodium Hydroxide

	Amount in 9.9% NaOH (µg/L)	Amount Spiked into 9.9% NaOH (µg/L)	Amount Recovered from 9.9% NaOH (%)	RSD	Amount in 29.9% NaOH (µg/L)	Amount Spiked into 29.9% NaOH (µg/L)	Amount Recovered from 29.9% NaOH (%)	RSD
Bromate	N.D.	47.1	99.2	2.2	N.D.	43.1	108.6	1.7
Chloride	278.6	282.5	94.0	0.6	920.4	434	105.0	1.5
Chlorate	5.7	47.1	106.1	0.7	16.1	43.1	113.3	0.6
Bromide	N.D.	47.1	109.2	1.5	4.2	43.1	111.2	1.5
Nitrate	8.1	47.1	90.4	4.2	3.7	43.1	101.7	2.8
Sulfate	532.2	282.5	88.7	0.2	2020	431	97.3	0.7
Oxalate	23.5	47.1	83.3	0.9	86.4	86.2	97.8	1.5
Phosphate	N.D.	94.2	102.7	2.4	N.D.	86.2	115.1	0.5

n=5

N.D. not detected.

We determined the reproducibility and ruggedness of the Park and AutoNeutralization method over 150 injections, about 128 h. During this study we measured four separately prepared solutions each of 9.9% (w/w) and 29.9% (w/w) sodium hydroxide, each spiked with 100 µg/L of chloride and sulfate and 20 µg/L of oxalate. Deionized water injections were inserted between the sample groups. The results (Figures 10–11) show that retention times and peak areas were stable over 128 h of the experiment. The retention time reproducibilities for chloride, sulfate, and oxalate were 8.43 ± 0.02 , 19.87 ± 0.04 , and 21.32 ± 0.04 min, respectively. Notice that the sample preparation times were subtracted for reproducibility determinations. The peak areas were reproducible and stable (0.37 ± 0.01 , 0.31 ± 0.01 , and 0.03 ± 0.00 µS-min, for chloride, sulfate, and oxalate, respectively).

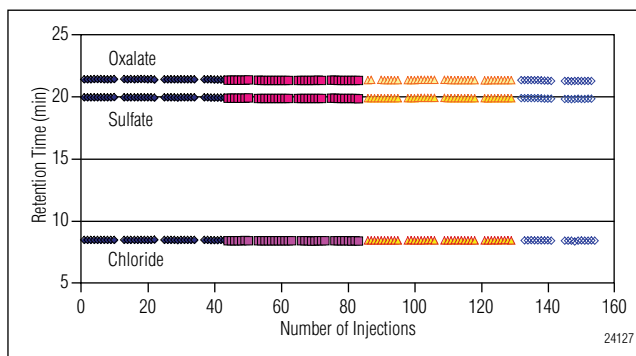

Figure 10. Retention time stability of chloride, sulfate, and oxalate over 5 days. 100 µg/L of chloride and sulfate, and 20 µg/L of oxalate spiked into 10% sodium hydroxide.

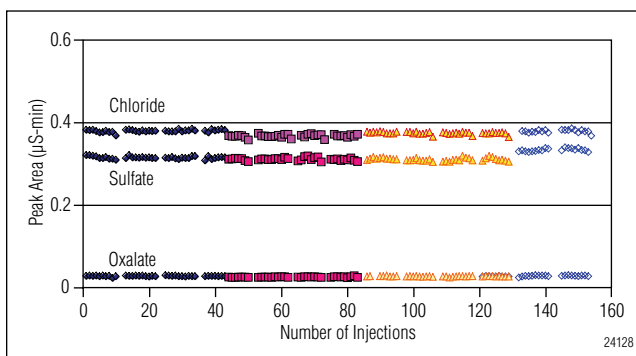

Figure 11. Peak area stability of chloride, sulfate, and oxalate over 5 days, 100 µg/L of chloride and sulfate, and 20 µg/L of oxalate spiked into 10% sodium hydroxide.

Chloride, sulfate, and oxalate also had stable retention times in 29.9% sodium hydroxide: 8.48 ± 0.02 , 19.85 ± 0.03 , and 21.40 ± 0.03 min, respectively (Figures 12–13). The peak areas for chloride, sulfate, and oxalate were approximately three times those for the 9.9% sodium hydroxide solutions: 1.05 ± 0.03 , 1.58 ± 0.06 , and 0.07 ± 0.00 $\mu\text{S}\cdot\text{min}$, respectively. These experiments showed that the ASRN II neutralizer neutralized the 30% sodium hydroxide solutions in 8 min.

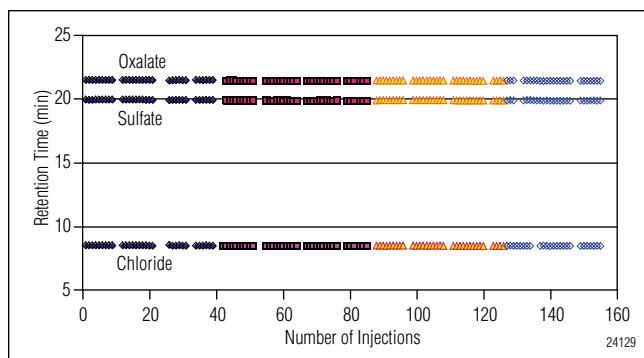

Figure 12. Retention time stability of chloride, sulfate, and oxalate over 5 days, 100 $\mu\text{g/L}$ of chloride and sulfate and 20 $\mu\text{g/L}$ of oxalate spiked into 30% sodium hydroxide.

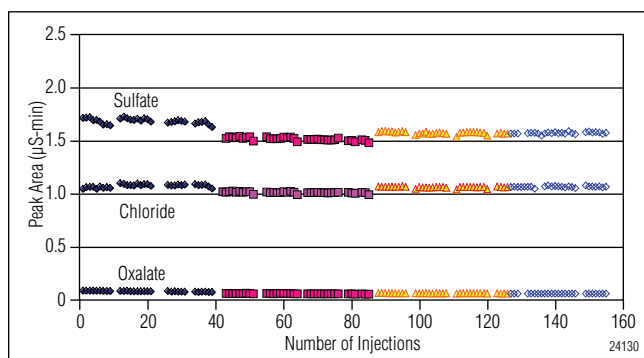

Figure 13. Peak area stability of chloride, sulfate, and oxalate over 5 days, 100 $\mu\text{g/L}$ of chloride and sulfate, and 20 $\mu\text{g/L}$ of oxalate spiked into 30% sodium hydroxide.

Determination of Trace Anions in 29.9% Potassium Hydroxide and Concentrated (59.7%) Ammonium Hydroxide

We applied the Park and AutoNeutralization method to determine trace anions in 29.9% potassium hydroxide and 59.7% (concentrated) ammonium hydroxide. Spike recovery of selected anions and background sulfate concentrations were determined for both solutions. The 29.9% potassium hydroxide solution had low concentrations of chlorate (24.1 ± 0.19 $\mu\text{g/L}$), moderate concentrations of oxalate (108.9 ± 1.4 $\mu\text{g/L}$), and high concentrations of sulfate (427.1 ± 4.8 $\mu\text{g/L}$) and chloride (3058 ± 24 $\mu\text{g/L}$) (Figure 14). Spike recoveries of 49.6 $\mu\text{g/L}$ bromate, chlorate, bromide, and nitrate, and 79.3 $\mu\text{g/L}$ oxalate, 99.2 $\mu\text{g/L}$ phosphate, 208 $\mu\text{g/L}$ chloride, and 496 $\mu\text{g/L}$ sulfate were good, at 91.2–109.3% (Table 9).

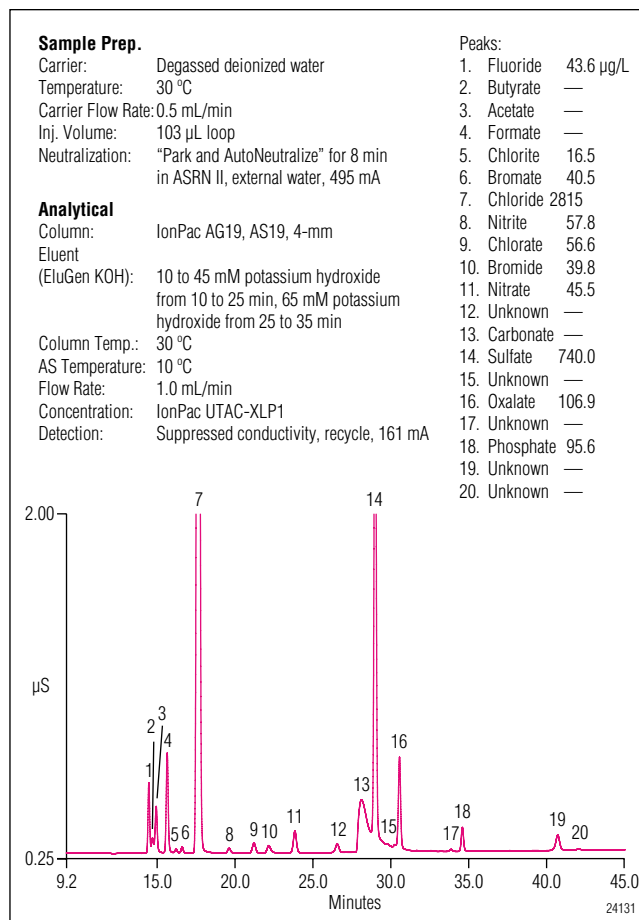

Figure 14. 29.9% potassium hydroxide spiked with 50 $\mu\text{g/L}$ of fluoride, chlorite, bromate, nitrite, chlorate, bromide, and nitrate, 80 $\mu\text{g/L}$ of oxalate, 100 $\mu\text{g/L}$ of phosphate, 210 $\mu\text{g/L}$ of chloride, and 500 $\mu\text{g/L}$ of sulfate.

Table 9. Recovery of Eight Anions Spiked in 29.9% (5.4 M) Potassium Hydroxide

	Amount in 29.9% KOH (µg/L)	RSD	Amount Added (µg/L)	Amount Recovered (%)	RSD
Bromate	N.D.		49.6	101.6	1.7
Chloride	3058	0.8	208	96.7	1.6
Chlorate	24.1	0.8	49.6	92.7	3.4
Bromide	N.D.		49.6	100.4	1.2
Nitrate	N.D.		49.6	91.7	3.4
Sulfate	427.1	1.1	496	95.7	2.2
Oxalate	108.9	1.3	79.3	91.2	2.0
Phosphate	N.D.		99.2	109.3	2.5

n=5

N.D. not detected.

The concentrated (59.7%, 15.2 M) ammonium hydroxide solution (Figure 15) had low concentrations of chlorite, oxalate, and bromide (<25 µg/L), moderate concentrations of chloride (109.5 ± 2.1 µg/L) and nitrate (85.4 ± 2.2 µg/L), and high concentrations of nitrite (191.4 ± 4.3 µg/L), and sulfate (227.0 ± 1.9 µg/L). Spike recoveries of 43.8 µg/L bromide, 85.0 µg/L nitrate, 200.8–218.8 µg/L of chloride, nitrite, and sulfate, and 85.0 µg/L oxalate were good, at 95.5 to 107.0% (Table 10).

Table 10. Recovery of Six Anions Spiked in 59.7% (15.2 M) Ammonium Hydroxide

	Amount in Concentrated NH ₄ OH (µg/L)	RSD	Amount Added (µg/L)	Amount Recovered (%)	RSD
Chloride	109.5	1.9	200.8	95.5	0.4
Nitrite	191.4	6.0	218.8	107.0	3.8
Bromide	N.D.		43.8	100.3	1.6
Nitrate	85.4	2.5	85.0	96.9	2.2
Sulfate	227.0	0.9	218.8	99.5	0.6
Oxalate	24.9	5.9	95.0	100.9	0.3

n=5

N.D. not detected.

Sample Prep.
 Carrier: Degassed deionized water
 Temperature: 30 °C
 Carrier Flow Rate: 0.5 mL/min
 Inj. Volume: 103 µL loop
 Neutralization: "Park and AutoNeutralize" for 8 min in ASRN II, external water, 495 mA

Analytical
 Column: IonPac AG19, AS19, 4-mm
 Eluent (EluGen KOH): 10 to 45 mM potassium hydroxide from 10 to 25 min, 65 mM potassium hydroxide from 25 to 35 min
 Column Temp.: 30 °C
 AS Temperature: 10 °C
 Flow Rate: 1.0 mL/min
 Concentration: IonPac UTAC-XLP1
 Detection: Suppressed conductivity, recycle, 161 mA

Peaks:
 1. Fluoride 82.4 µg/L
 2. Butyrate —
 3. Acetate —
 4. Formate —
 5. Chloride 109.5
 6. Nitrite 191.4
 7. Bromide 8.0
 8. Nitrate 85.4
 9. Unknown —
 10. Carbonate —
 11. Sulfate 227.0
 12. Oxalate 24.9
 13. Unknown —
 14. Unknown —
 15. Phosphate 4.2
 16. Unknown —
 17. Unknown —
 18. Unknown —

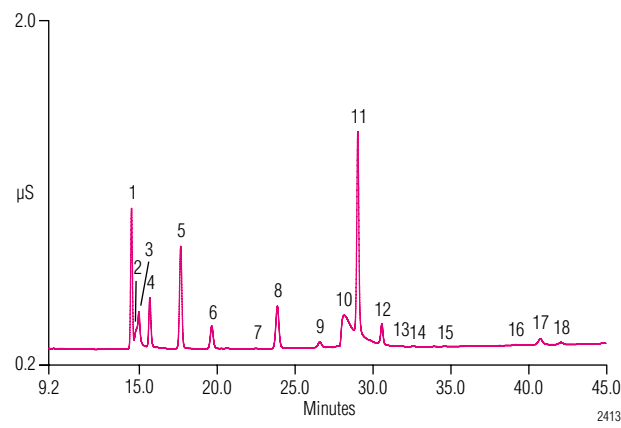

Figure 15. Concentrated (59.7% as NH₄OH, 15.2 M) ammonium hydroxide.

CONCLUSION

Using the Automation Manager, the dual pump, dual detectors, and eluent generation of an ICS-3000, this application note demonstrates that strong bases can be neutralized to allow determination of µg/L anion concentrations. The neutralization occurs automatically within the temperature-controlled environment of the ICS-3000 DC using the ASRN II neutralizer. The setup described here is an easy, automated, and reproducible method to determine µg/L anion concentrations in strong bases.

Although not discussed in this application note, trace concentrations of cations can also be determined in concentrated acids using the same techniques and the corresponding cation components.

PRECAUTIONS

Always handle concentrated bases with extreme caution. Consult the Material Safety Data Sheets (MSDS) for protective clothing, storage, disposal, and health effects. Use only low pressure concentrator columns, such as the IonPac UTAC-XLPI, with the ASRN II neutralizer. Pressures >100 psi can cause irreversible damage. Always verify that the external water regenerant is flowing through the neutralizer before applying current and turn it off when the pump is off. In this application, baseline sulfate levels should be determined for your samples because sulfate from the neutralizer can be extracted by the sample during the neutralization process. Fluoride and chlorite can not be determined quantitatively with this method. Nitrite was not stable at low $\mu\text{g/L}$ concentrations and therefore quantitative determinations are not recommended below 100 $\mu\text{g/L}$. Always use high-quality deionized water (>18 M-ohm) for preparing reagents and samples.

Do not over-tighten the fittings on the Carbonate Removal Device (CRD): tighten to finger-tight.

REFERENCES

1. Preparing Vegetables, Home of Australia's Favorite Food Brands.htm, Simplot Australia Pty Ltd, 2006.
2. Determination of Trace Anions in Concentrated Bases Using AutoNeutralization Pretreatment/Ion Chromatography. Application Note 93; LPN 0545. Dionex Corporation, Sunnyvale, CA, 1994.
3. Determination of Trace Anions in Concentrated Bases Using AutoNeutralization Pretreatment/Ion Chromatography. Application Note 93; LPN 1633-01. Dionex Corporation, Sunnyvale, CA, 2004.
4. Determination of Trace Cations in Concentrated Acids Using AutoNeutralization Pretreatment / Ion Chromatography. Application Note 94; LPN 1666. Dionex Corporation, Sunnyvale, CA, 2004.
5. Srinivasan, K.; Lin, R.; Avdalovic, N.; Pohl, C.; A New Neutralizer Method for Analysis of Trace Anions in Bases and Trace Cations in Acids; LPN 1659. Poster presented at the 17th Annual International Ion Chromatography Symposium (IICS), Trier, Germany, September 20-23, 2004.
6. Reducing Carbonate Interference in Anion Determinations with the Carbonate Removal Device (CRD). Technical Note 62; LPN 1765. Dionex Corporation, Sunnyvale, CA, 2006.
7. Determination of Trace Anions in High Purity Waters by High-Volume Direct Injection with the EG40. Application Update 142; LPN 1290. Dionex Corporation, Sunnyvale, CA, 2001.
8. Product Manual for Anion Self-Regenerating Neutralizer ASRN II and Cation Self-Regenerating Neutralizer CSRN II. LPN 034962. Dionex Corporation, Sunnyvale, CA, 1998.
9. Operator's Manual for ICS-3000 Ion Chromatography System; LPN 065031. Dionex Corporation, Sunnyvale, CA, 2005.
10. Installation Instructions for ICS-3000 Ion Chromatography System; LPN 065032. Dionex Corporation, Sunnyvale, CA, 2005.
11. Product Manual for IonPac Anion Trap Column ATC-HC; LPN 032697. Dionex Corporation, Sunnyvale, CA, 2002.
12. Product Manual for Anion Self-Regenerating Neutralizer ASRN II and Cation Self-Regenerating Neutralizer CSRN II: QuickStart; LPN 034963. Dionex Corporation, Sunnyvale, CA, 1998.
13. Operator's Manual for AS Autosampler; LPN 065051. Dionex Corporation, Sunnyvale, CA, 2005.
14. Operator's Manual for ICS-3000 Ion Chromatography System; LPN 065031. Installing a New EGC Cartridge, Installing a New CR-ATC, and Installing a Backpressure Coil, Sections 9.12.3–9.12.4, 9.13.3–9.13.5, and 9.15, P. 210–217, P. 219–222 and P. 224. Dionex Corporation, Sunnyvale, CA, 2005.
15. Product Manual for IonPac UTAC; LPN 065091. Dionex Corporation, Sunnyvale, CA, 2005.
16. Product Manual for IonPac AG19 Guard and AS19 Analytical Columns; LPN 065003. Dionex Corporation, Sunnyvale, CA, 2005.
17. Product Manual for Anion Self-Regenerating Suppressor ULTRA II and Cation Self-Regenerating Suppressor ULTRA II; LPN 031956. Dionex Corporation, Sunnyvale, CA, 2004.
18. Product Manual for Carbonate Removal Device; LPN 065068. Dionex Corporation, Sunnyvale, CA, 2005.

SUPPLIERS

Fisher Scientific International Inc., Liberty Lane,
Hampton, NH 03842 USA, 1-800-766-7000,
www.fisherscientific.com

VWR International, Inc., Goshen Corporate Park West,
1310 Goshen Parkway, West Chester, PA 19380
USA, 1-800-932-5000, www.vwrsp.com

Sigma-Aldrich, Inc., P.O. Box 951524,
Dallas, TX 75395-1524 USA, 1-800-325-3010,
www.sigmaaldrich.com

Teflon is a registered trademark of E.I. du Pont de Nemours. PEEK is a trademark of Victrex PLC. Reagent-Plus is a registered trademark of Sigma-Aldrich Biotechnology LP. All other trademarks or registered trademarks are property of Dionex Corporation.

Passion. Power. Productivity.



Dionex Corporation

1228 Titan Way
P.O. Box 3603
Sunnyvale, CA
94088-3603
(408) 737-0700

North America

U.S. (847) 295-7500
Canada (905) 844-9650

South America

Brazil (55) 11 3731 5140

Europe

Austria (43) 1 616 51 25 Benelux (31) 20 683 9768 (32) 3 353 4294
Denmark (45) 36 36 90 90 France (33) 1 39 30 01 10 Germany (49) 6126 991 0
Ireland (353) 1 644 0064 Italy (39) 02 51 62 1267 Switzerland (41) 62 205 9966
United Kingdom (44) 1276 691722

Asia Pacific

Australia (61) 2 9420 5233 China (852) 2428 3282 India (91) 22 27642735
Japan (81) 6 6885 1213 Korea (82) 2 2653 2580 Singapore (65) 6289 1190

www.dionex.com



LPN 1886 05/07
©2007 Dionex Corporation