

# Determination of Sugar Alcohols in Confections and Fruit Juices by High-Performance Anion-Exchange Chromatography with Pulsed Amperometric Detection

## INTRODUCTION

Sugar alcohols are used in confectionary products because they impart a sweet taste without the calories associated with sugars. Sorbitol (60% as sweet as sucrose)<sup>1</sup> and mannitol are sugar alcohols commonly used as replacements for sucrose in dietetic candy. However, their use in foods is regulated because they exhibit laxative and diuretic properties.

Sugar alcohols, also called alditols, are the reduced forms of monosaccharide aldoses. For example, *D*-glucose can be reduced to glucitol (sorbitol).<sup>2</sup> See Figure 1.

The CarboPac™ MA1 has unique selectivity for sugar alcohols. As a high-performance, high-capacity anion exchange column, the CarboPac MA1 permits sugar alcohols to be resolved at elevated sodium hydroxide concentrations. Unlike metal-loaded columns (often used for sugar alcohol analysis), the CarboPac MA1 operates at ambient temperature and employs sodium hydroxide eluent for high pH separations and maximum sensitivity using pulsed amperometric detection (PAD). Also unlike metal-loaded columns, which elute large saccharides first and sugar alcohols last, the elution order using the CarboPac MA1 column is determined by  $pK_a$  values. The sugar alcohols with higher  $pK_a$  values elute first, then monosaccharides and disaccharides that have lower  $pK_a$ s (see Figure 2).

Carbohydrates (e.g., alditols and aldoses) are weak acids that ionize at pH 12 to 14. At these pH levels, carbohydrates can be separated by anion-exchange mechanisms. Sugar alcohols have higher  $pK_a$  values than mono- and disaccharides, thus higher pH eluents are required to separate them from one another by anion exchange. The CarboPac MA1 column uses a higher concentration of sodium hydroxide (typically up to 600 mM) for its eluent than the other CarboPac columns.

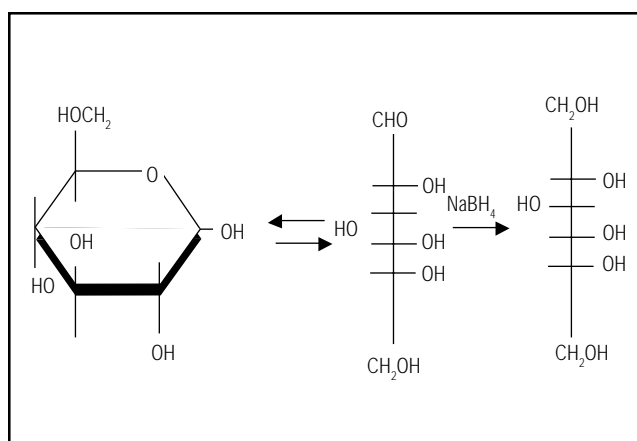

**Figure 1** *D*-Glucose reduced to glucitol (sorbitol).

This application note focuses on sugar alcohols found in confections and fruit juices. However, the CarboPac MA1 is also useful for sugars found in physiological fluids, living tissues, and for reduced carbohydrate moieties of glyco-conjugates (e.g.,  $\beta$ -elimination reaction products).

## EQUIPMENT

Dionex chromatography system consisting of:  
Gradient Pump

Liquid Chromatography Module

Pulsed Electrochemical Detector

Dionex PeakNet or AI-450 Chromatography Workstation

## REAGENTS AND STANDARDS

18 M $\Omega$ -cm Deionized water

Sodium hydroxide solution, 50% (w/w), low carbonate

Standards consisting of: Inositol, Xylitol, Sorbitol, Mannitol, Glucose, Fructose, Sucrose, Dulcitol, Arabinose, Mannose, Xylose, and Galactose

## CONDITIONS

Column: CarboPac MA1 (4 x 250 mm)  
Expected Operating Pressure: 5.5 to 7.6 MPa (800 to 1100 psi)  
Injection Volume: 10  $\mu$ L  
Eluents: A: Deionized water  
B: 1.0 M Sodium hydroxide  
Flow Rate: 0.4 mL/min  
Detection: Pulsed amperometry, gold working electrode

ED40 Settings as follows\*:

t (ms)	E (volts)	Integration (s)
400	+0.05	0.2–0.4
200	+0.75	
400	-0.15	

\*See Technical Note 21 for a discussion of pulse potentials, including settings to use with a PAD.<sup>3</sup>

## PREPARATION OF REAGENTS AND STANDARDS

### Eluent A: Deionized Water

Vacuum degas 1 L of 18 M $\Omega$ -cm deionized water.

### Eluent B: 1 M Sodium Hydroxide

Dilute 52 mL of sodium hydroxide solution in 1.0 L of degassed 18 M $\Omega$ -cm deionized water. Use a sodium hydroxide solution that is 50% (w/w) and contains low carbonate. Sodium hydroxide pellets are coated with a layer of carbonate and will not produce acceptable eluents.

## SAMPLE PREPARATIONS

### "Sugarless" Hard Candy

Dissolve one candy drop (weighing 3.4 g) in 10 mL of deionized water and dilute 1:1000 with 18 M $\Omega$ -cm deionized water.

### Apple Juice

Dilute apple juice 1:1000 with 18 M $\Omega$ -cm deionized water.

### Chewing gum extract

Divide one stick of chewing gum (weighing 2.7 g) into small pieces (of approximately 3 x 3 mm), and sonicate gum in 10 mL of deionized water for 10 minutes. Then pass the supernatant through an OnGuard A (prepare by passing 5 mL of deionized water through the cartridge at a flow rate of 2-mL/min; discard the first 3 mL of the sample), to remove anions and pass it through a 0.45- $\mu$ m filter to remove particulates. Dilute the filtrate 1:1000 with 18 M $\Omega$ -cm deionized water.

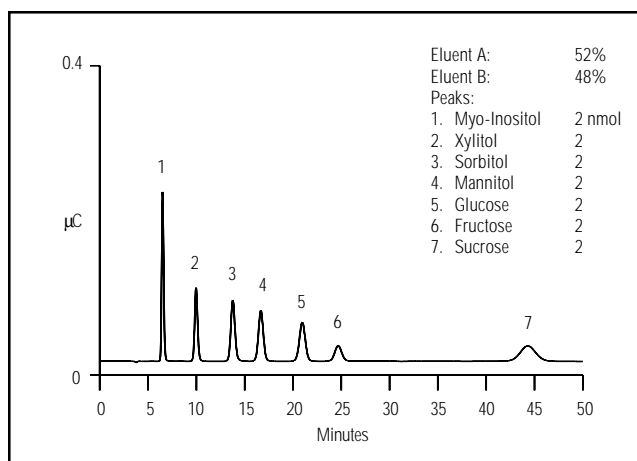

Figure 2 Sugar alcohols with high  $pK_a$  values elute first.

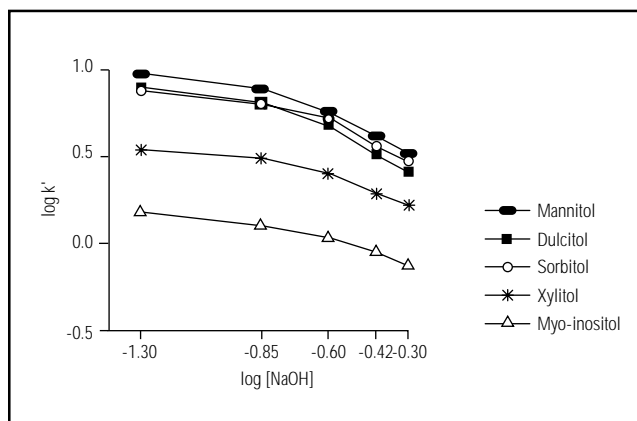

Figure 3A Log capacity factor vs. log sodium hydroxide concentration of some sugar alcohols.

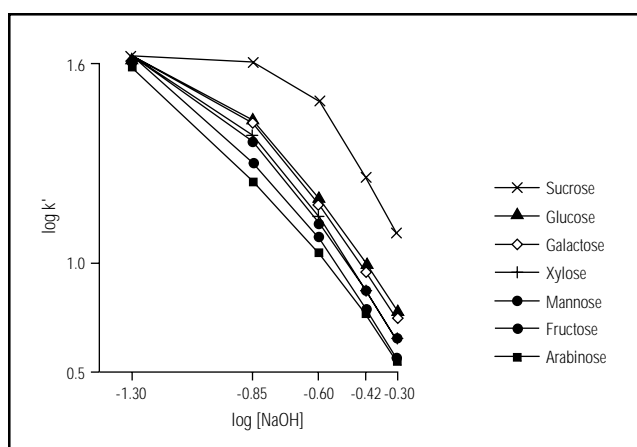

Figure 3B Log capacity vs. log sodium hydroxide concentration of selected carbohydrates.

## DISCUSSION AND RESULTS

The CarboPac MA1 allows 0 to 1 M sodium hydroxide eluent concentrations. This is important for the separation of sugar alcohols because their  $pK_a$ s are high and each is unique. Separation on the CarboPac MA1 can be achieved by choosing an eluent pH near the  $pK_a$  value of a sugar alcohol. Altering an eluent's pH by varying the sodium hydroxide concentration changes the effective charge on the compounds. This in turn can change the elution order so that those sugar alcohols of interest will be resolved from one another. Figures 3A and 3B show capacity factors vs. eluent concentration for some common sugar alcohols. It is possible to predict which eluent strength will work best for a particular separation.

Figure 4 shows a chromatogram of "sugarless" hard candy. This particular candy is sold as dietetic candy. Its major PAD-active, water-soluble components are sorbitol and mannitol. The 3.4-g candy drop contained 2.70 g of sorbitol and 50.5 mg of mannitol.

Figure 5 shows a chromatogram of diluted apple juice. Glucose, fructose, and sucrose are found in all fruit juices. Sorbitol is found in apples, pears, and plums, among other fruits.<sup>4</sup> An 8-ounce (237-mL) serving of this apple juice contains 1.86 g of sorbitol, 8.22 g of glucose, 18.8 g of fructose, and 7.76 g of sucrose.

Figure 6 shows a chromatogram of chewing gum extract. The peaks are glycerol, sorbitol, mannitol, and hydrogenated glucose syrup, respectively. The 2.7-g stick of chewing gum contains 218 mg of glycerol, 1140 mg of sorbitol, and 280 mg of mannitol. Hydrogenated glucose syrup was not quantitated.

Operators of refractive index (RI) detection may notice the low detection limits presented in Table 1. Pulsed amperometric detection (PAD) is routinely able to achieve these low levels. Pulsed amperometric detectors apply a potential at an electrode to oxidize the carbohydrate. This not only allows for low detection limits, but also increases specificity and freedom from matrix interferences.

PAD utilizes a repeating sequence of three potentials. The durations of these three potentials are optimized for carbohydrates. If a single potential is used, the peak heights will steadily decrease as the electrode surface fouls. For further details concerning pulsed sequences for PAD, refer to Dionex Technical Note 21.<sup>3</sup>

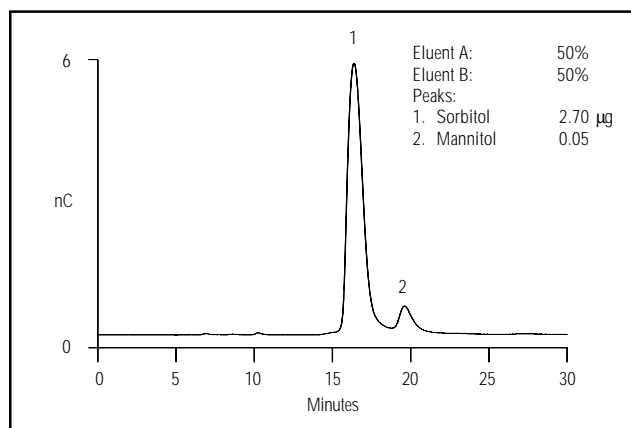

**Figure 4** "Sugarless" hard candy containing sorbitol and mannitol.

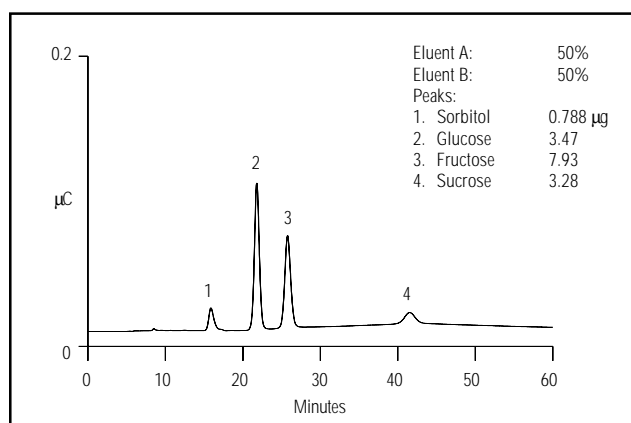

**Figure 5** Diluted apple juice containing sorbitol.

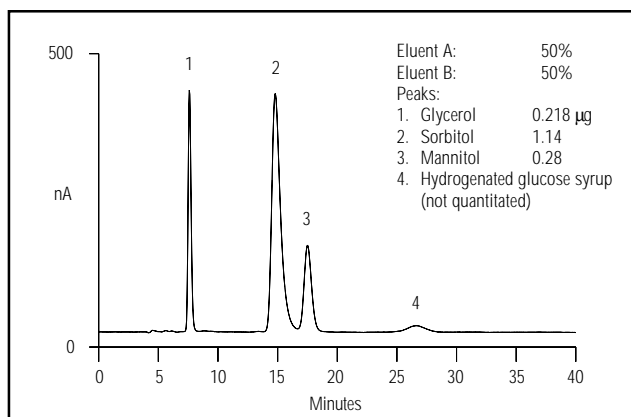

**Figure 6** Chewing gum extract containing glycerol, sorbitol, and mannitol.

To drive the oxidation reaction at the working electrode of the pulsed amperometric detector, the eluent must be greater than pH 12. Dionex CarboPac columns are designed using a polymer-base for stability and durability in the 0 to 14 pH range. For further details concerning carbohydrate determination with PAD, refer to Dionex Technical Note 20.<sup>5</sup>

### CONCLUSION

The Dionex CarboPac MA1 is the preferred column for the analysis of sugar alcohols. It yields excellent resolution and allows for changes in carbohydrate selectivity; the column permits changes in the eluent concentration and hence pH levels. The CarboPac MA1 is used for pulsed amperometric detection of sugar alcohols with high sensitivity and specificity without derivatization or the addition of a postcolumn reagent. This column operates at ambient temperatures to promote ease-of-use and an increased lifetime. As with other CarboPac columns, the MA1 demonstrates long-term reproducibility and durability.

### PRECAUTIONS

The CarboPac MA1 has an operational flow rate range of 0.2–0.5 mL/min. The maximum flow rate possible without irreversible compression of the column resin is 0.8 mL/min. The maximum pressure that the column can withstand without irreversible compression of the macroporous resin is 13.8 MPa (2000 psi).

Metal should be eliminated from the flow path prior to column use. If an autosampler is used, all flow paths should be metal-free. Metal contamination of the analytical column can result in poor peak efficiency and/or symmetry, which may lead to poor reproducibility.

If a PED is used, the Ag/AgCl reference electrode is preferred over the combination pH-Ag/AgCl reference electrode. Sodium hydroxide eluents above 200 mM will cause the delicate glass bulb of the electrode to become brittle and break.

**Table 1 Detection limits and linearity data for the carbohydrates in Figure 1**

Standard	r <sup>2</sup> <sup>a</sup>	Method Detection Limit (pmol) <sup>b</sup>
myo-inositol	0.9995	2
xylitol	0.9953	4
sorbitol	0.9951	5
mannitol	0.9995	4
glucose	0.9984	10
fructose	0.9995	10
sucrose	0.9999	10

<sup>a</sup> The coefficients of determination were calculated over the range of 10 to 30,000 picomoles or 3 orders of magnitude.

<sup>b</sup> The method detection limits of myo-inositol, xylitol, sorbitol, and mannitol were determined at three times the noise.

### REFERENCES

1. Shaw, P.E. *CRC Handbook of Sugar Separations in Foods by HPLC*; CRC Press, Boca Raton, Florida, 1988.
2. Solomons, T.W.G. *Organic Chemistry*, 2nd ed., John Wiley & Sons, New York, 1980.
3. Dionex, Technical Note 21: "Optimal Settings for Pulsed Amperometric Detection of Carbohydrates using the Dionex Pulsed Electrochemical Detector (PED-2) and the Pulsed Amperometric Detector (PAD-2)".
4. Coppola, E.D. *Food Technology*. **1984**, 38(4), 88-91.
5. Dionex, Technical Note 20: "Analysis of Carbohydrates by Anion Exchange Chromatography with Pulsed Amperometric Detection".

CarboPac is a trademark of Dionex Corporation.

 Printed on recycled and recyclable paper using soy-based inks.

**Dionex Corporation**  
1228 Titan Way  
P.O. Box 3603  
Sunnyvale, CA  
94088-3603  
(408) 737-0700

**Dionex Corporation**  
Salt Lake City Technical Center  
1515 West 2200 South, Suite A  
Salt Lake City, UT  
84119-1484  
(801) 972-9292

**Dionex U.S. Regional Offices**  
Sunnyvale, CA (408) 737-8522  
Westmont, IL (630) 789-3660  
Houston, TX (281) 847-5652  
Smyrna, GA (770) 432-8100  
Marlton, NJ (609) 596-0600

**Dionex International Subsidiaries**  
Austria (0222) 616 51 25 Belgium (015) 203800 Canada (905) 844-9650 France 01 39 46 08 40 Germany (06126) 991-0  
Italy (6) 66030052 Japan (06) 885-1213 The Netherlands (076) 57 14 800 Switzerland (062) 205 99 66 United Kingdom (01276) 691722  
\* Designed, developed, and manufactured under an NSAI registered ISO 9001 Quality System.  
<http://www.dionex.com>



LPN 0534-02 1M 8/97  
© 1997 Dionex Corporation